

# BROGRUND

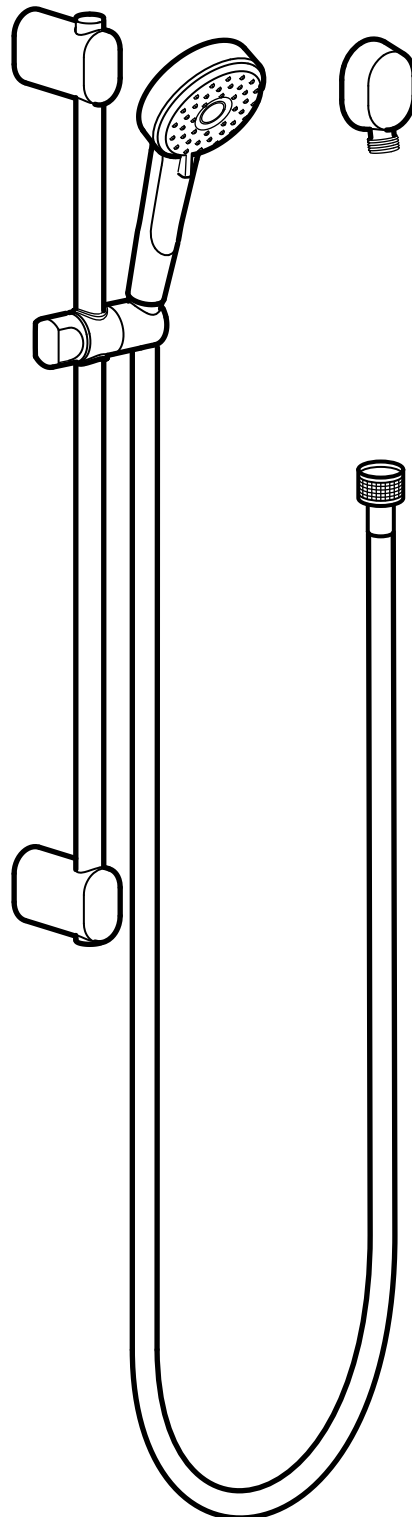

Design and Quality  
IKEA of Sweden

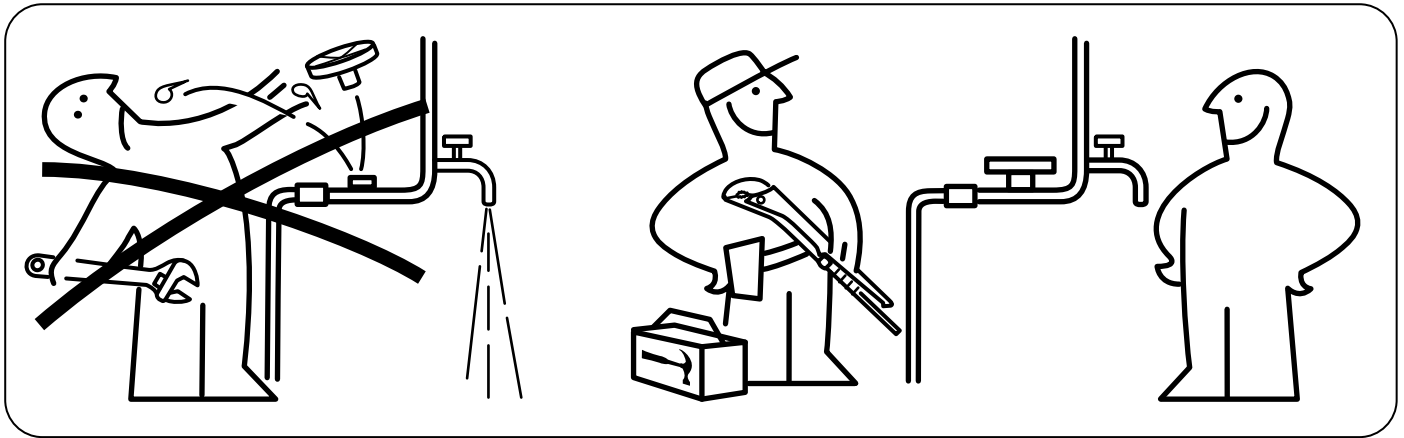

**ENGLISH**

Installation must be performed in compliance with current local construction and plumbing regulations. If in doubt, contact a professional.

**FRANÇAIS**

L'installation doit être réalisée en conformité avec les normes actuelles relatives à la construction et à la plomberie. En cas de doute, contacter un professionnel.

**ESPAÑOL**

La instalación debe realizarse siguiendo las normativas actuales sobre construcción y fontanería. En caso de duda, ponte en contacto con un profesional.



**ENGLISH**

Switch off main shut-off valve before changing mixer tap.

**FRANÇAIS**

Fermer le robinet central d'eau avant de changer le mitigeur.

**ESPAÑOL**

Cierra la llave de paso general antes de cambiar el grifo.

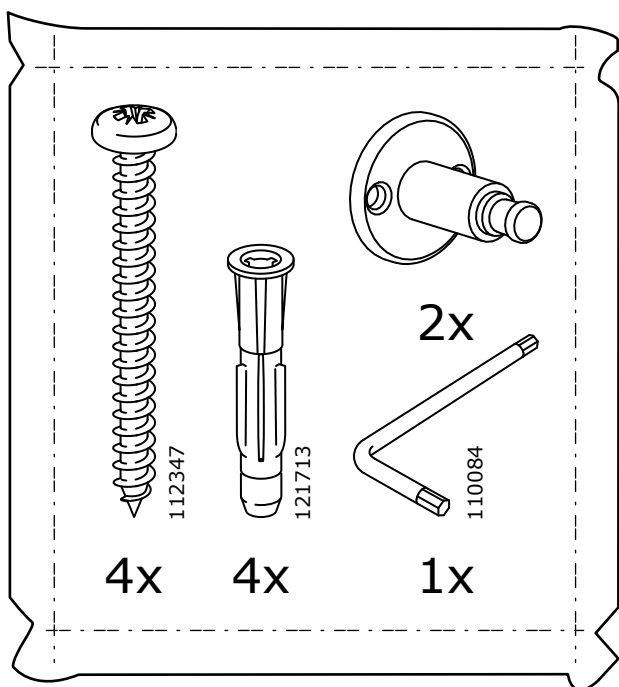
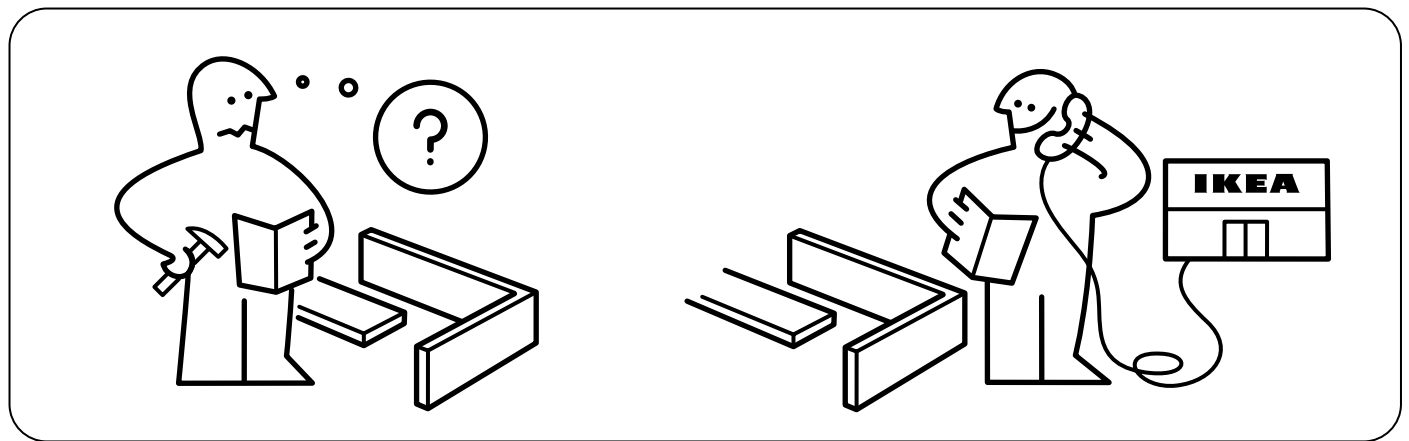
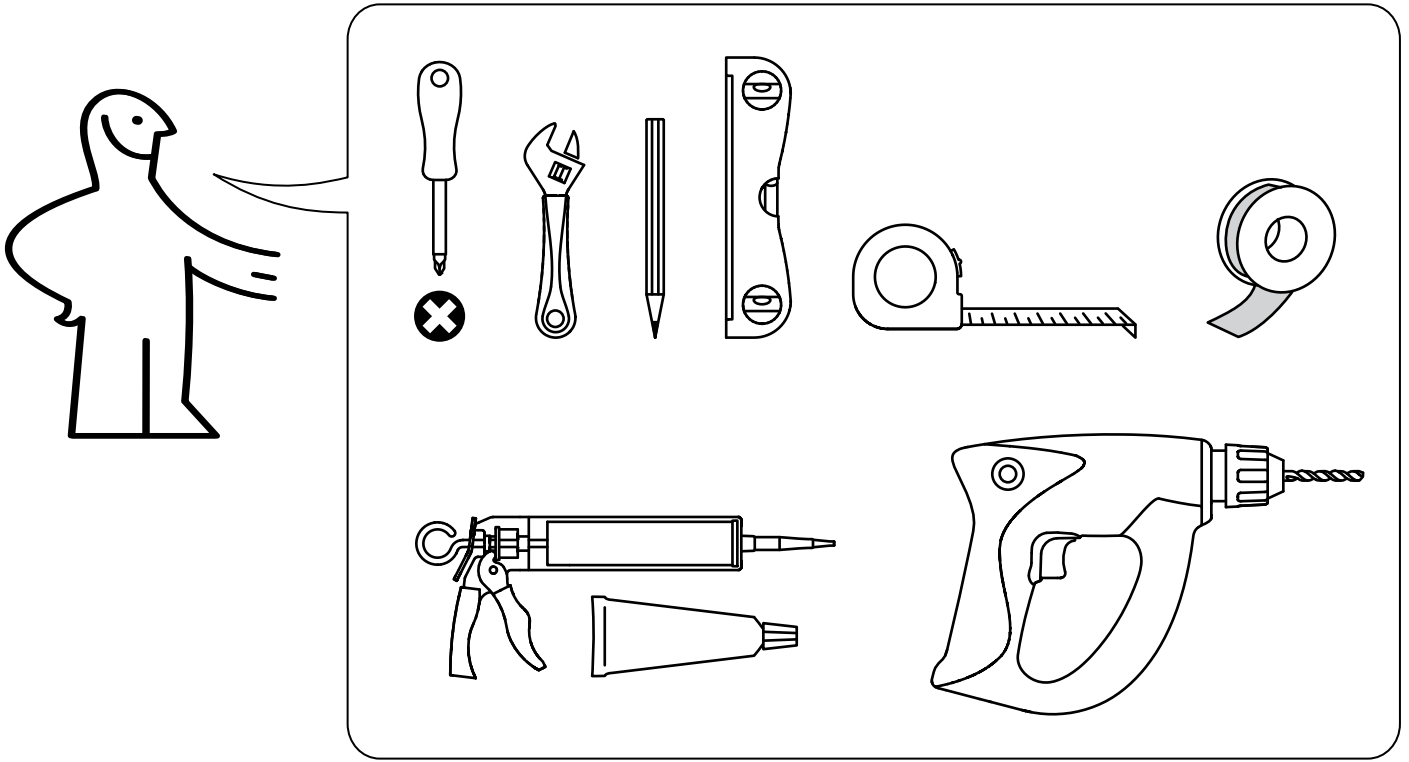

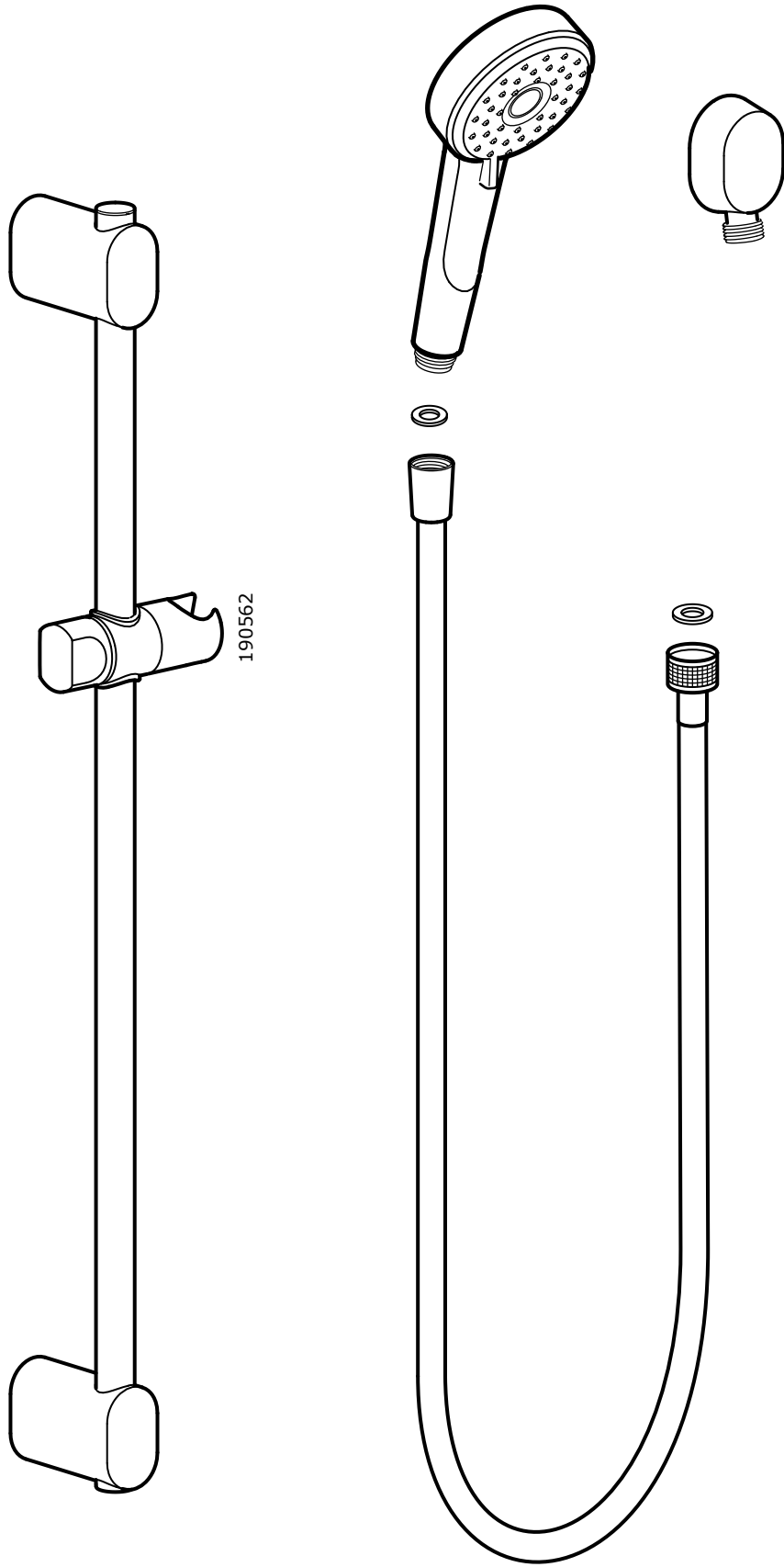

# 1

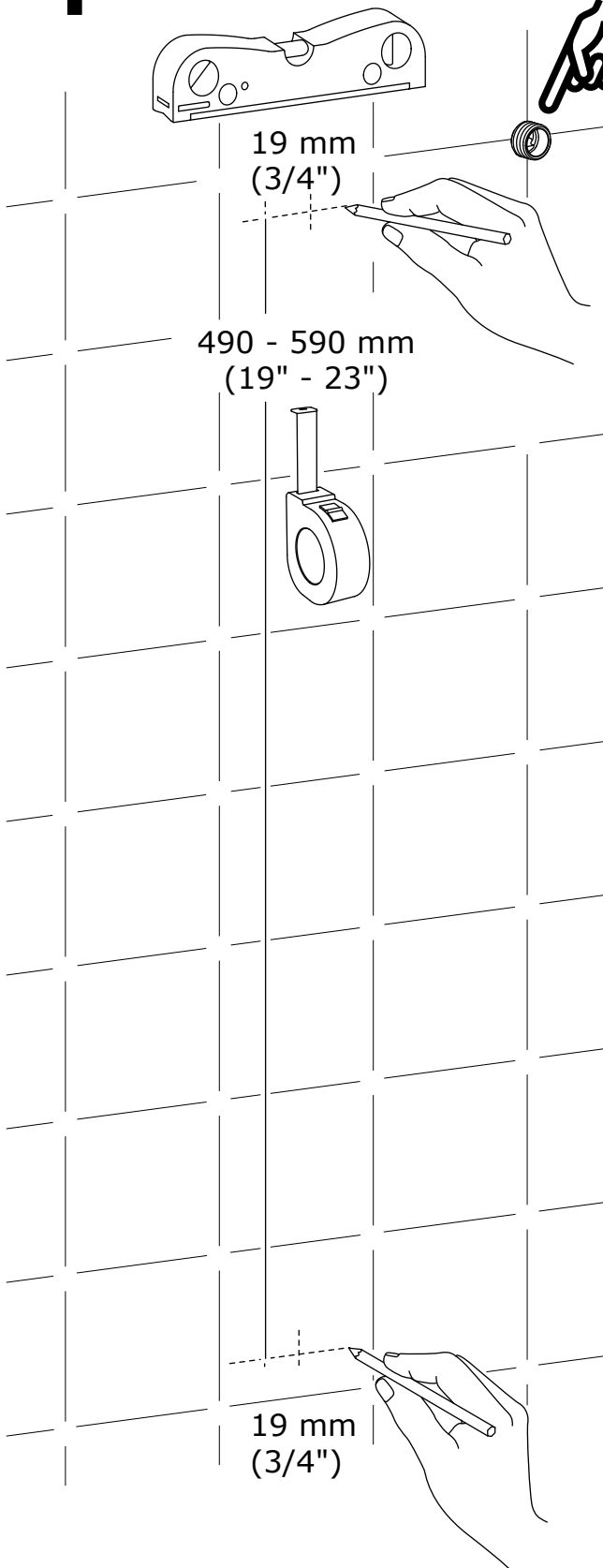

# 2

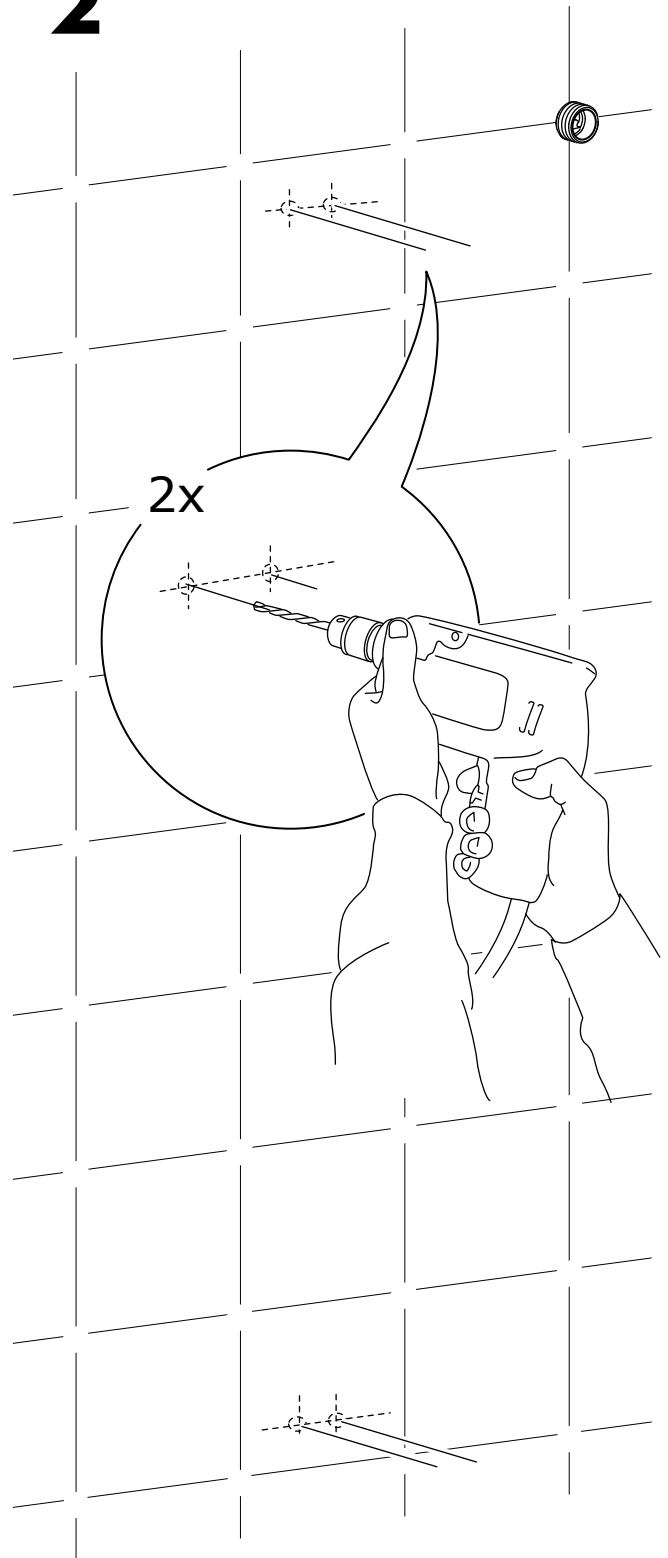

### ENGLISH

Before drilling make sure no water pipes or electric cables are located inside the wall where you want to drill.

### FRANÇAIS

Avant de percer, s'assurer qu'il ne passe aucune conduite d'eau ou fil électrique dans le mur à l'endroit que vous voulez percer.

### ESPAÑOL

Antes de perforar, asegúrate de que no pasa por la pared ninguna conducción de agua o cable eléctrico donde vas a hacerlo.

# 3

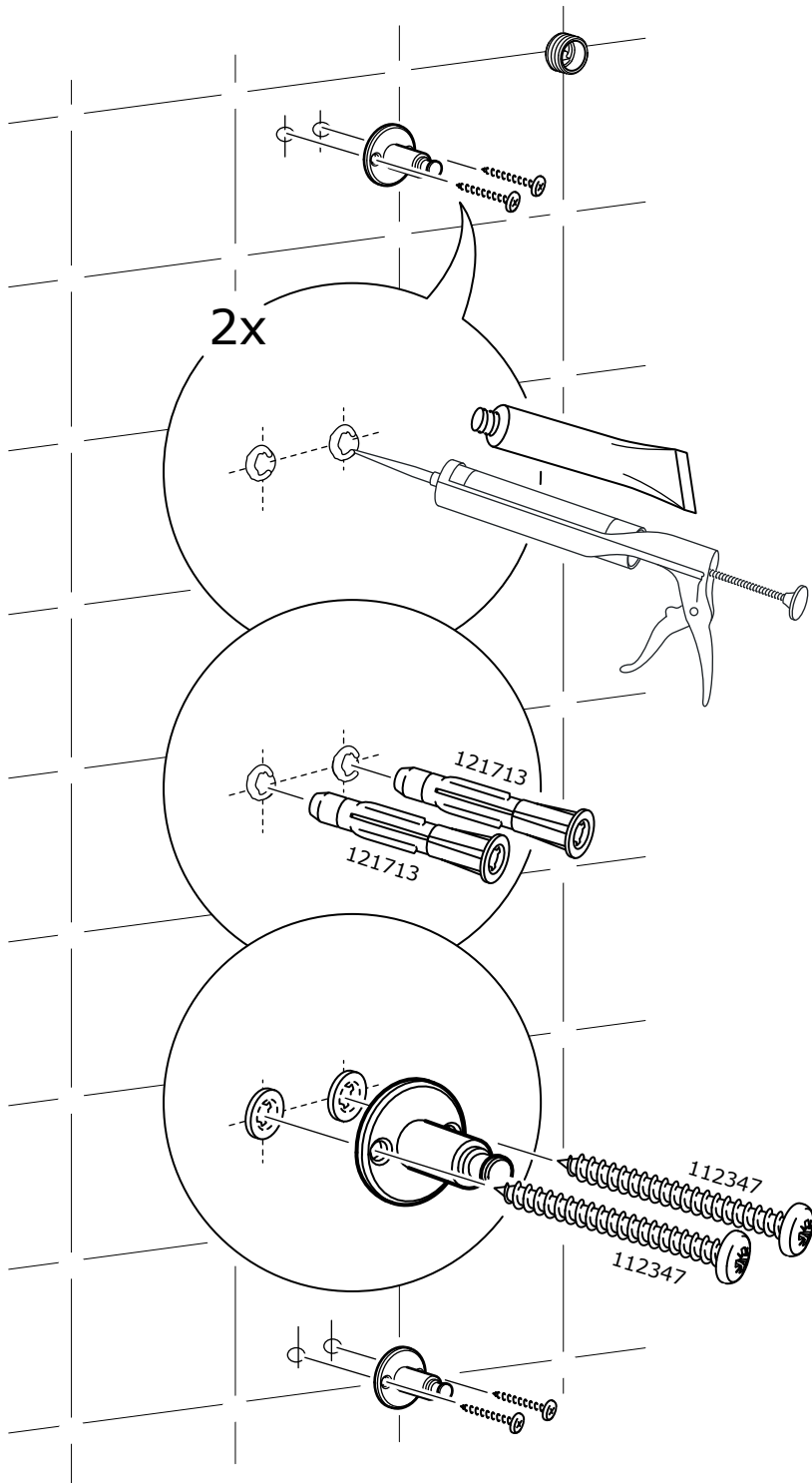

## ENGLISH

NOTE! Silicone is not included.

## FRANÇAIS

ATTENTION ! Silicone non incluse.

## ESPAÑOL

¡ATENCIÓN! Silicona no incluida.

4

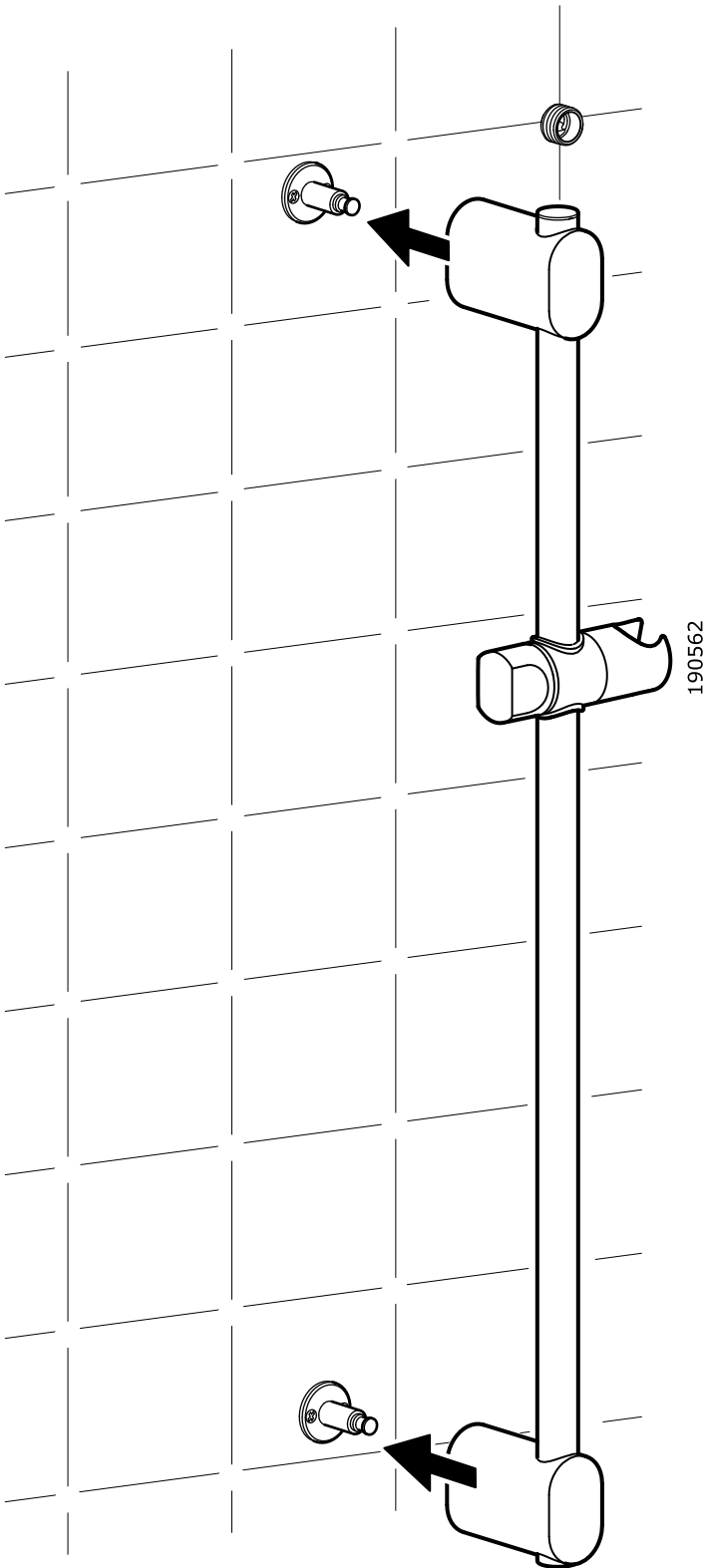

# 5

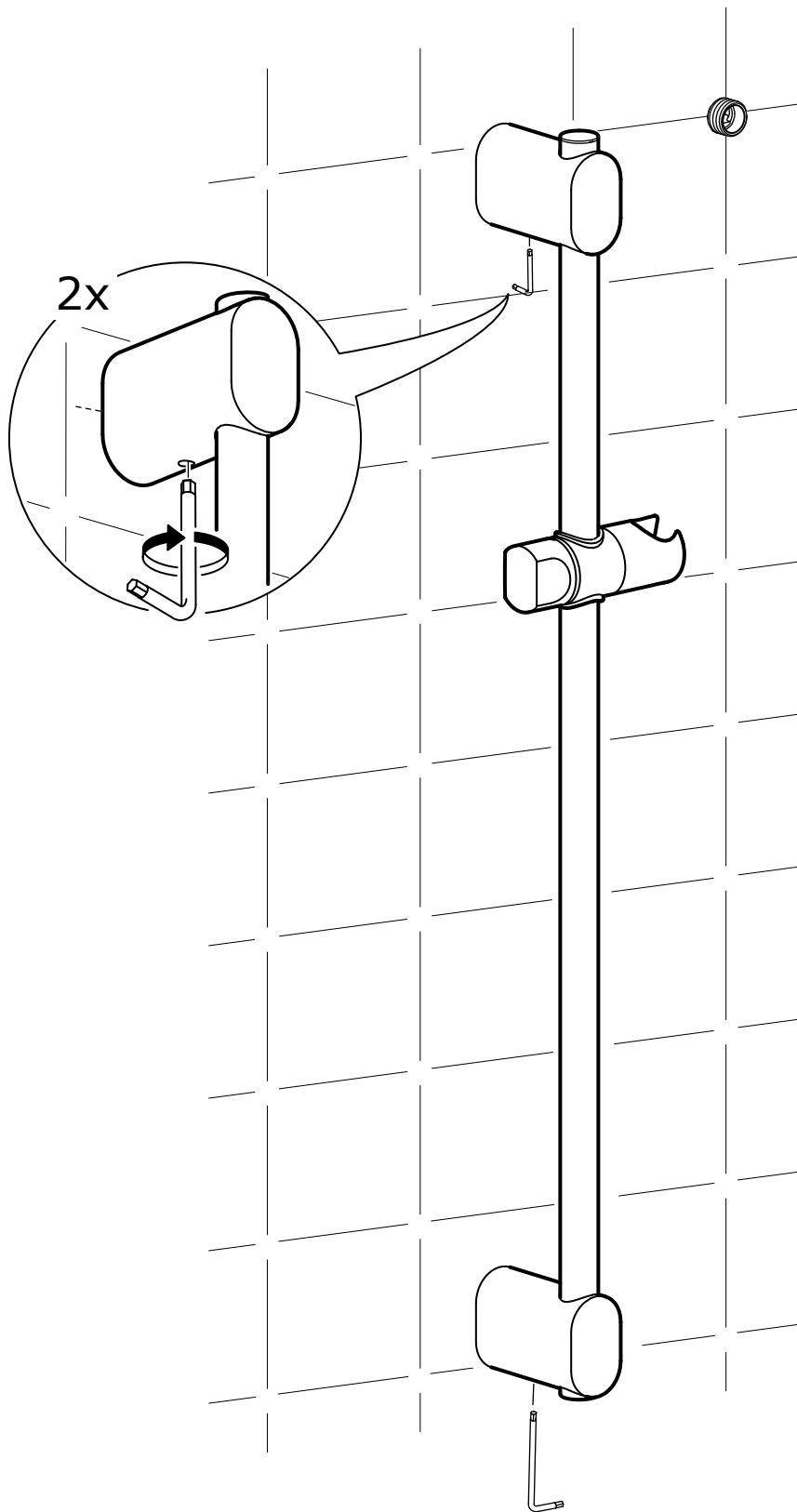



6

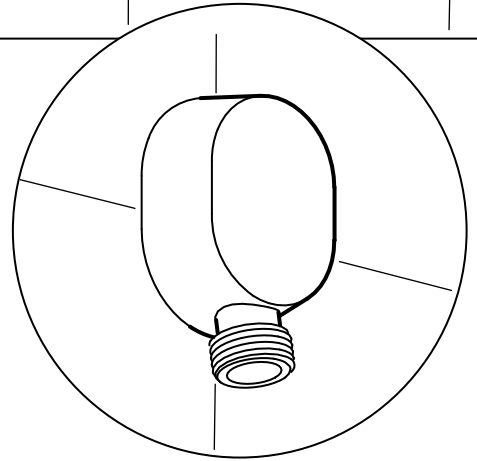
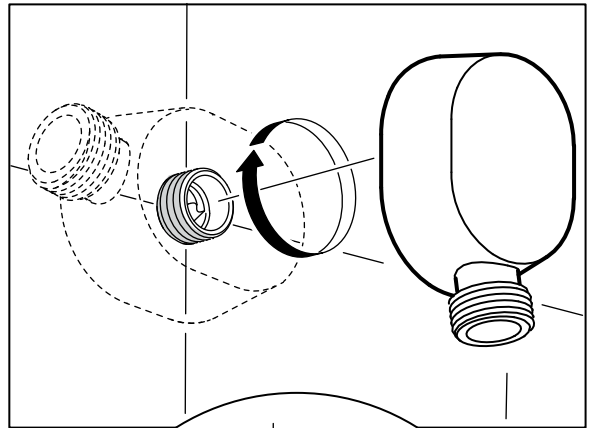
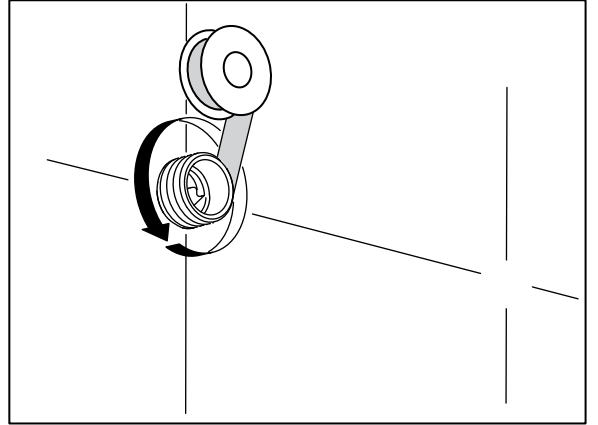
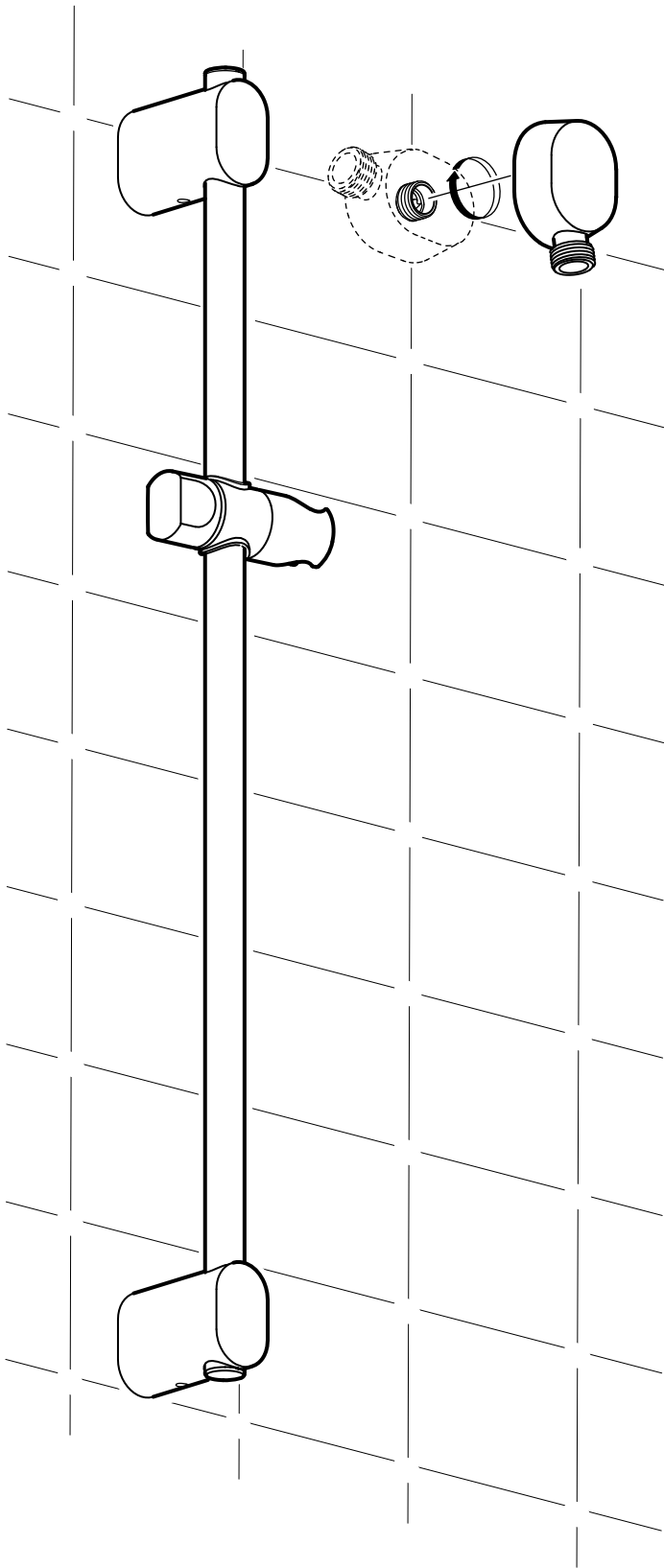

7

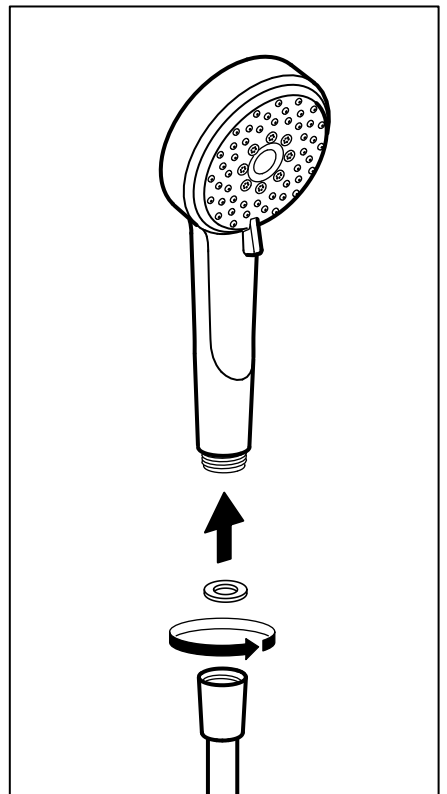
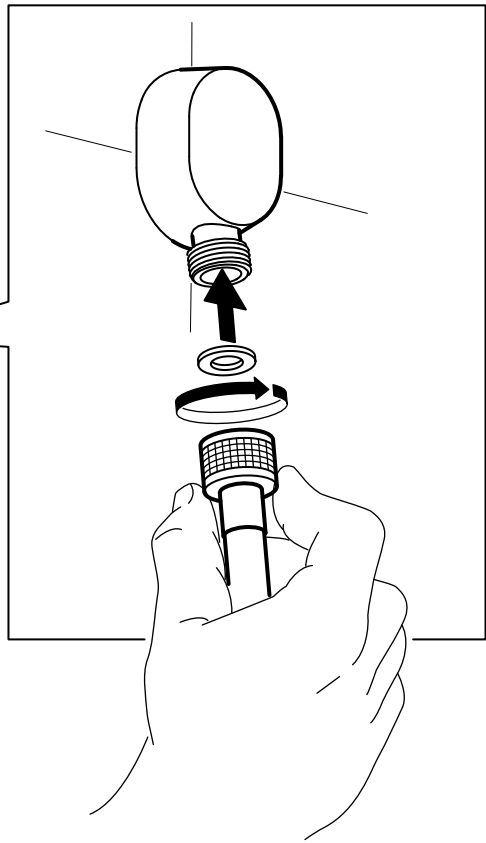
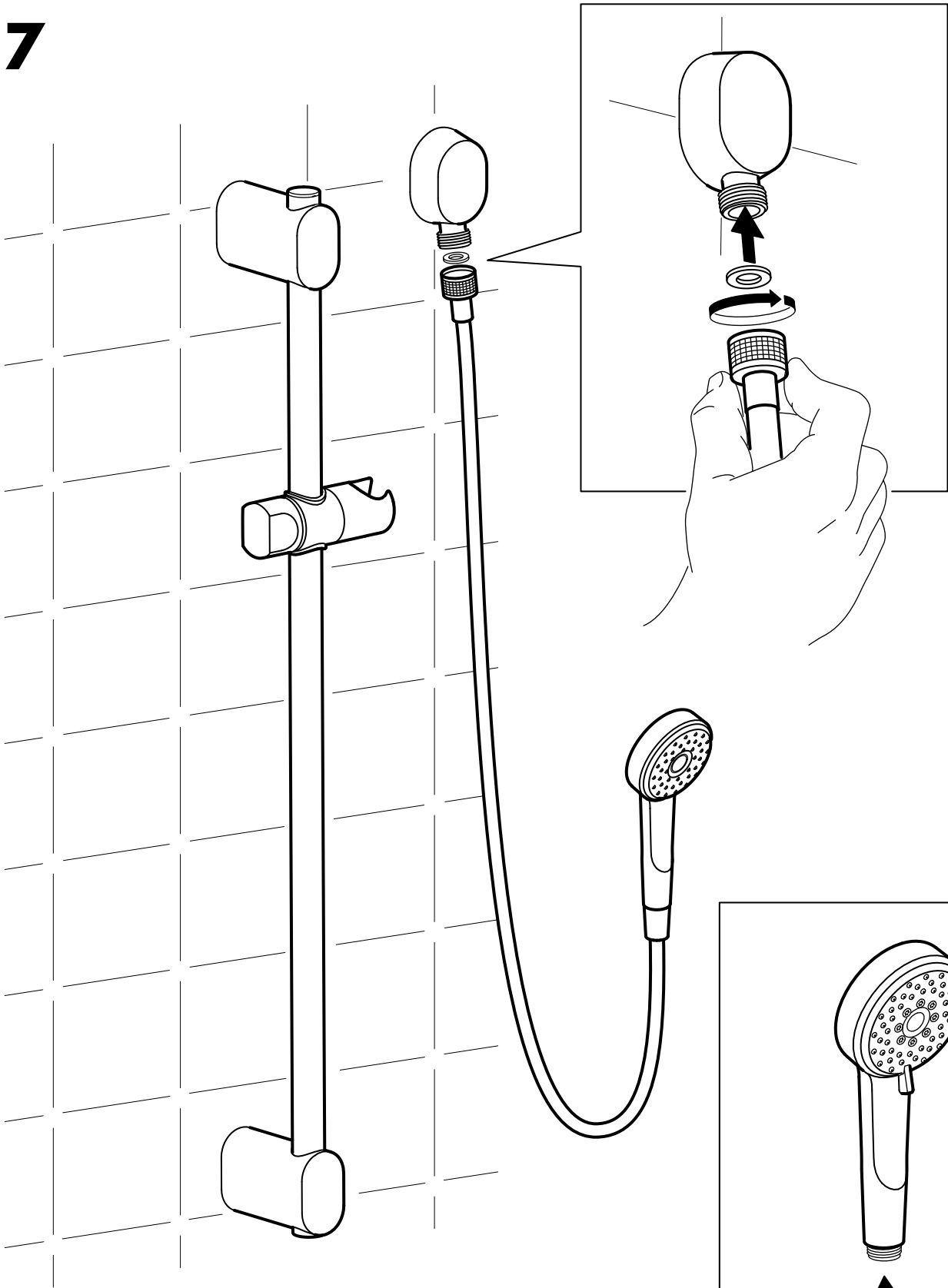

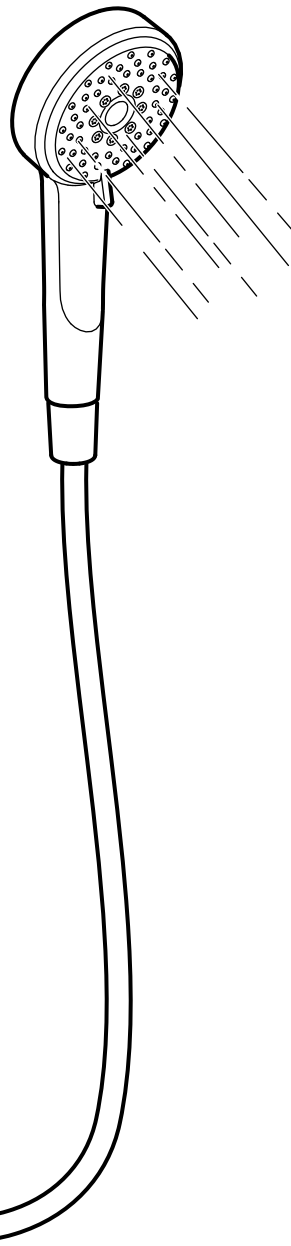
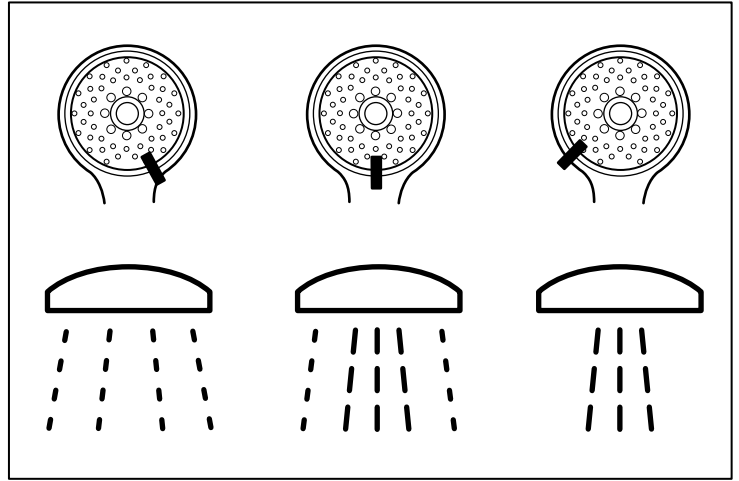
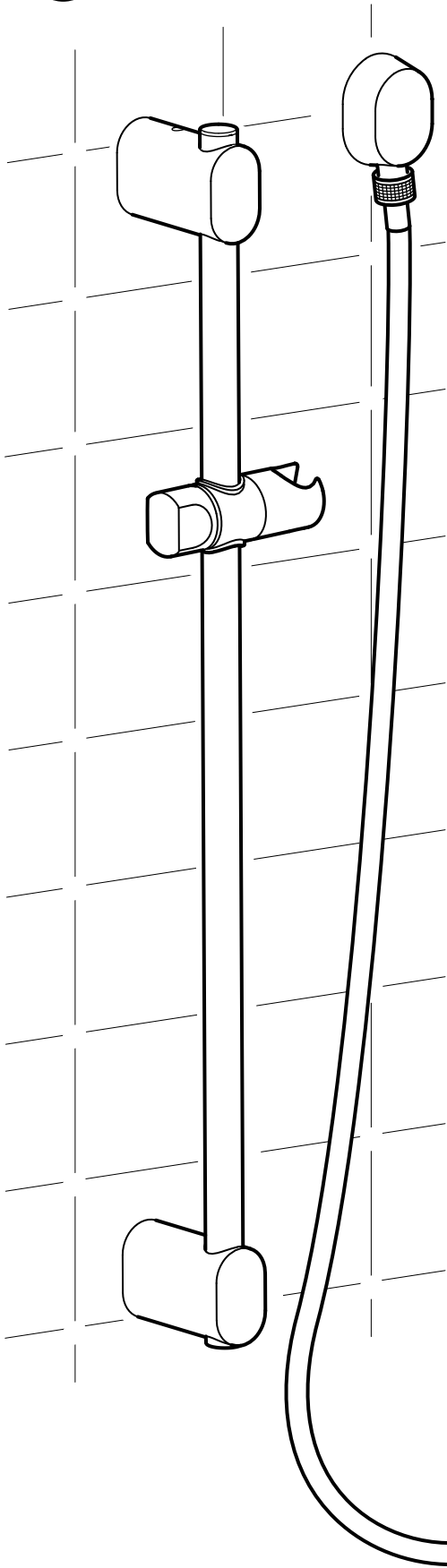

**ENGLISH**

Check at regular intervals to make sure that the installation is not leaking.

**FRANÇAIS**

Vérifier à intervalles réguliers que l'installation ne fuit pas.

**ESPAÑOL**

Comprobar a intervalos regulares que la instalación no gotee.

