

BRUSALI

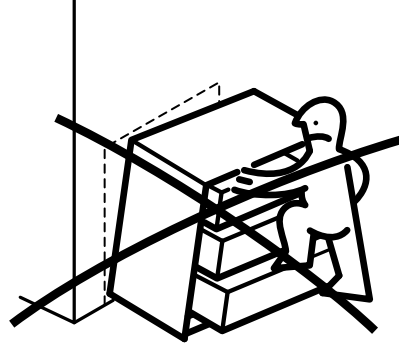

Design and Quality
IKEA of Sweden

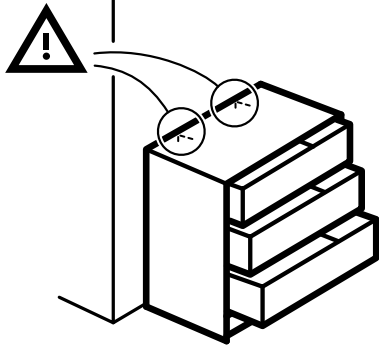

WARNING

Serious or fatal crushing injuries can occur from furniture tip-over. ALWAYS secure this furniture to the wall using tip-over restraints. To further reduce the risk of serious injury and death from tip-overs:

- Place heaviest items in the lower drawer.
- Do not set TVs or other heavy objects on top of this product.
- Never let children climb or hang on drawers, doors, or shelves.

ATTENTION

Risque de blessures graves ou mortelles en cas de basculement du meuble. TOUJOURS fixer ce meuble au mur à l'aide des fixations anti-basculement. Pour encore réduire les risques de blessures graves ou mortelles dus au basculement du meuble :

- Placer les objets les plus lourds dans le tiroir du bas.
- Ne pas poser de TV ou d'objet lourd sur le dessus de ce produit.
- Ne jamais laisser les enfants grimper ou s'accrocher aux tiroirs, portes ou tablettes.

ADVERTENCIA

Si el mueble vuelca, puede provocar lesiones muy graves e incluso mortales. Fija SIEMPRE este mueble a la pared utilizando los accesorios antivuelco. Para reducir aún más el riesgo de lesiones graves o incluso mortales causadas por el vuelco del mueble:

- Guarda los objetos más pesados en el cajón inferior.
- No pongas un TV u otros objetos pesados encima de este producto.
- Evita que los niños suban encima del mueble o se cuelguen de los cajones, las puertas o los estantes.

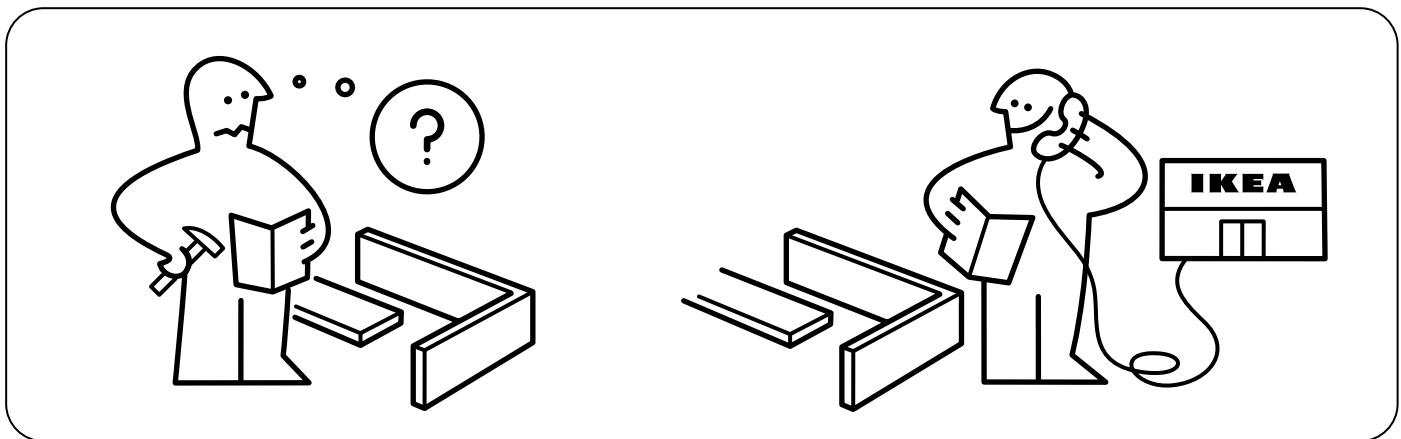
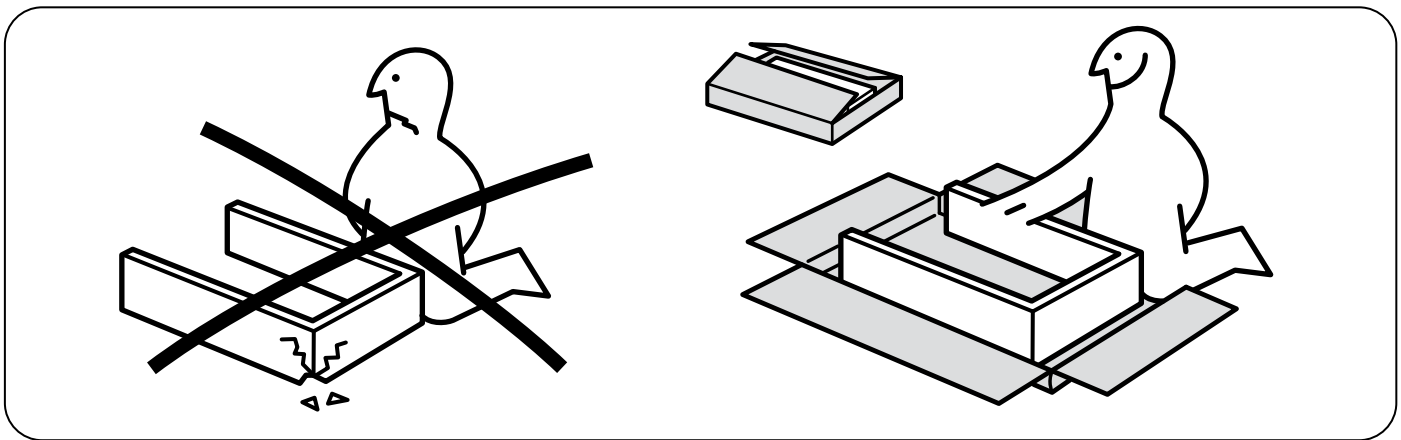
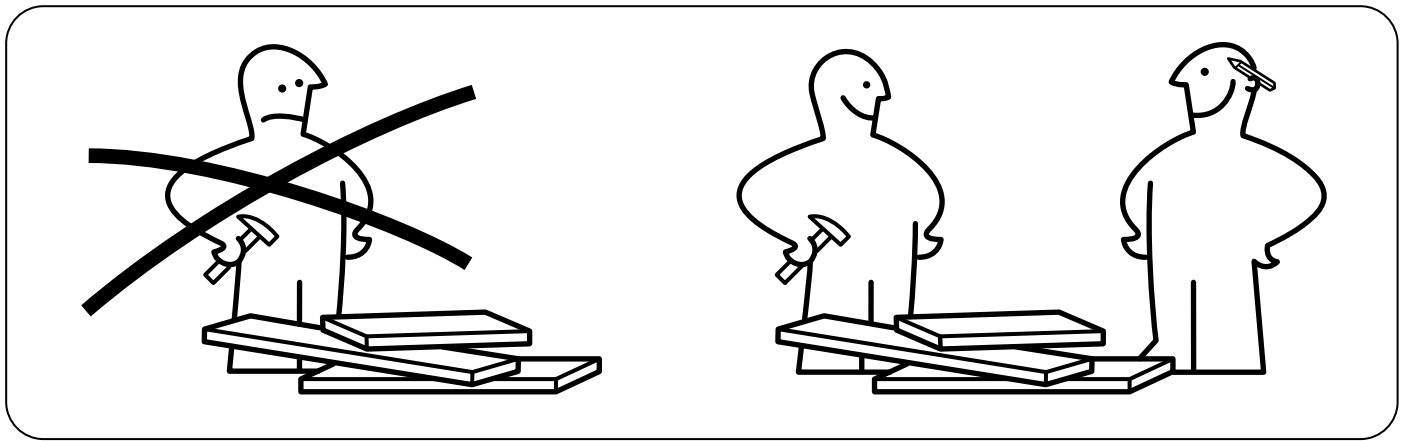
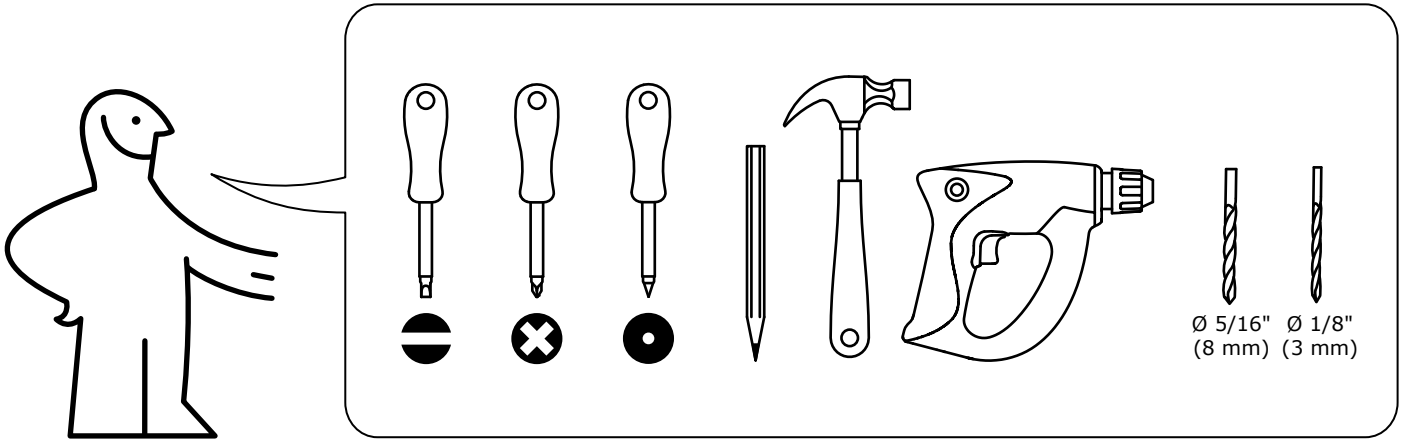

1

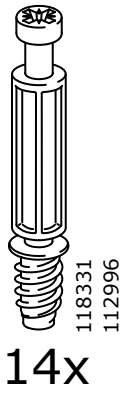

14x



14x

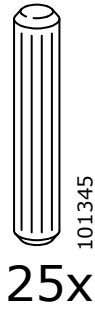

25x

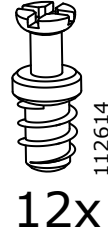

12x



12x

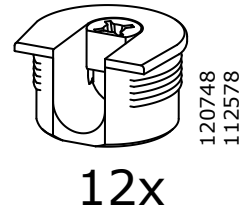

12x

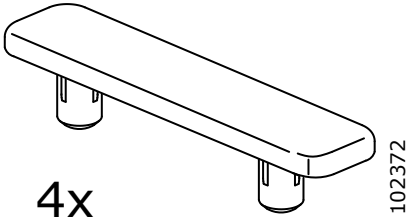

4x

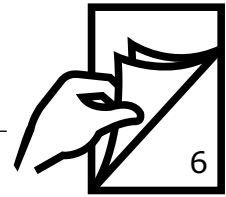

6

2

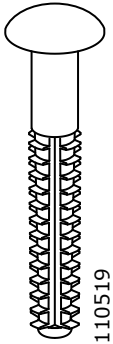

12x

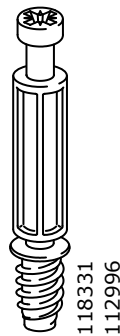

12x

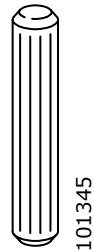

12x

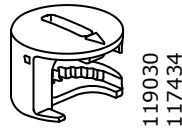

12x



6x



12x



6x

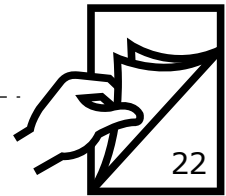

22

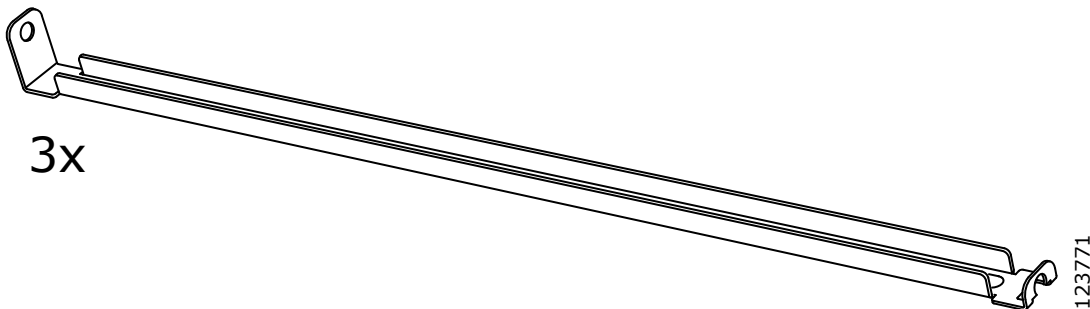

3x

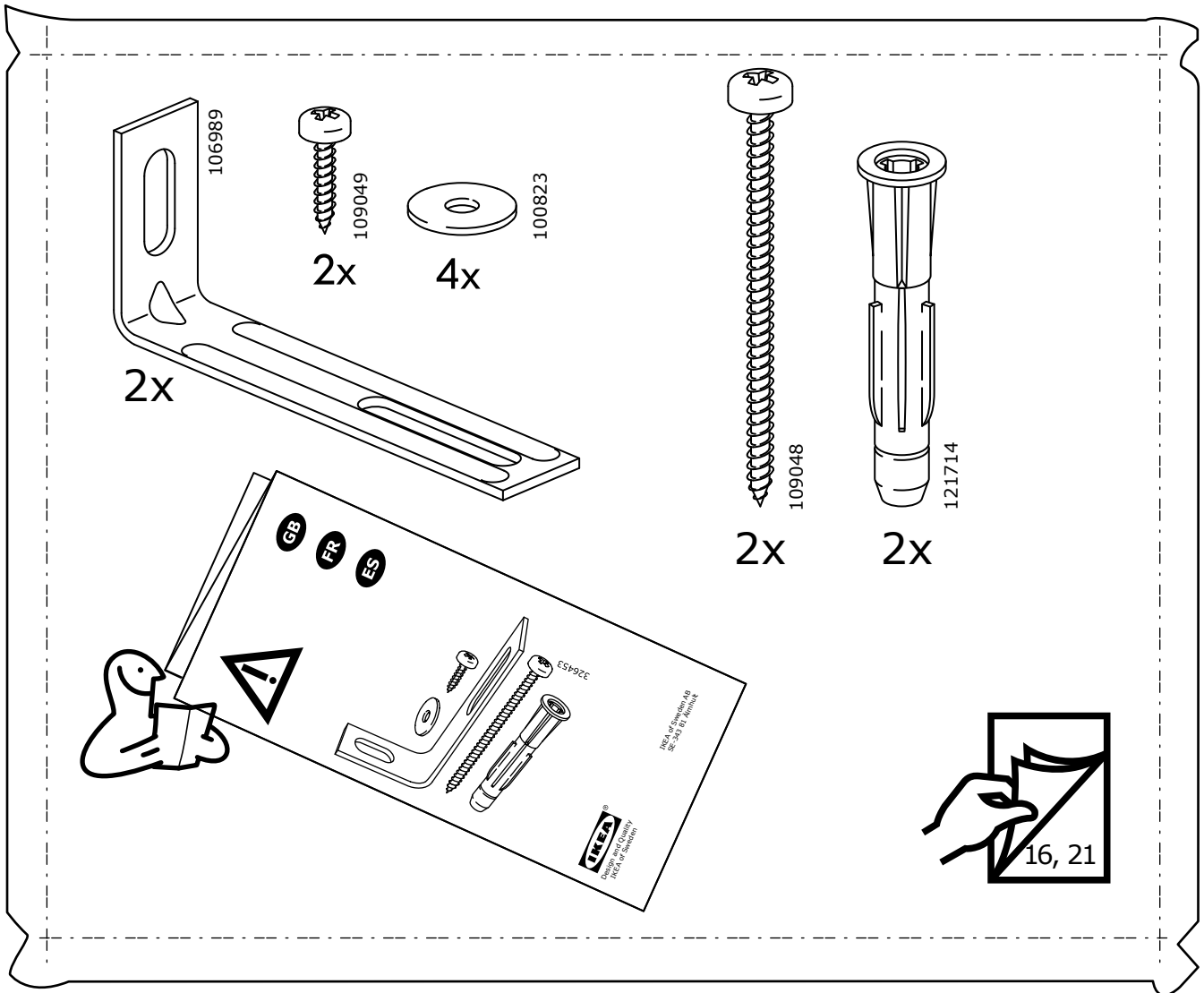
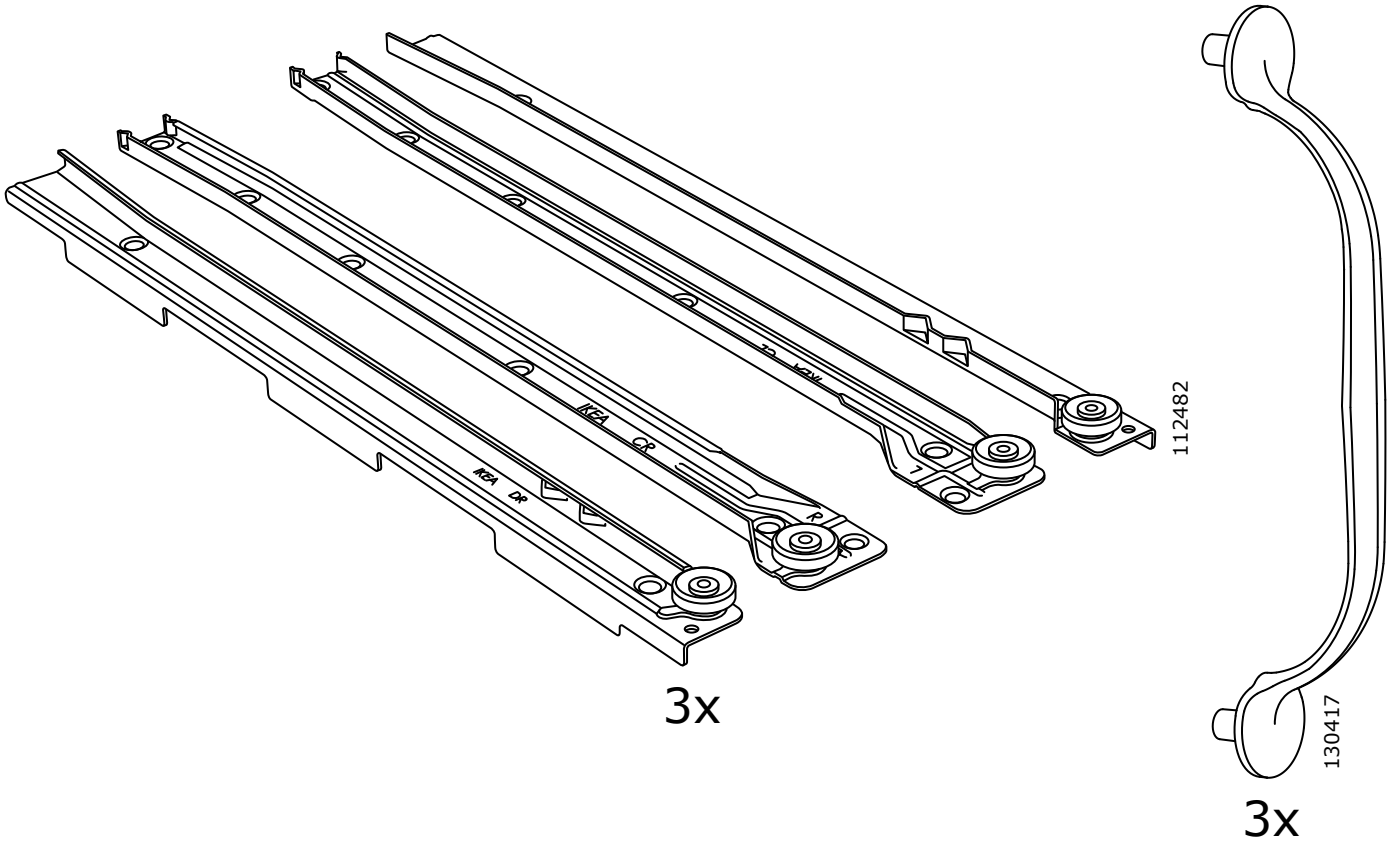

326453

1

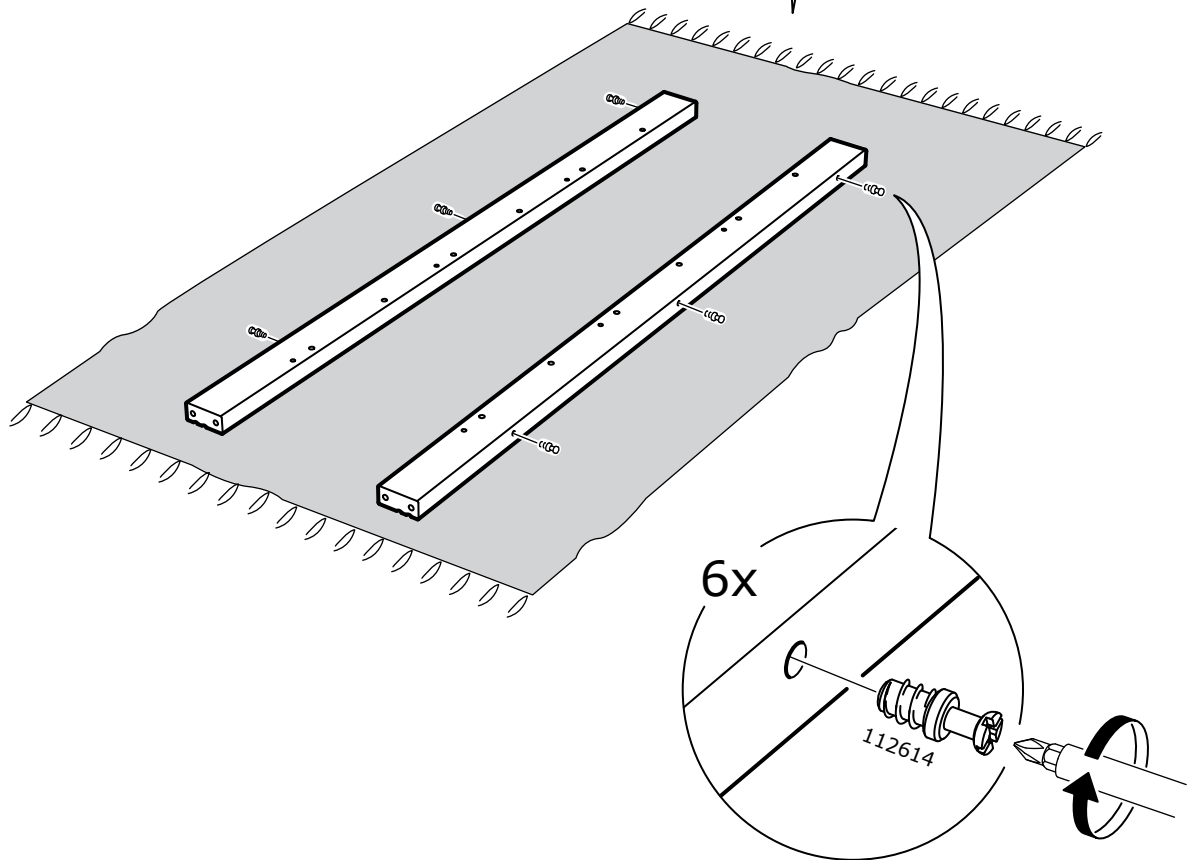
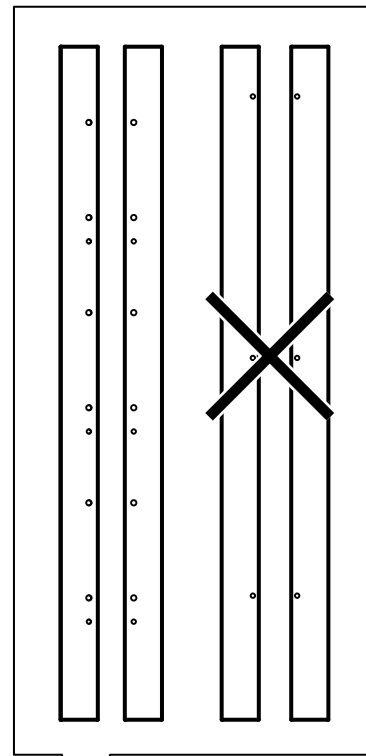
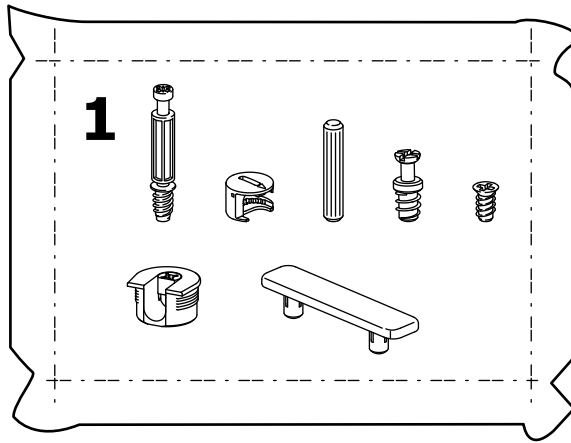

2

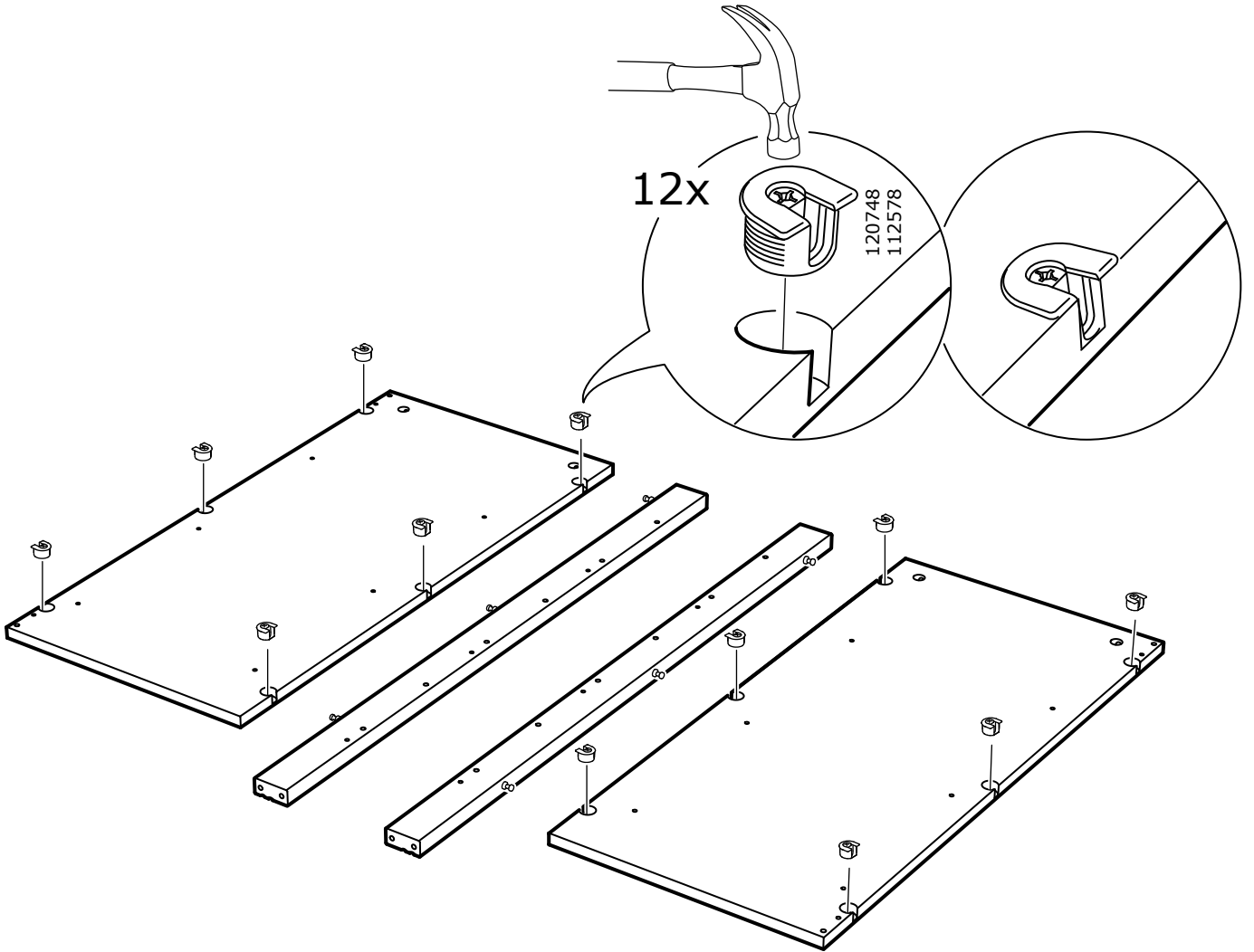

3

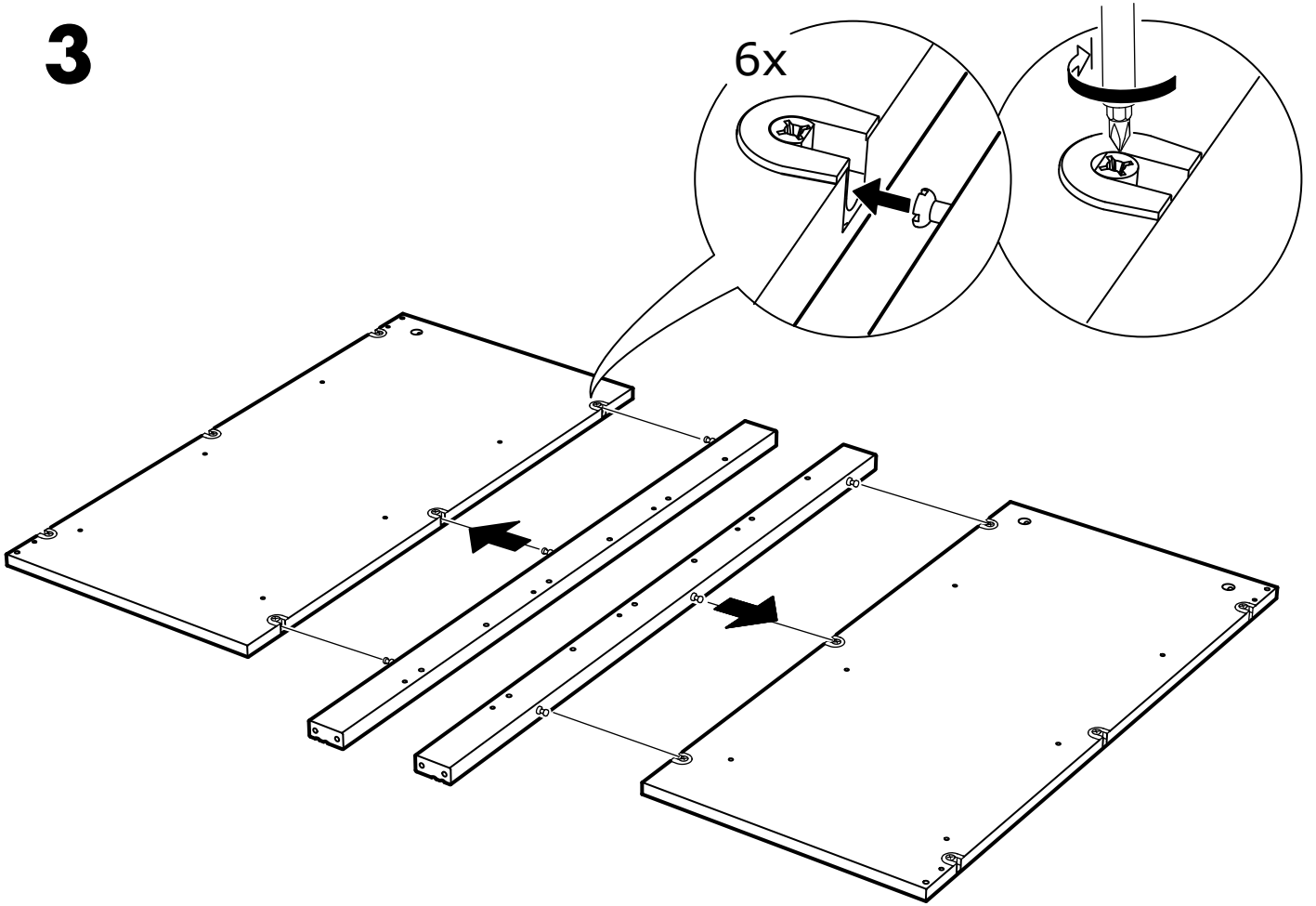

4

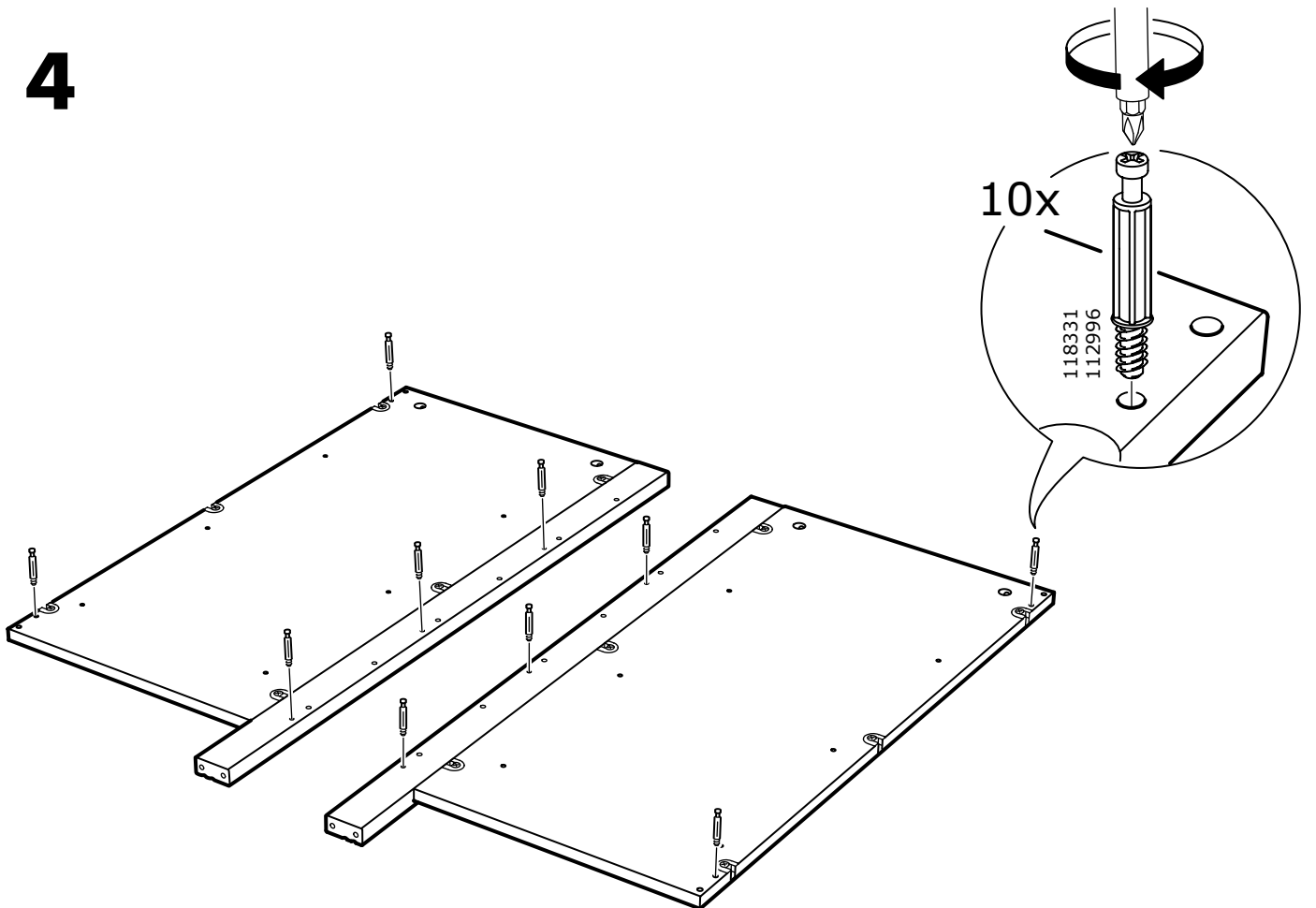

5

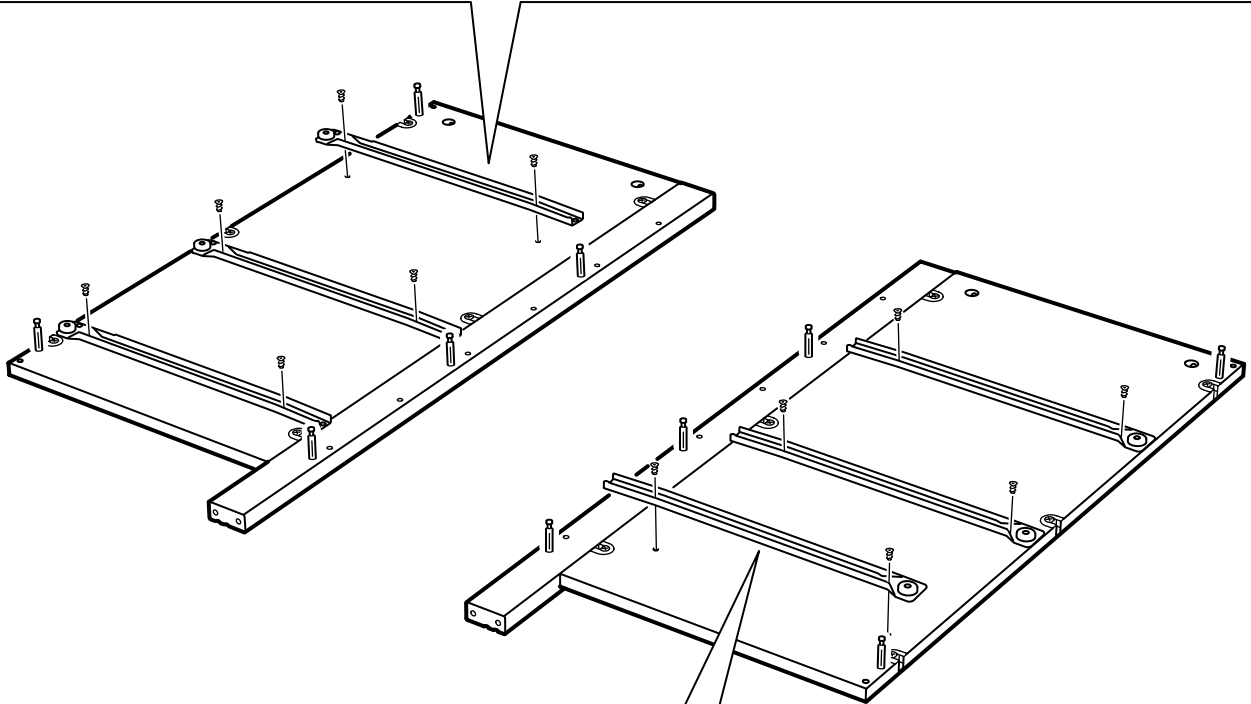
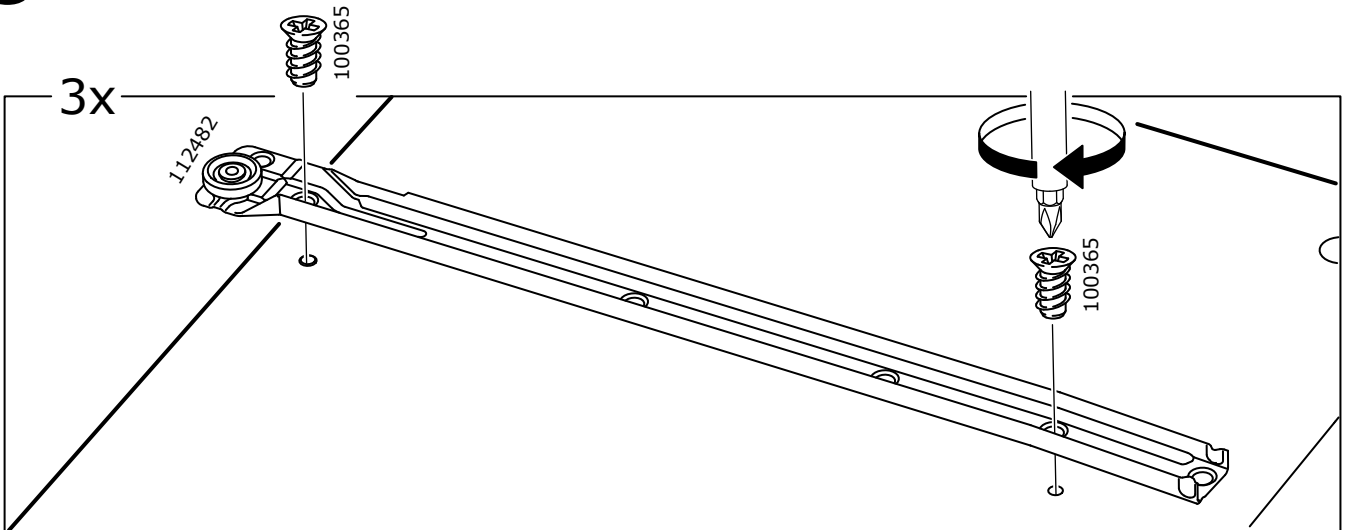

6

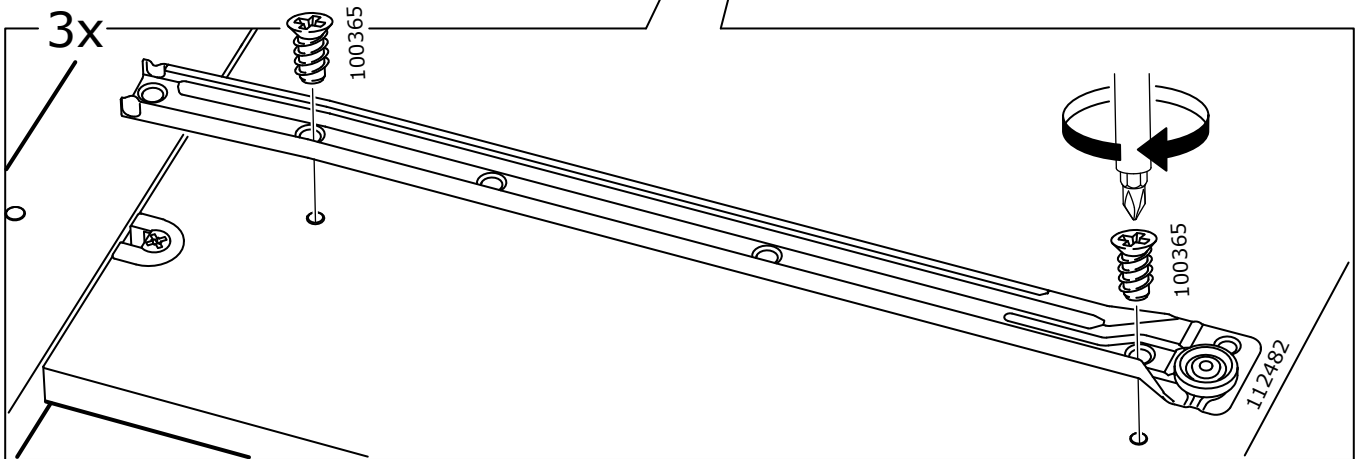

7

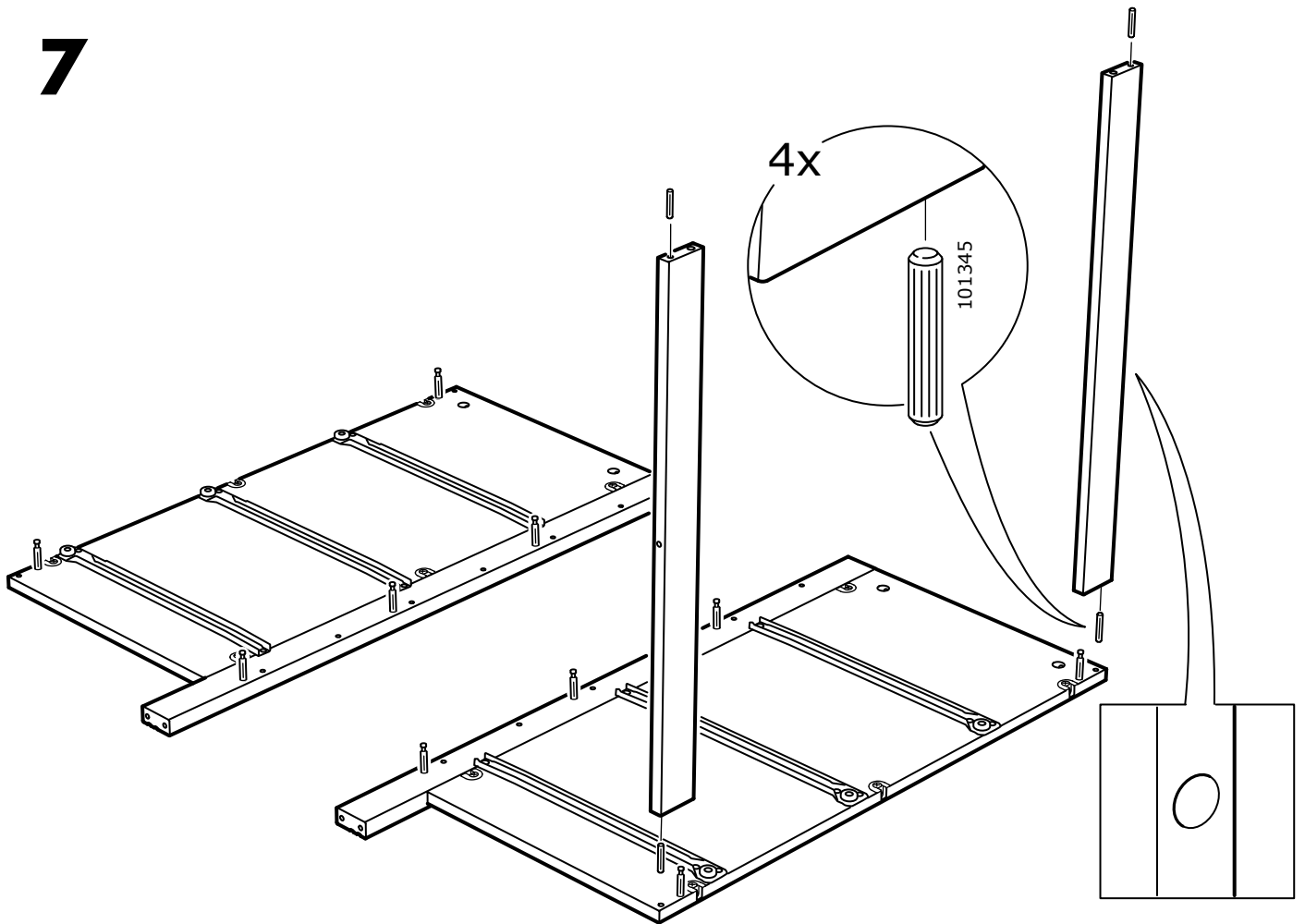

8

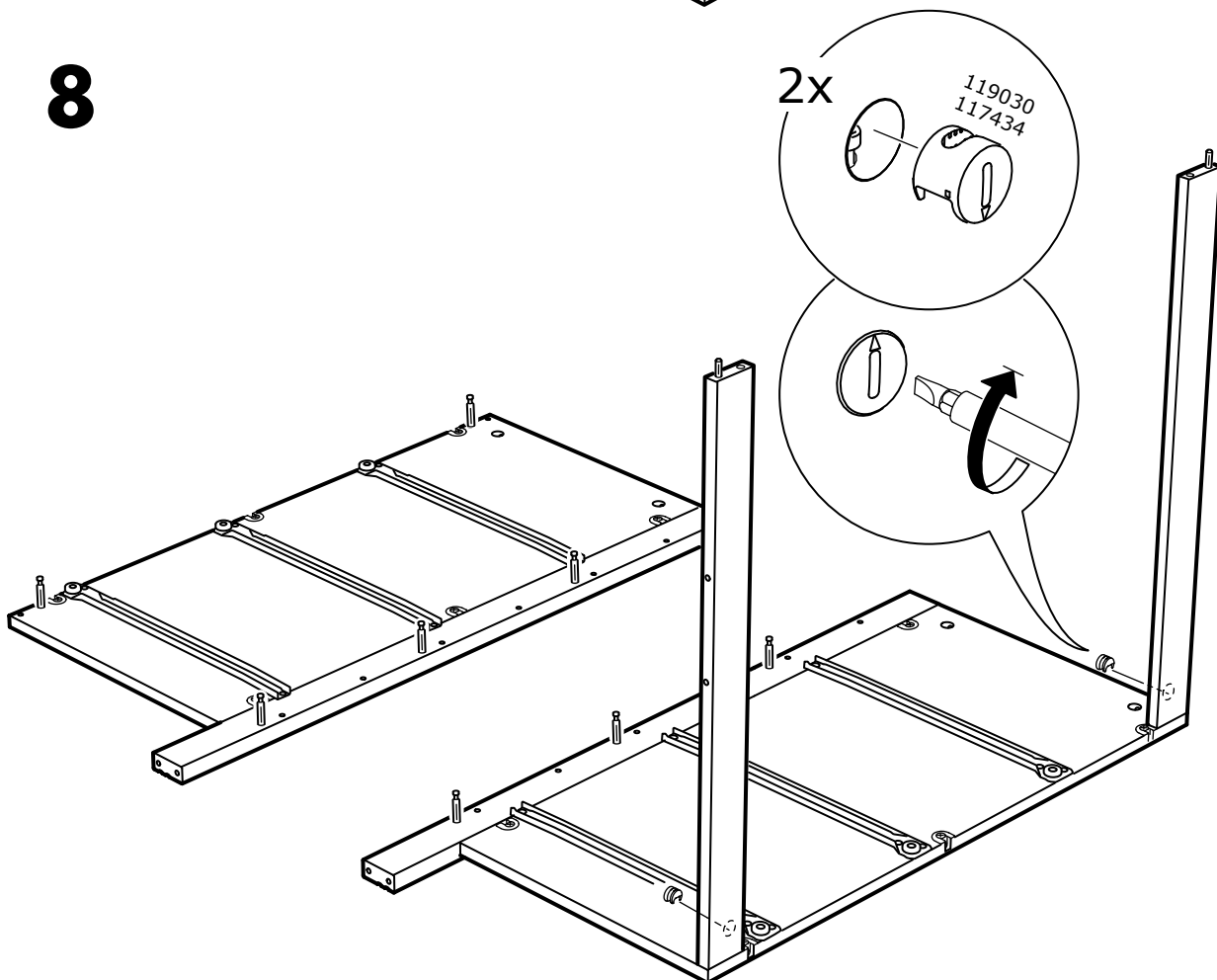

9

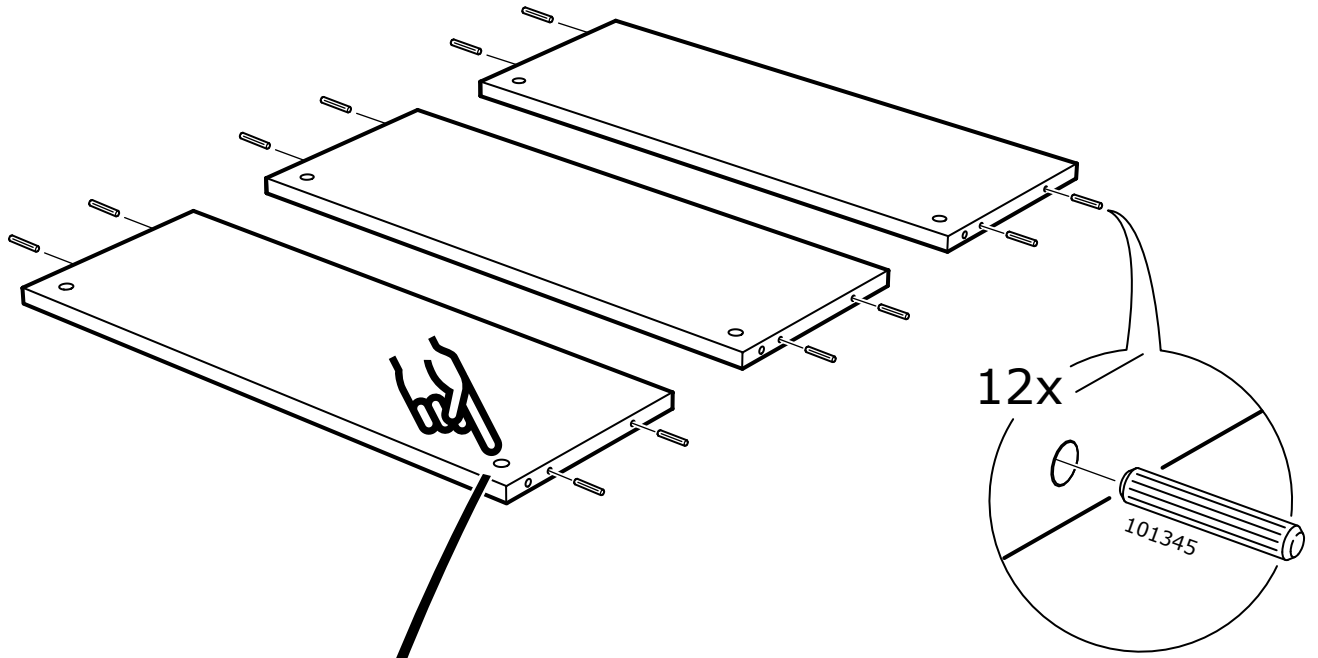

10

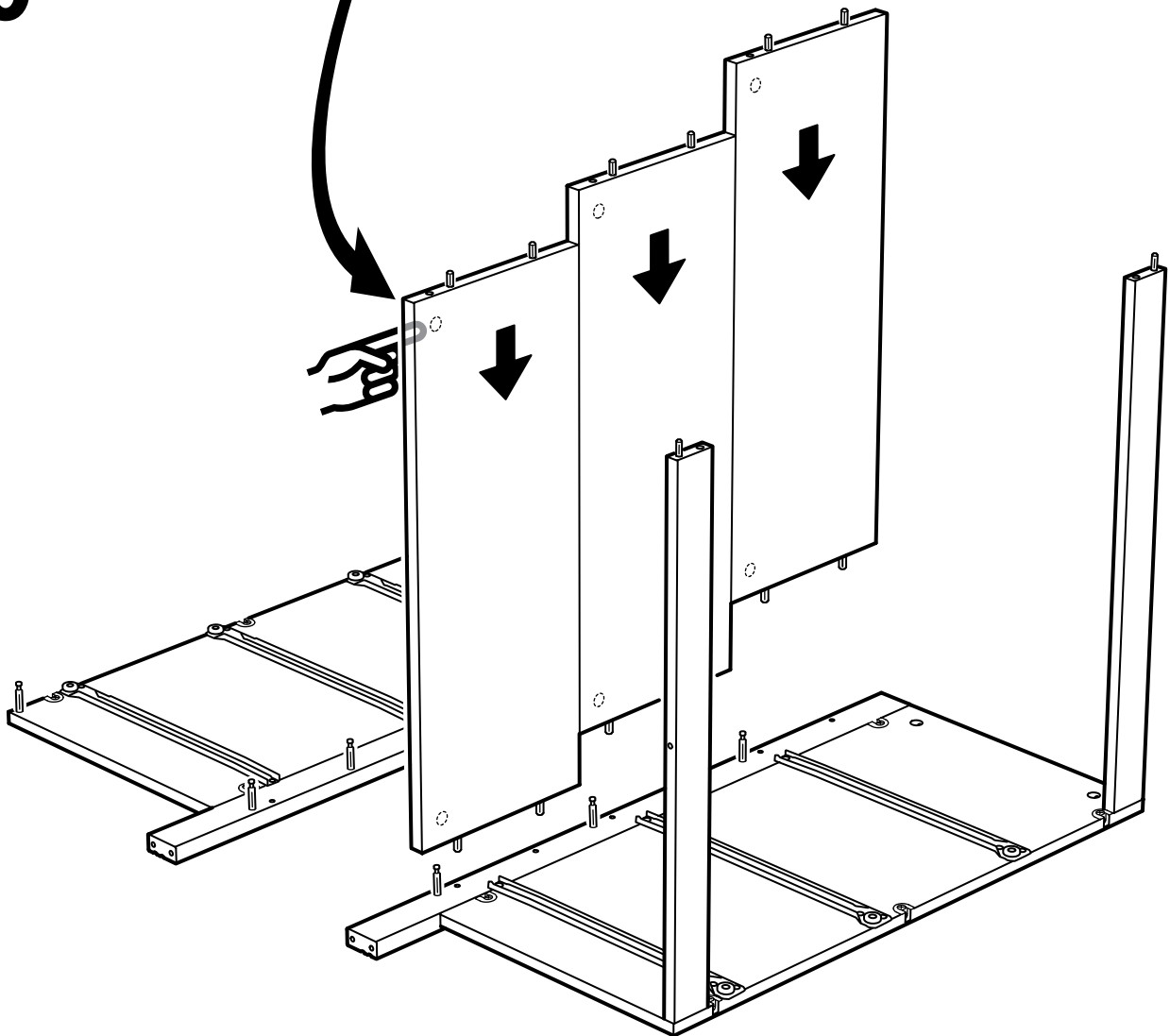

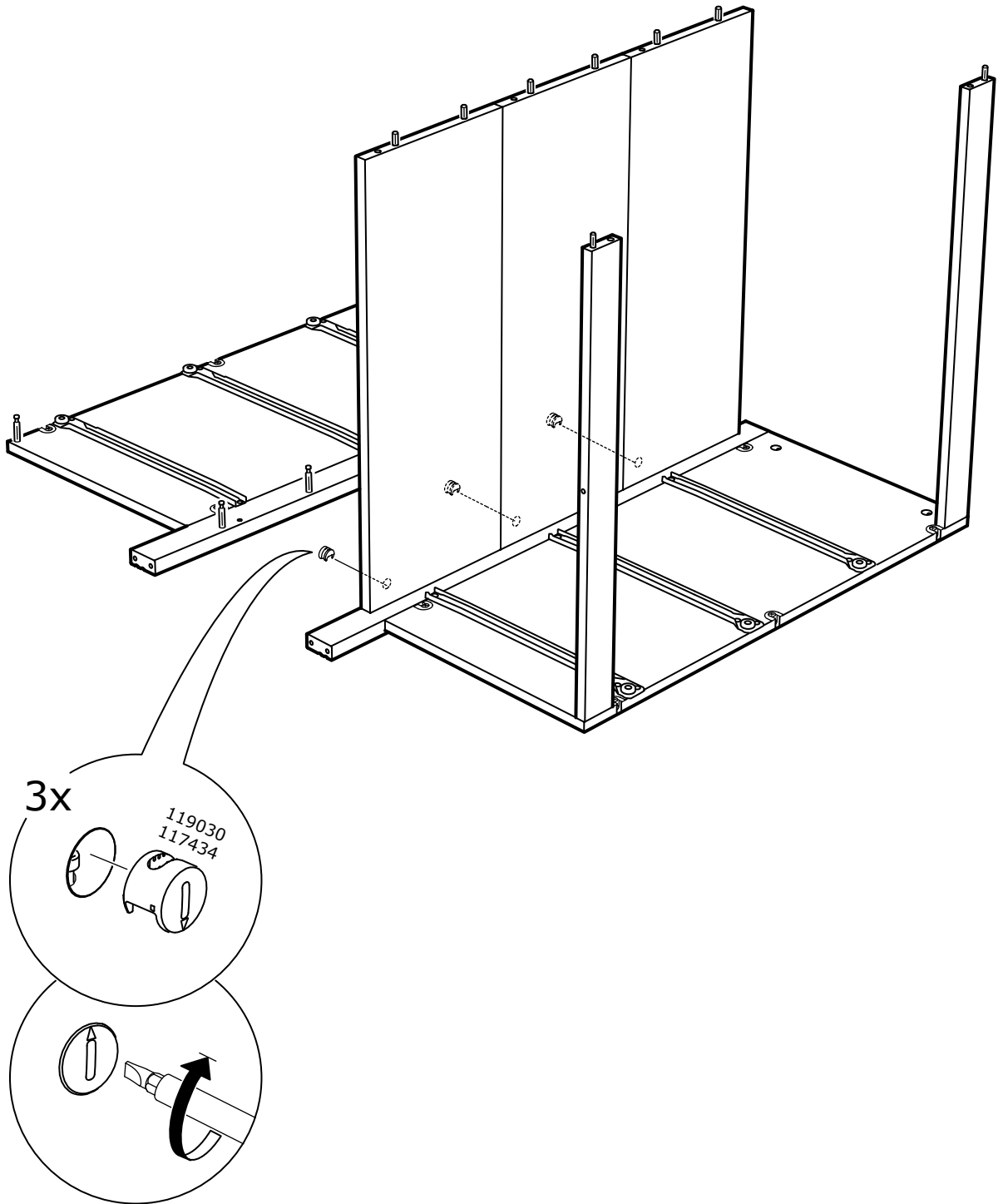

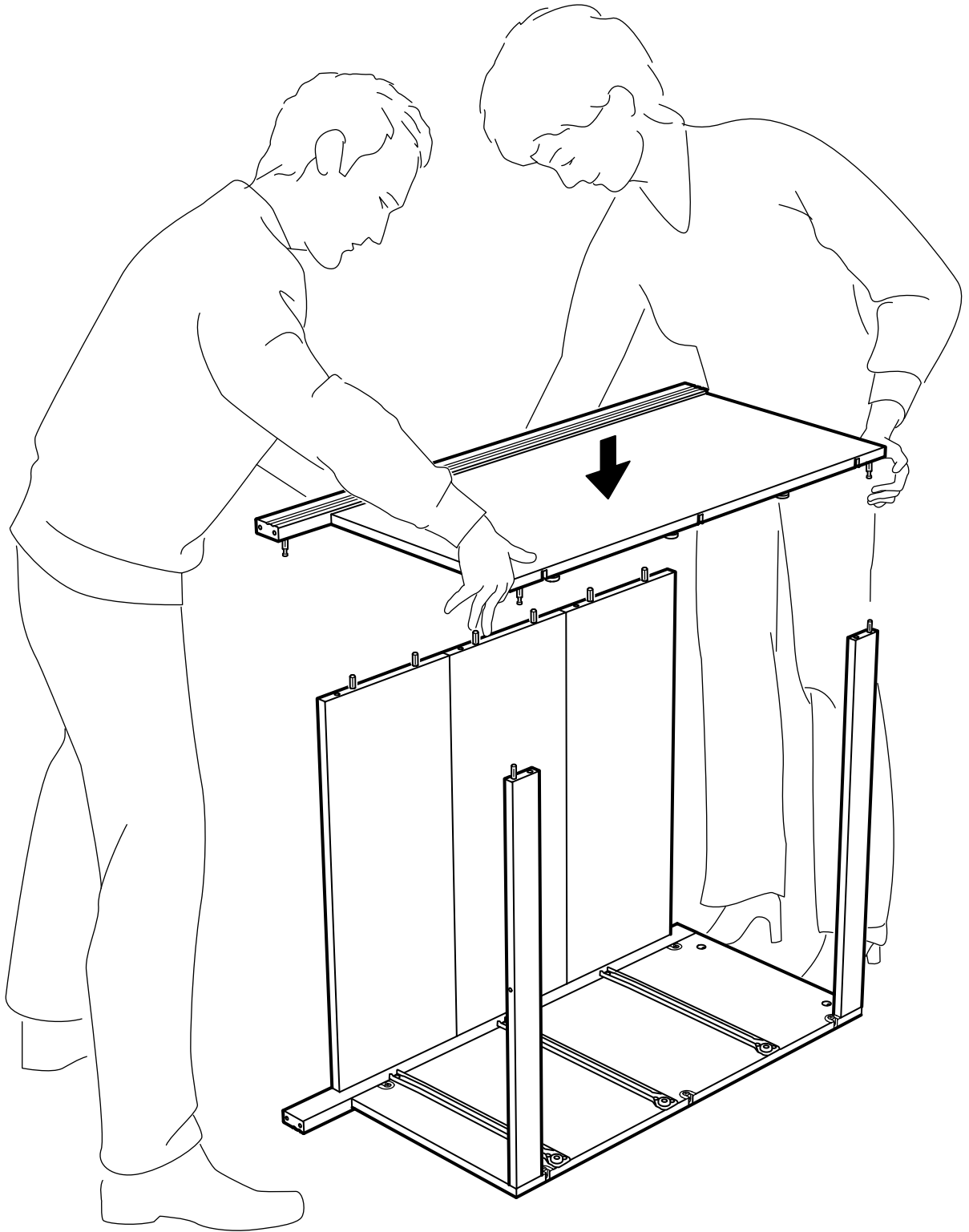

13

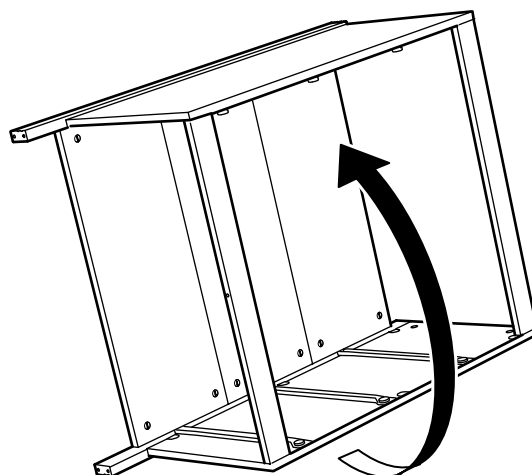
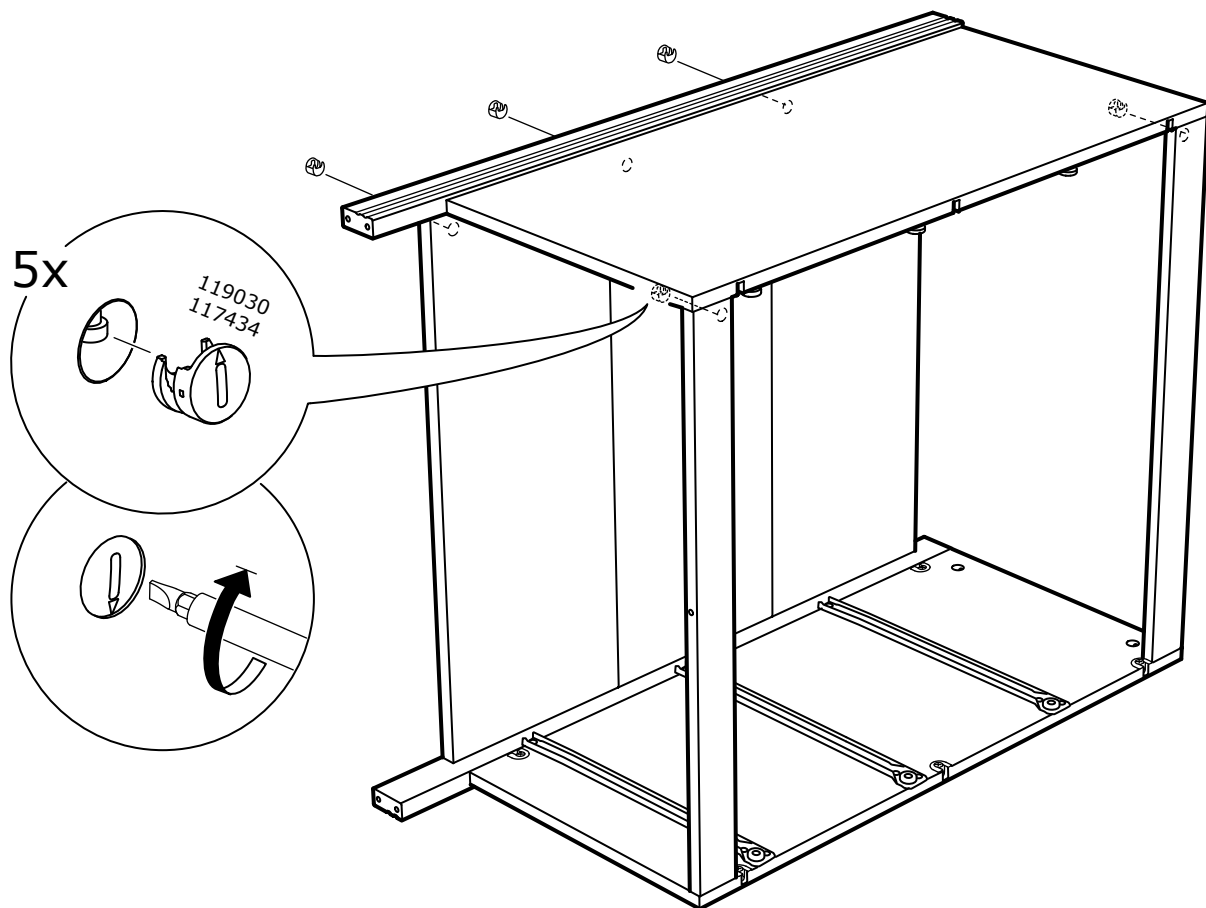

14

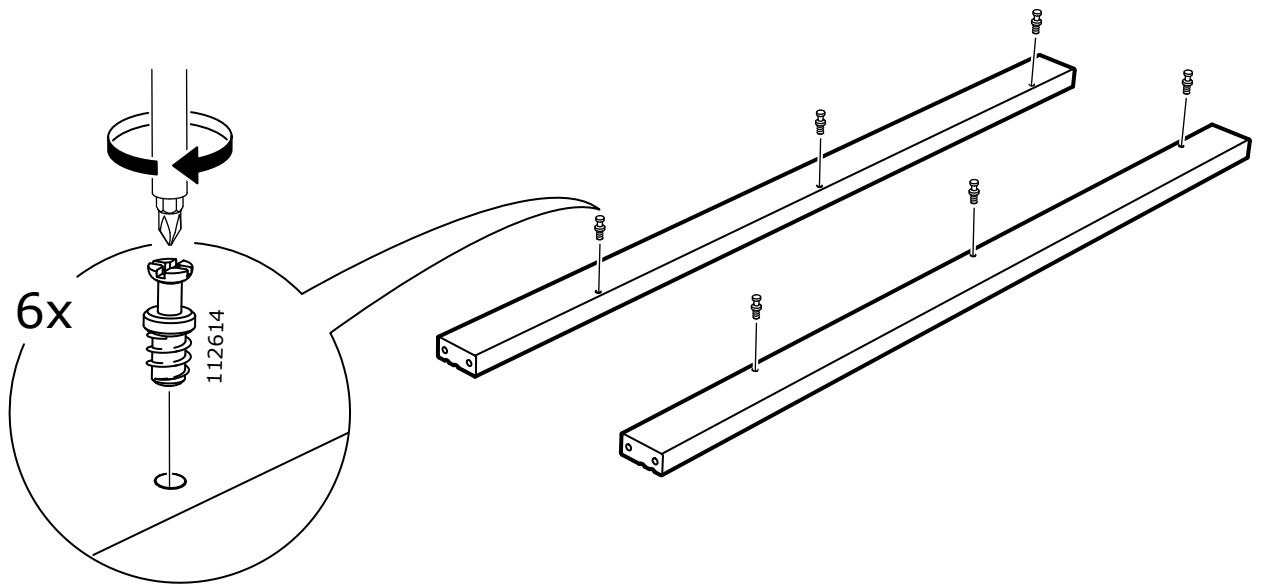

15

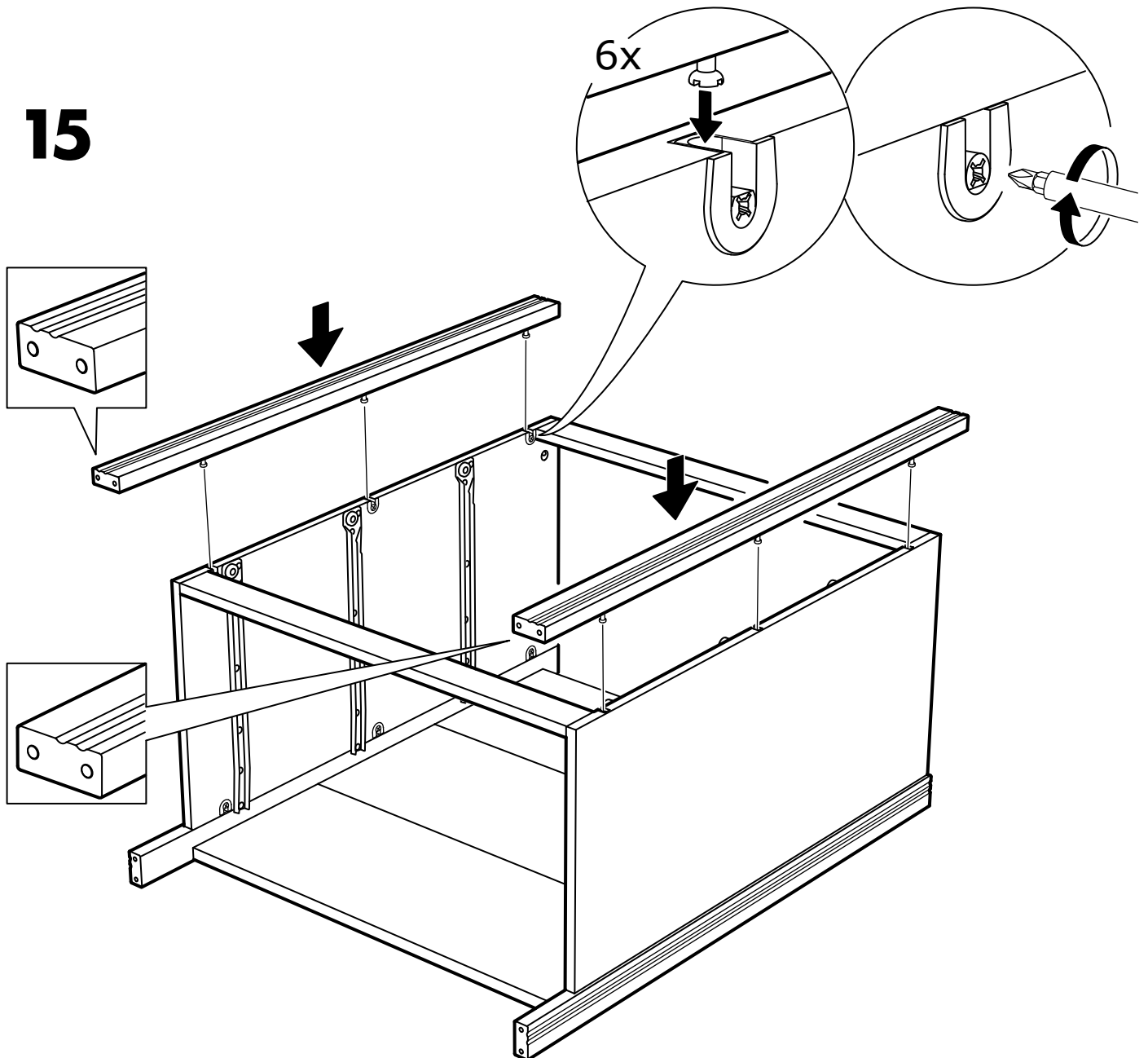

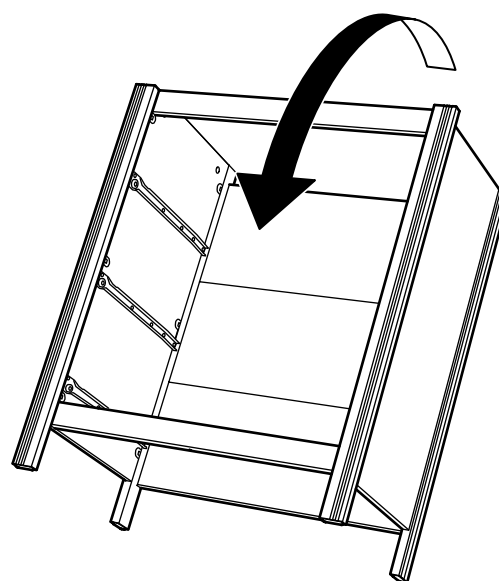
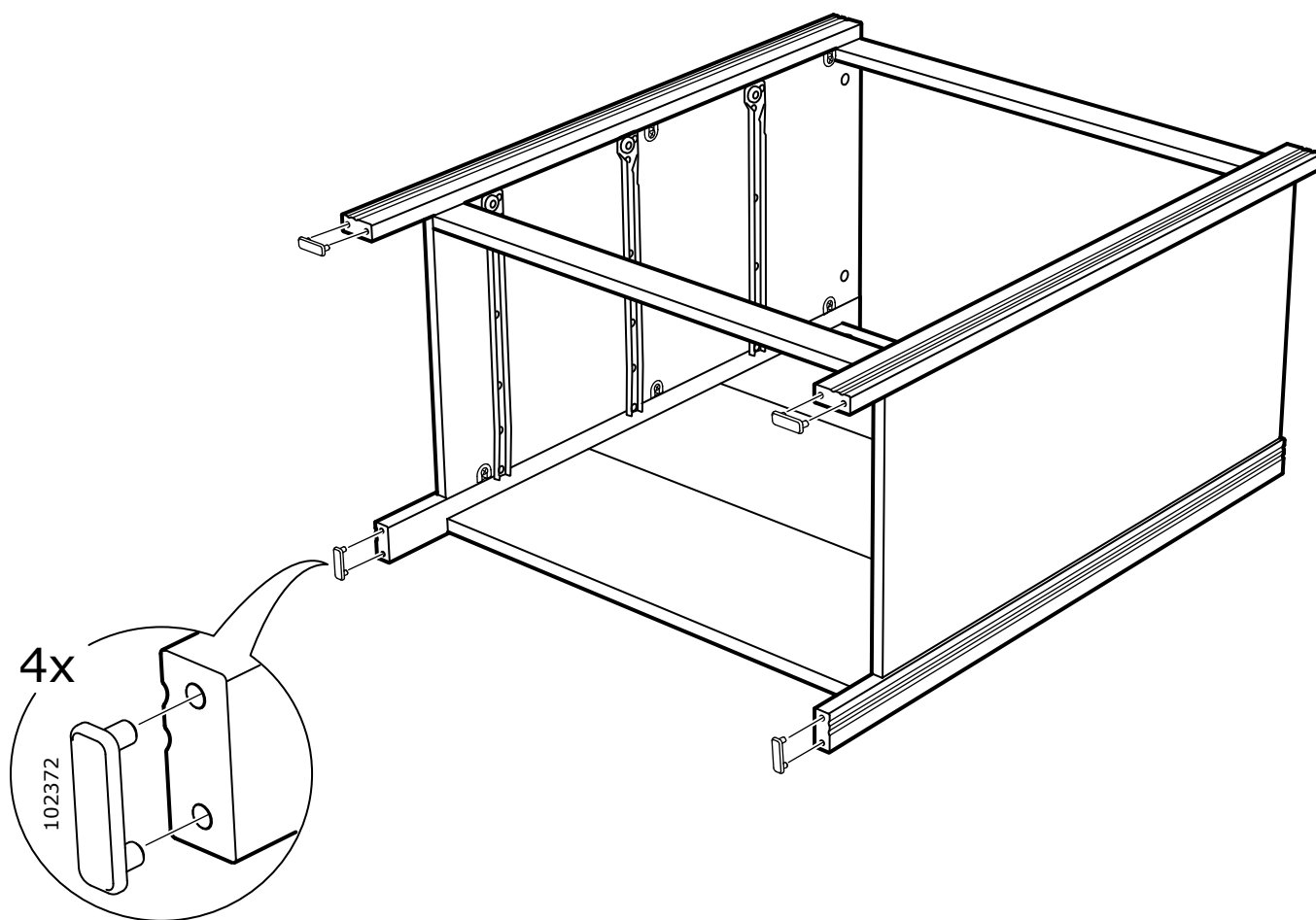

17

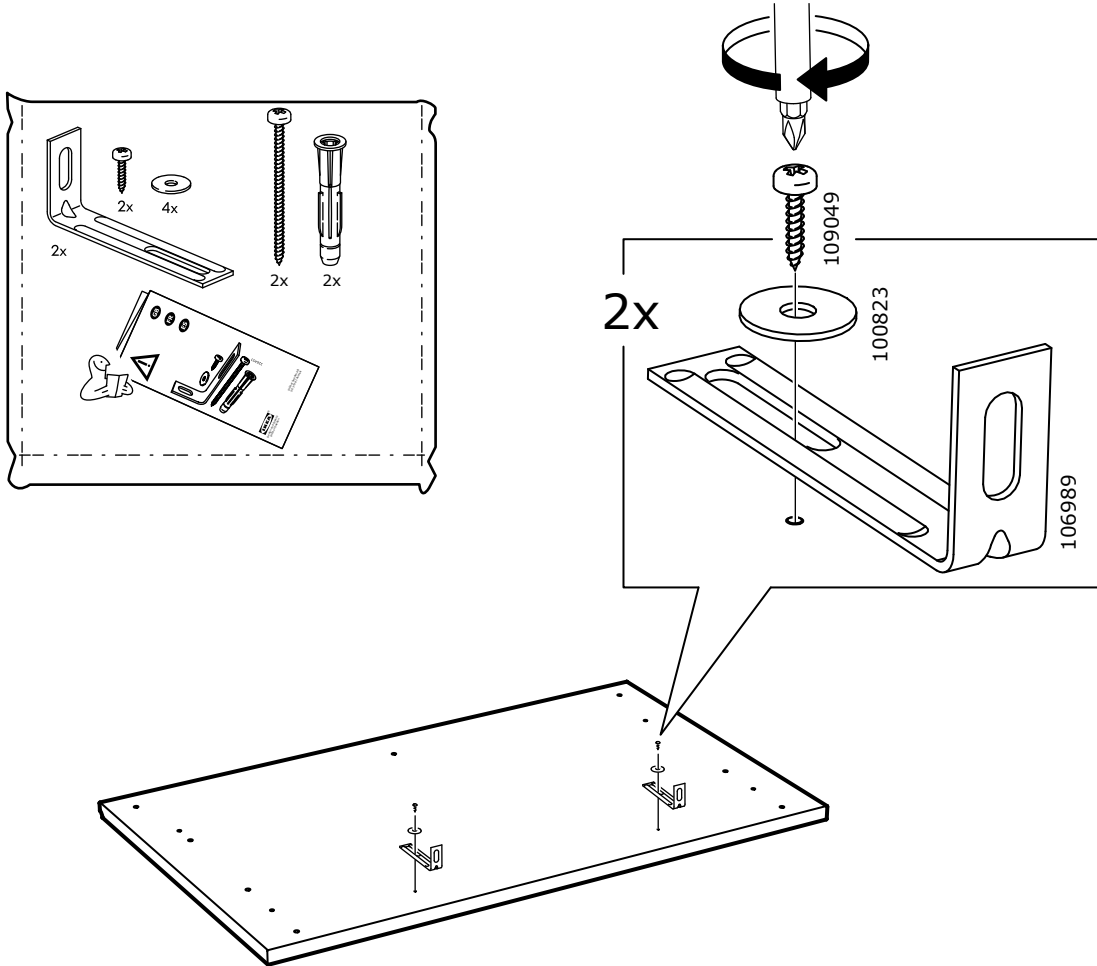

18

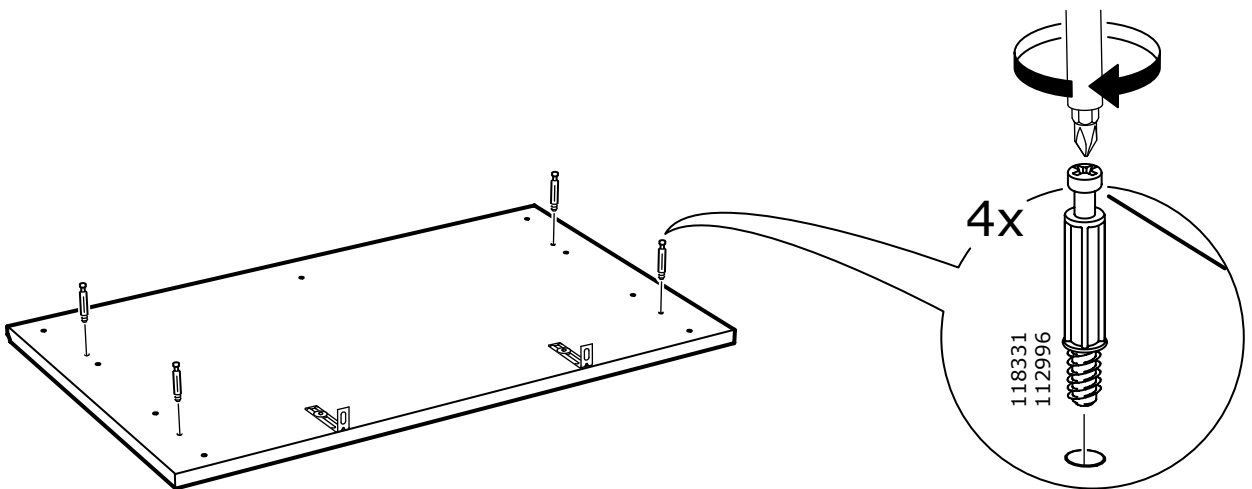

19

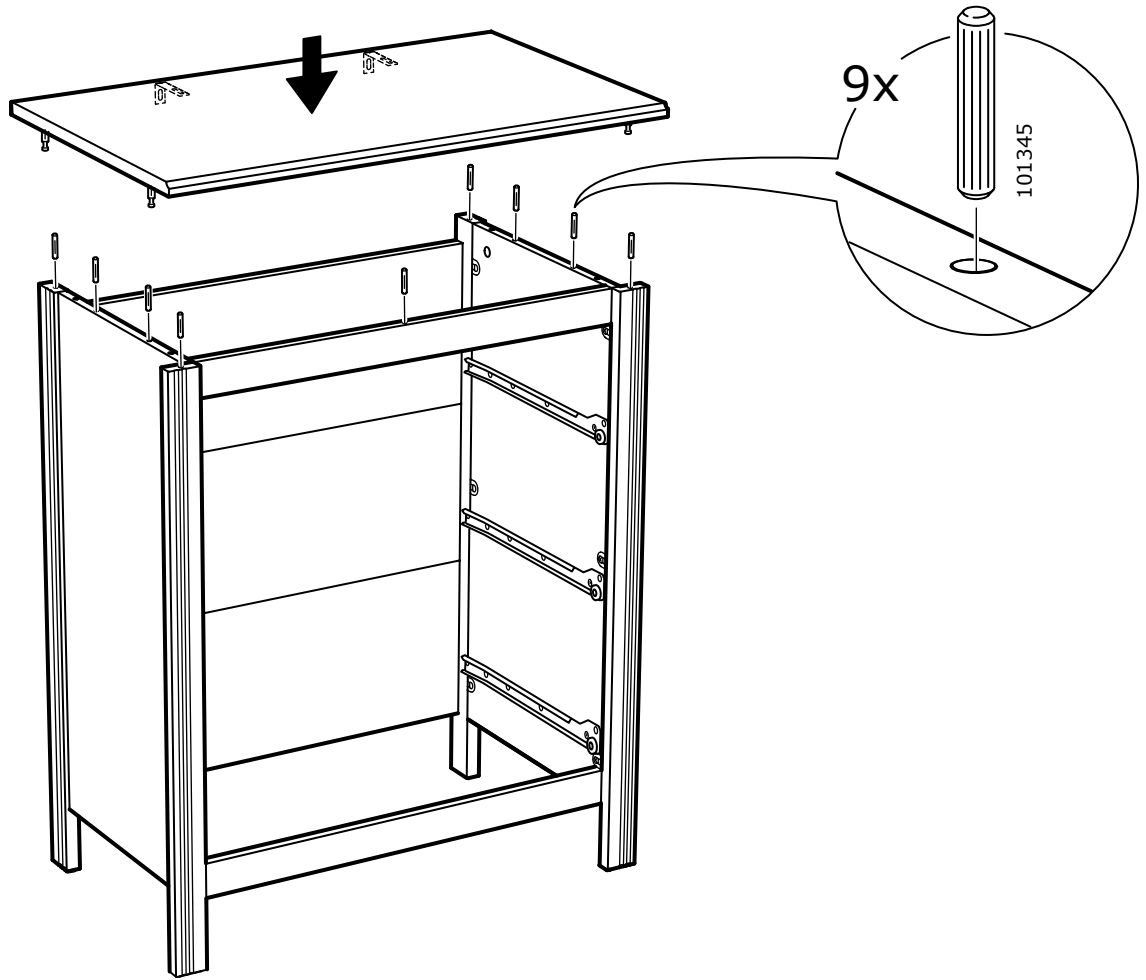

20

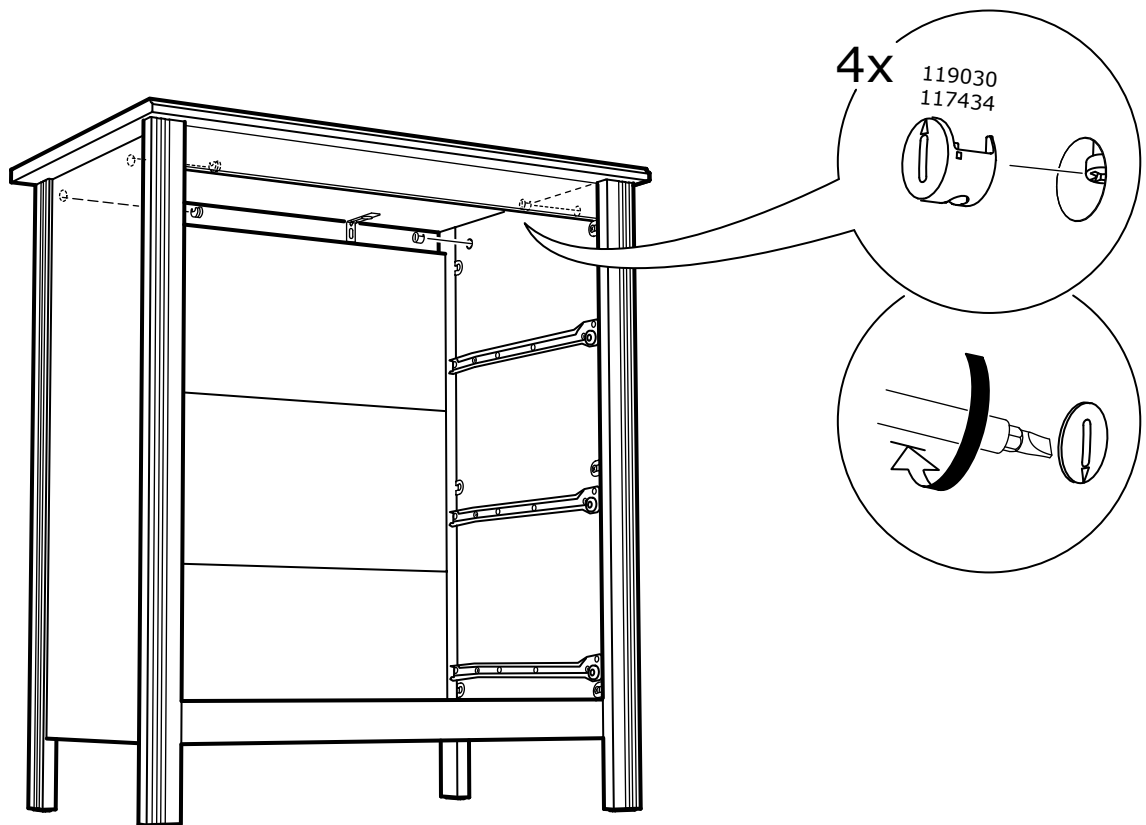

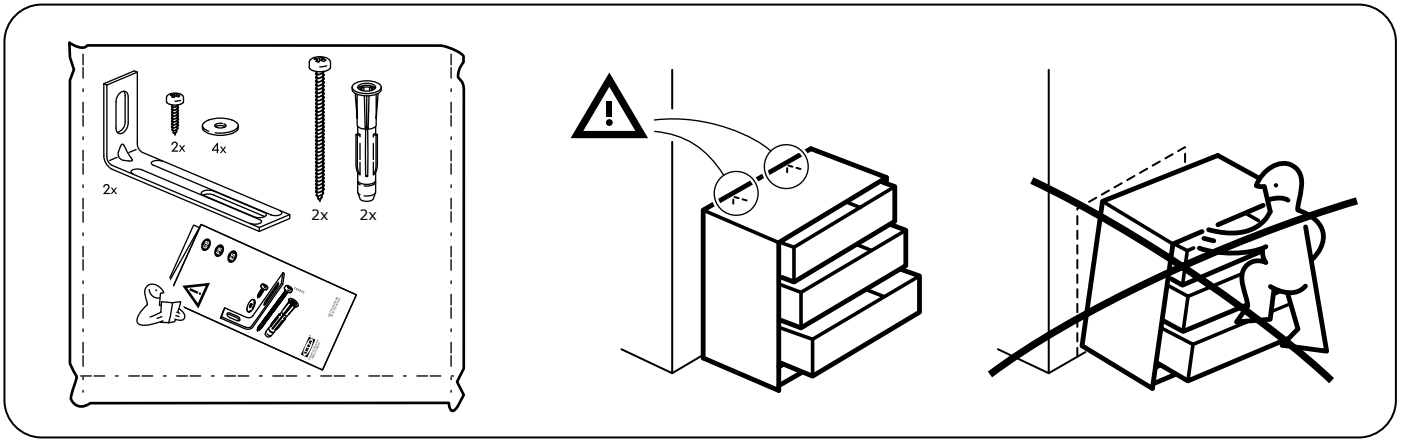

ENGLISH

WALL ANCHORING GUIDE:

The hardware you should use to secure your chest of drawers to the wall depends on both the type of chest of drawers you have and your wall material.

FRANÇAIS

INSTRUCTIONS POUR FIXATION AU MUR :

Le choix des fixations à utiliser pour fixer votre commode au mur dépend du type de commode et du matériau du mur.

ESPAÑOL

INSTRUCCIONES PARA EL MONTAJE A LA PARED:

Elige los accesorios necesarios para fijar la cajonera a la pared en función del tipo de mueble y del material del que esté hecha la pared.

21

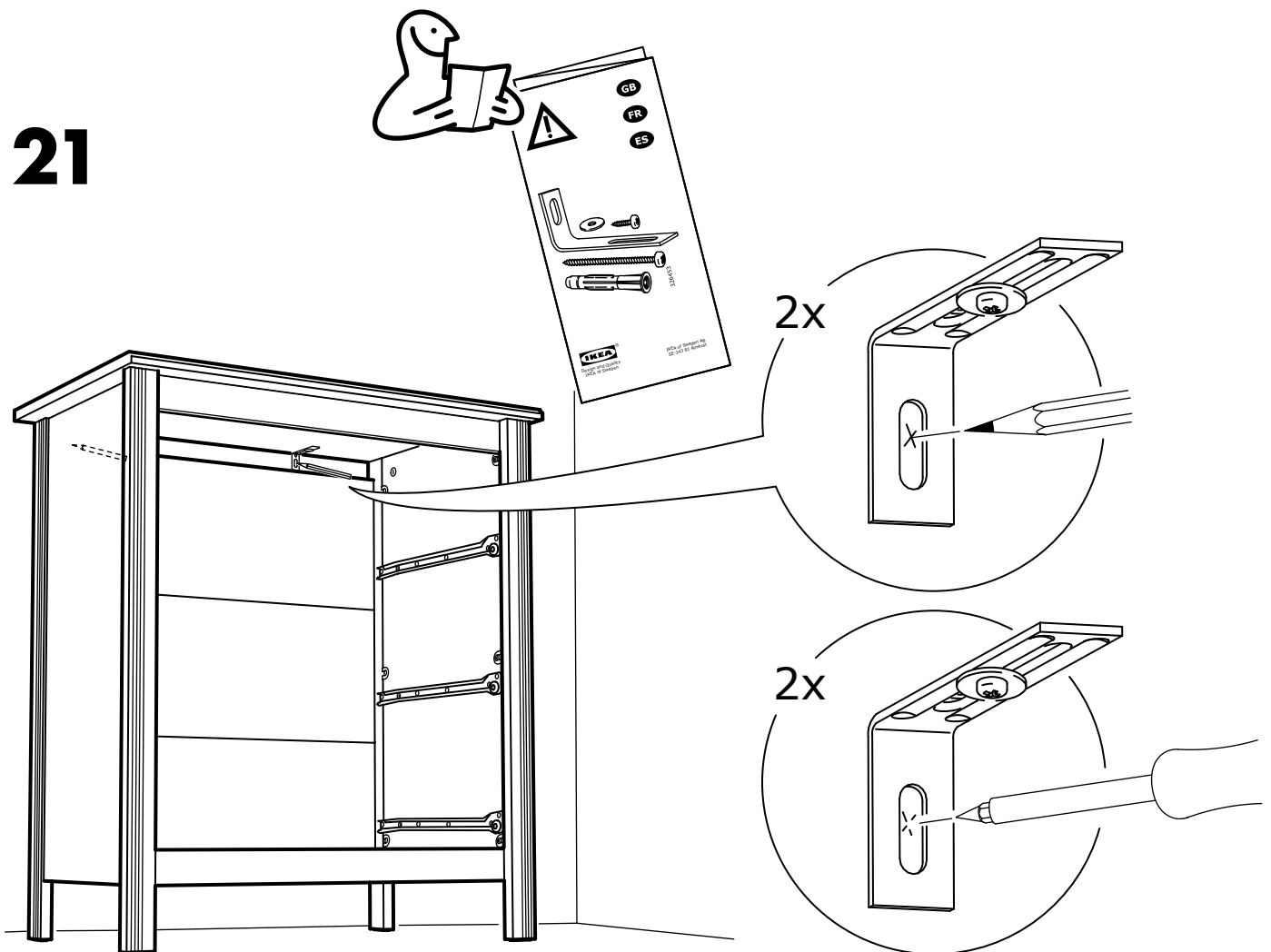

ENGLISH

Type of Wall Material: Using the guide below, identify your wall material and the appropriate steps to take for that wall material.

Drywall or plaster with available wood stud:

- Mark the attachment point(s) with a pencil at the appropriate height and positioned over wood stud(s).
- Drill 1/8-inch (3mm) diameter pilot hole(s) into the wood stud(s), at the height you marked with pencil.
- Following the appropriate pictogram instructions on the following pages, drive the screw(s) with washer(s) through the brackets and tighten screw(s) firmly into the wood.

Drywall without available wood stud:

- Mark the attachment point(s) with a pencil at the appropriate height.
- Drill 5/16-inch (8mm) diameter hole(s) through the wall at the height you marked with pencil.
- Drive the plastic plug(s) into the hole(s), using a hammer if needed.
- Following the appropriate pictogram instructions on the following pages, drive the screw(s) with washer(s) through the brackets and tighten screw(s) firmly into the plastic plug(s) in the wall. Do not over-tighten.

Masonry:

- Mark the attachment point(s) with a pencil at the appropriate height.
- Drill 5/16-inch (8mm) diameter hole(s) 2 and 3/4-inches (70mm) deep into the wall at the height you marked with pencil.
- Drive the plastic plug(s) into the hole(s), using a hammer if needed.
- Following the appropriate pictogram instructions on the following pages, drive the screw(s) with washer(s) through the brackets and tighten screw(s) firmly into the plastic plug(s) in the wall. Do not over-tighten.

If your wall material is not listed here, or if you have any questions, consult your local hardware store.

FRANÇAIS

Matériau du mur : le guide ci-dessous vous permet d'identifier le matériau de votre mur pour savoir comment procéder.

Cloison en plâtre avec montants en bois :

- Marquer le(s) point(s) de fixation à l'aide d'un crayon à la hauteur désirée sur le mur, en le(s) alignant sur le montant.
- Percer un(des) trou(s) pilote(s) de 3 mm (1/8 inch) de diamètre dans le(s) montant(s) en bois, à la hauteur marquée au crayon.
- Suivre les instructions correspondantes sous forme de pictogrammes figurant sur les pages suivantes et insérer la(les) vis avec la(les) rondelle(s) à travers les crochets, puis serrer fermement la(les) vis dans le montant en bois.

Cloison en plâtre sans montant en bois :

- Marquer le(s) point(s) de fixation à l'aide d'un crayon à la hauteur désirée.
- Percer dans le mur un(des) trou(s) de 8 mm (5/16 inch) de diamètre à la hauteur marquée au crayon.
- Insérer la(les) cheville(s) en plastique à l'intérieur du(des) trous. Utiliser un marteau si nécessaire.
- Suivre les instructions correspondantes sous forme de pictogrammes figurant sur les pages suivantes et insérer la(les) vis avec la(les) rondelle(s) à travers les crochets, puis serrer fermement la(les) vis dans la(les) cheville(s), dans le mur. Veiller à ne pas serrer de manière excessive.

Mur en maçonnerie :

- Marquer le(s) point(s) de fixation à l'aide d'un crayon à la hauteur désirée.
- Percer un trou de 8 mm (5/16") de diamètre et de 70 mm (2 3/4") de profondeur dans le mur à la hauteur marquée au crayon.
- Insérer la(les) cheville(s) en plastique à l'intérieur du(des) trous. Utiliser un marteau si nécessaire.
- Suivre les instructions correspondantes sous forme de pictogrammes figurant sur les pages suivantes et insérer la(les) vis avec la(les) rondelles à travers les crochets, puis visser fermement dans la(les) cheville(s) en plastique, dans le mur. Veiller à ne pas serrer de manière excessive.

Si le matériau de votre mur ne figure pas dans la liste ci-dessus, ou si vous avez des questions, adressez-vous à votre fournisseur local.

ESPAÑOL

Material de la pared: consulta la guía que figura a continuación para identificar de qué material está hecha la pared y saber qué pasos seguir.

Pared de pladur con posibilidad de montaje a la estructura de madera:

- Con un lápiz, marca el punto (o los puntos) de montaje a la altura adecuada de manera que coincidan con los listones de madera de la estructura interna del pladur.
- Con un taladro, haz un agujero de 3 mm (1/8") de diámetro en los listones de madera, justo encima de cada marca hecha con el lápiz.
- Siguiendo las instrucciones que se dan en las siguientes páginas, introduce los tornillos con su correspondiente arandela en los soportes y apriétalos bien a la madera.

Pladur sin posibilidad de montaje a la estructura de madera:

- Con un lápiz, marca el punto (o los puntos) de montaje a la altura adecuada.
- Con un taladro, haz un agujero de 8 mm (5/16") de diámetro en la pared, justo encima de cada marca de lápiz.
- Introduce los tacos de plástico en los agujeros con la ayuda, si fuera necesaria, de un martillo.
- Siguiendo las instrucciones que se dan en las siguientes páginas, introduce los tornillos con su correspondiente arandela en los soportes y apriétalos bien, pero sin pasarte, a los tacos de la pared.

Paredes de albañilería:

- Con un lápiz, marca el punto (o los puntos) de montaje a la altura adecuada.
- Con un taladro, haz un agujero de 8 mm (5/16") de diámetro y 70 mm de profundidad (2 3/4") en la pared, justo encima de cada marca de lápiz.
- Introduce los tacos de plástico en los agujeros con la ayuda, si fuera necesaria, de un martillo.
- Siguiendo las instrucciones que se dan en las siguientes páginas, introduce los tornillos con su correspondiente arandela en los soportes y apriétalos bien, pero sin pasarte, a los tacos de la pared.

Si el material de la pared no figura aquí o si tienes alguna duda, dirígete a una ferretería cercana.

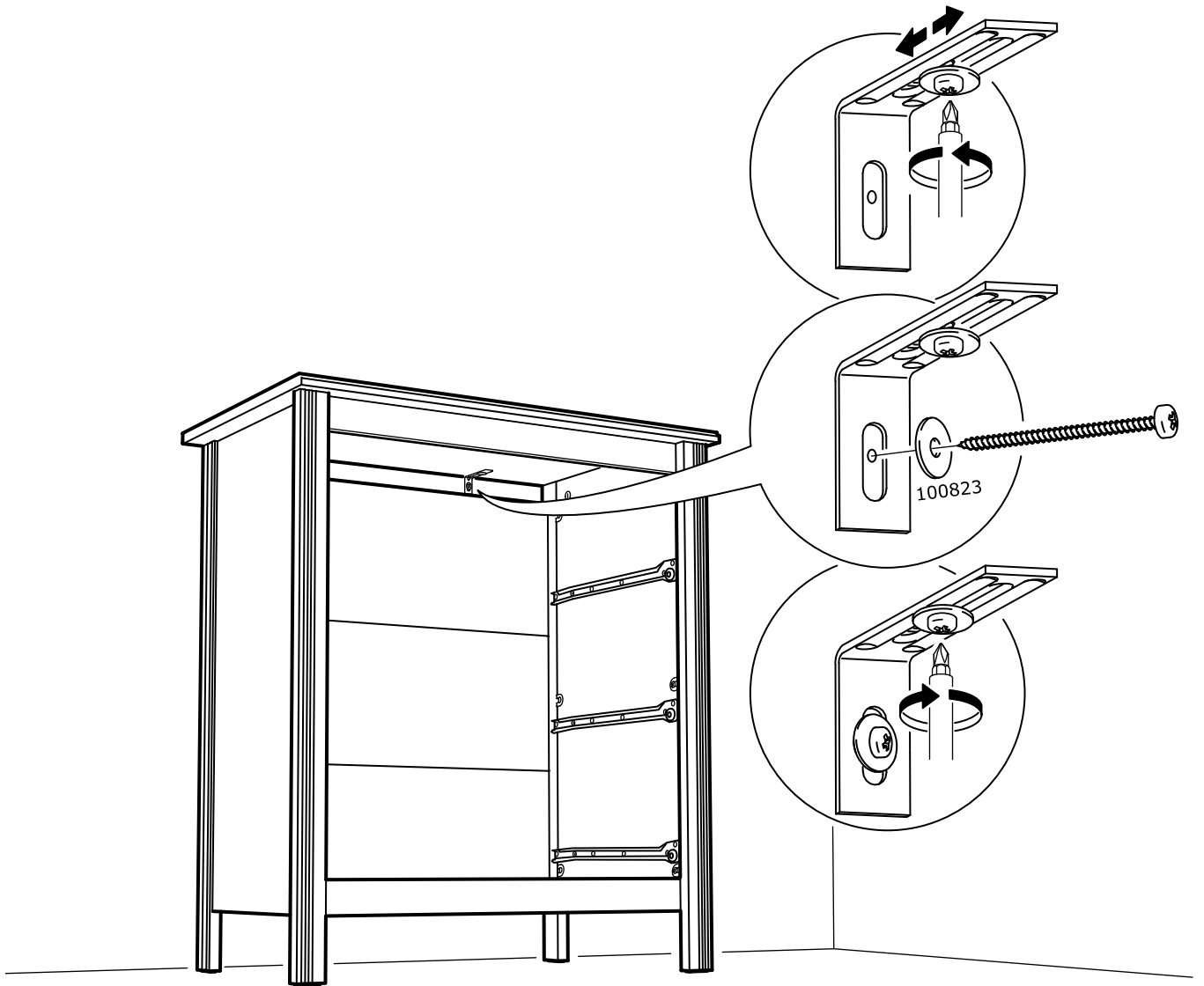

23

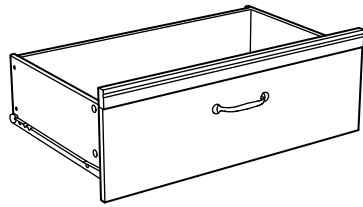

3x

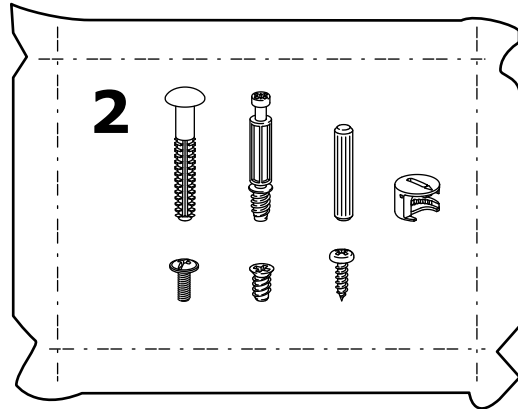

2

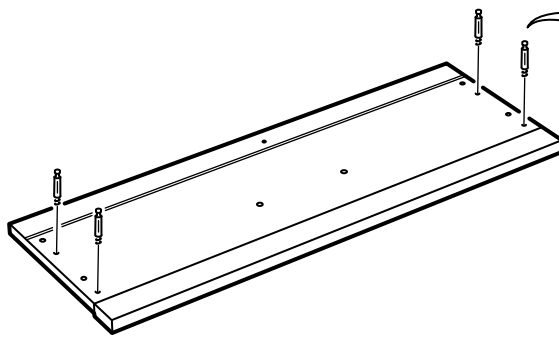
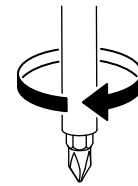

4x

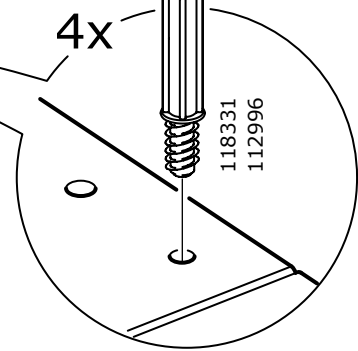

118331
112996

24

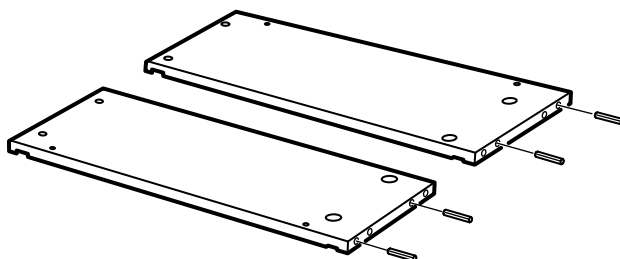

4x

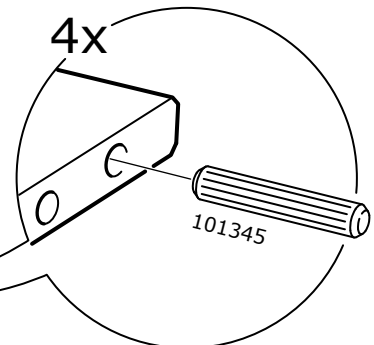

101345

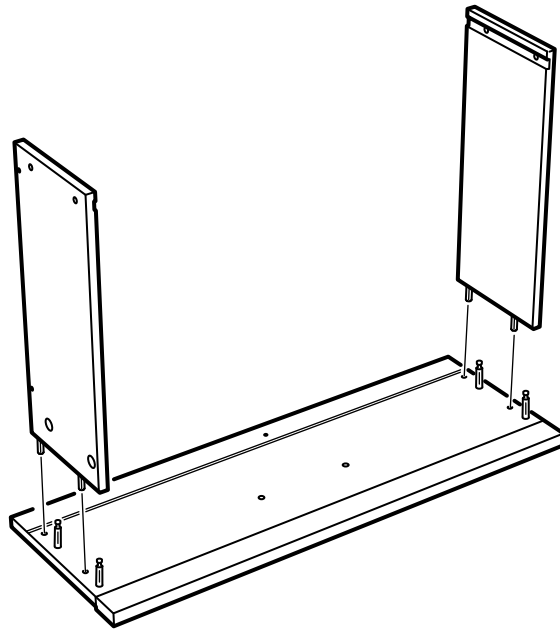

25

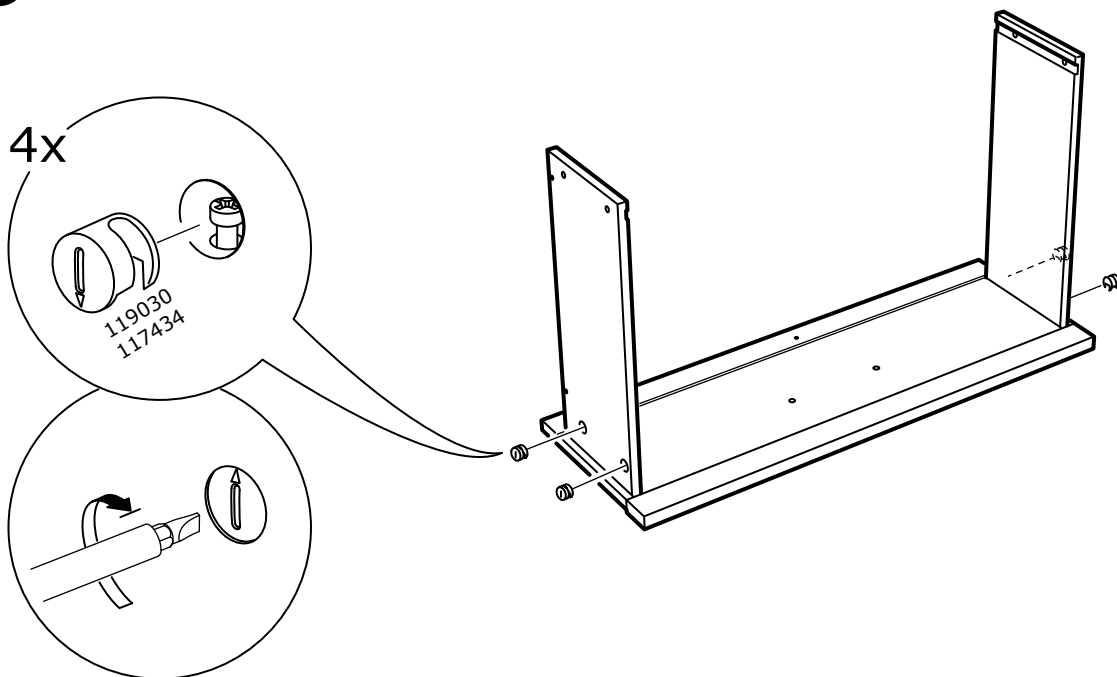

26



27

 WARNING	 ATTENTION	 ATENCIÓN
<p>ENGLISH Serious or fatal crushing injuries can occur from tipping furniture.</p> <p>To help prevent tip-over: ALWAYS secure this furniture to the wall using tip-over restraints.</p> <p>See product instructions for more ways to help prevent furniture tip-over.</p>	<p>FRANÇAIS Risque de blessures graves ou mortelles en cas de basculement du meuble.</p> <p>Pour éviter tout risque de basculement : TOUJOURS fixer ce meuble au mur à l'aide des fixations anti-basculement.</p> <p>Se reporter aux instructions relatives au produit pour connaître d'autres façons d'éviter le basculement du meuble.</p>	<p>ESPAÑOL Pueden ocurrir lesiones graves o fatales si se vuelcan los muebles.</p> <p>Para evitar vuelcos: Fija SIEMPRE este mueble a la pared con los dispositivos antivuelco.</p> <p>Mira las instrucciones del producto para ver aún más maneras de evitar que los muebles se vuelquen.</p>

1x

© Inter IKEA Systems B.V. 2009

AA-1794244-3

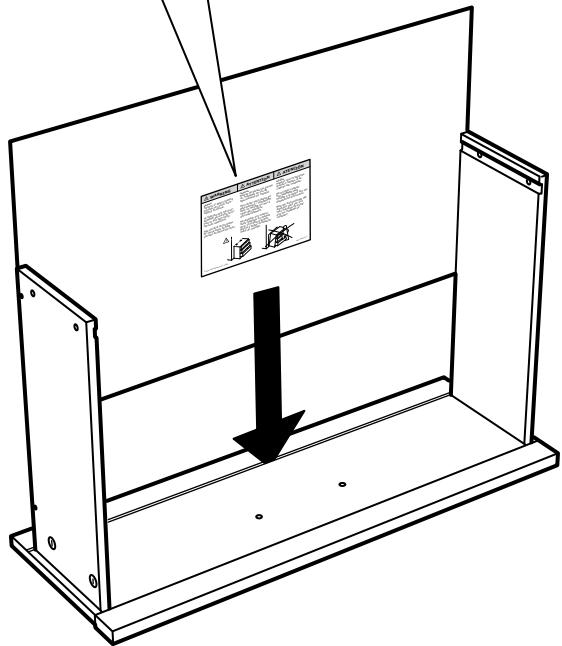

28

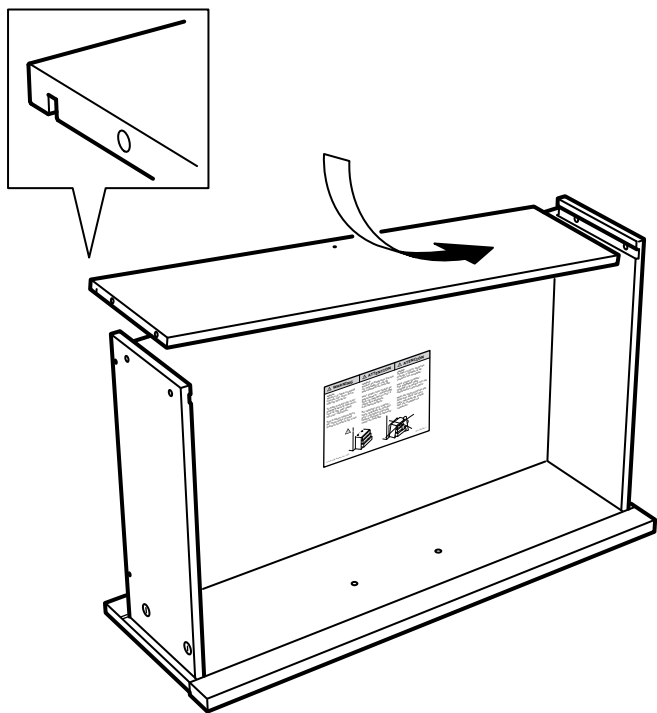

29

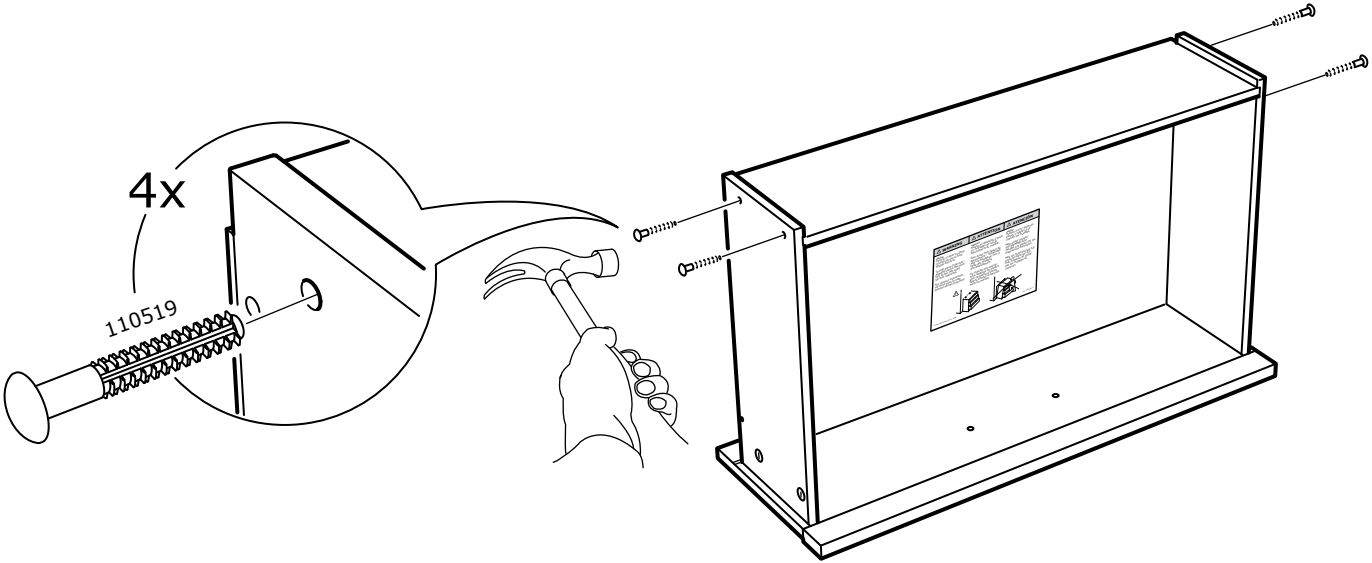

30

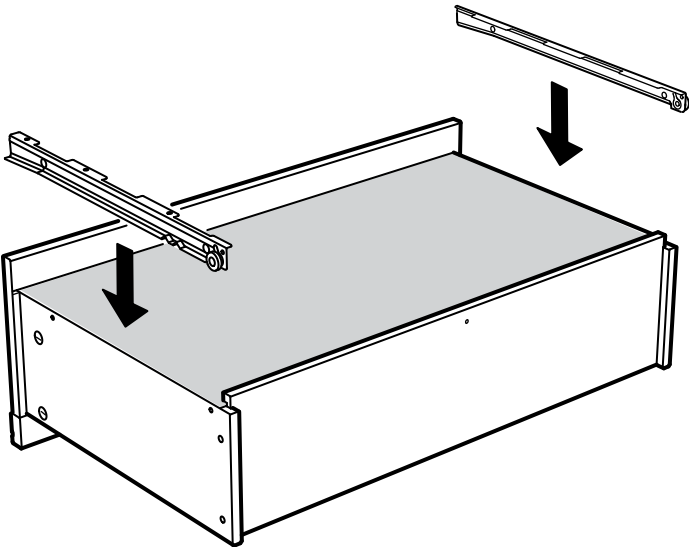
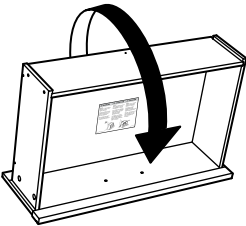

31

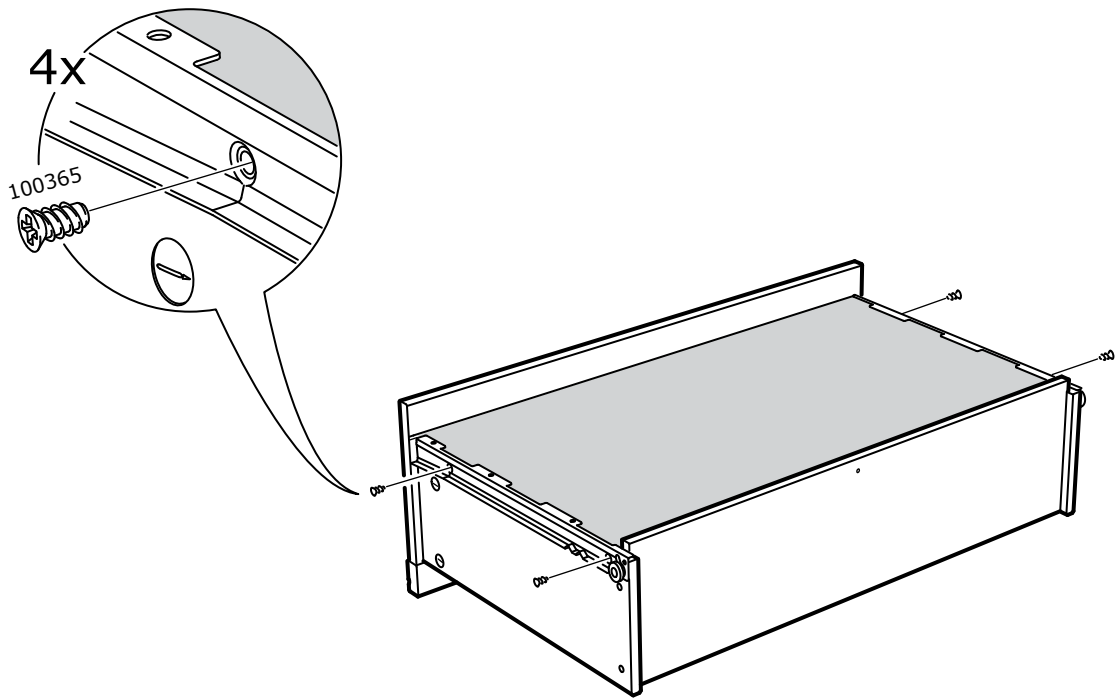

32

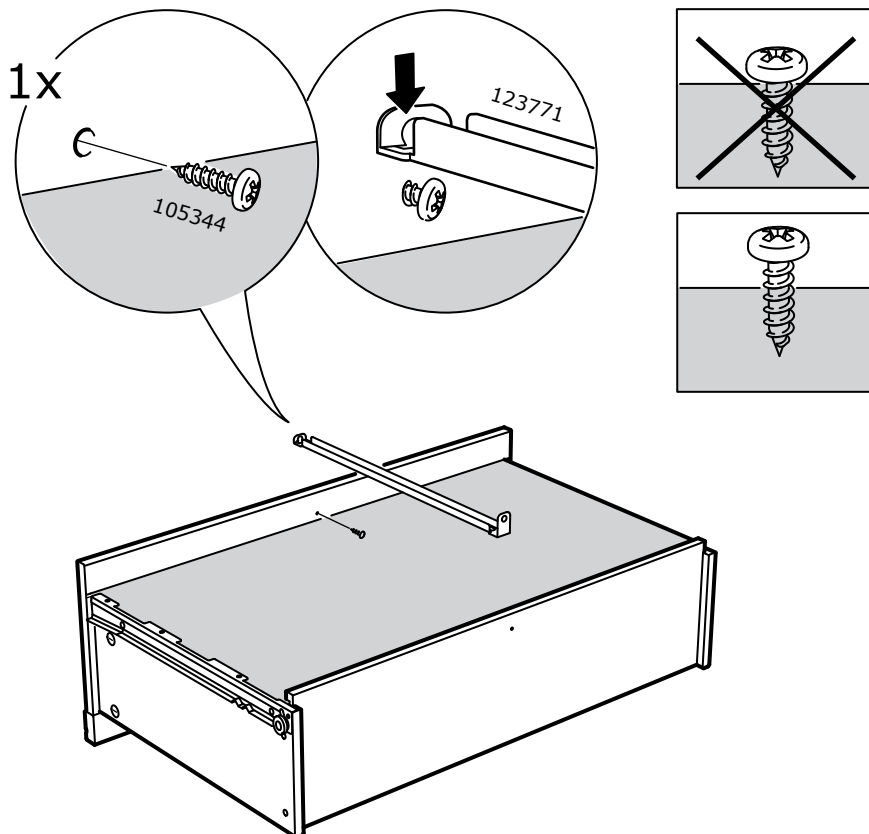

33

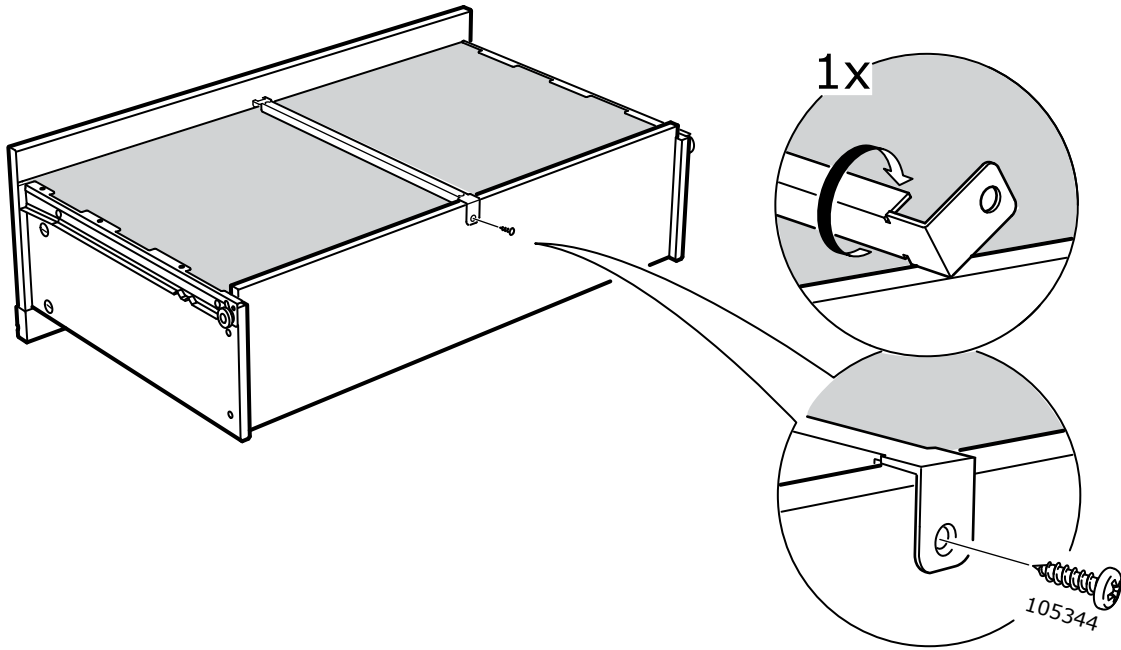

34

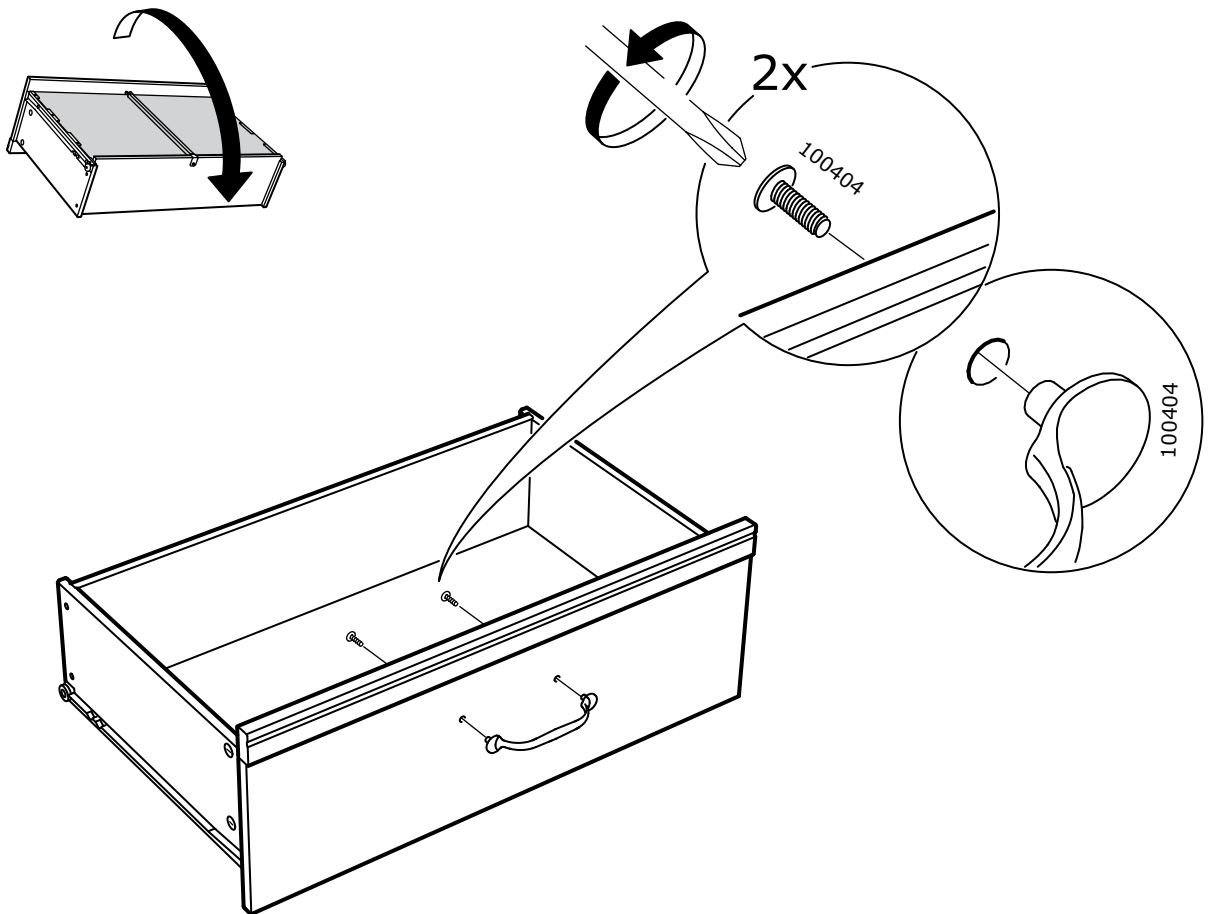

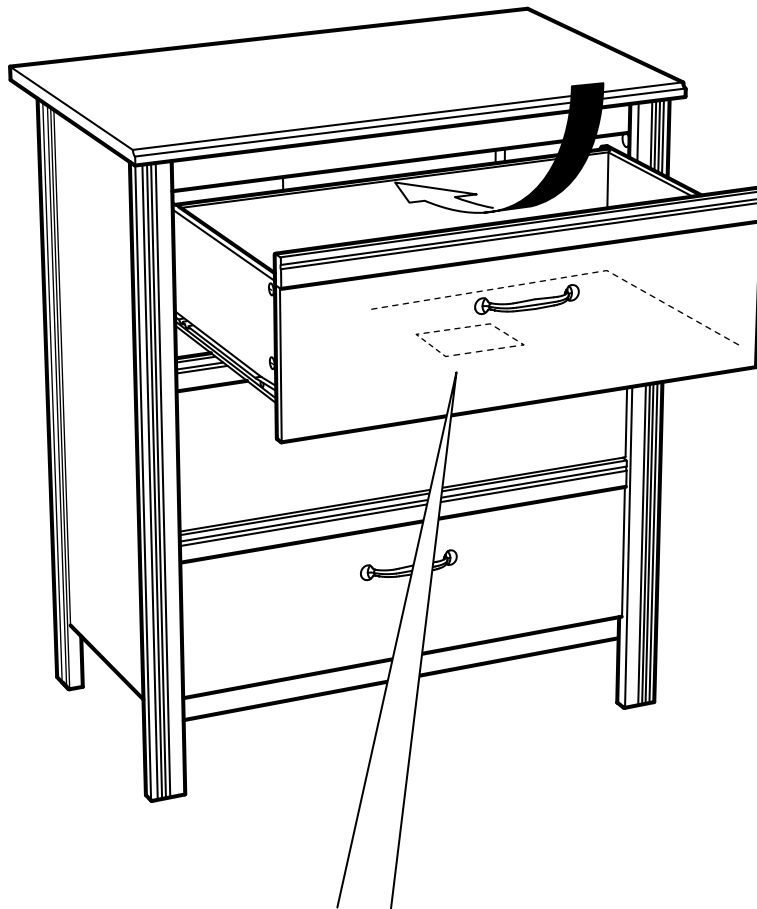

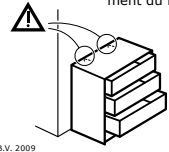
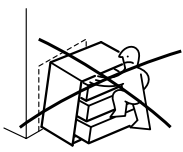
⚠ WARNING	⚠ ATTENTION	⚠ ATENCIÓN
<p>ENGLISH Serious or fatal crushing injuries can occur from tipping furniture.</p> <p>To help prevent tip-over: ALWAYS secure this furniture to the wall using tip-over restraints.</p> <p>See product instructions for more ways to help prevent furniture tip-over.</p>	<p>FRANÇAIS Risque de blessures graves ou mortelles en cas de basculement du meuble.</p> <p>Pour éviter tout risque de basculement : TOUJOURS fixer ce meuble au mur à l'aide des fixations anti-basculement.</p> <p>Se reporter aux instructions relatives au produit pour connaître d'autres façons d'éviter le basculement du meuble.</p>	<p>ESPAÑOL Pueden ocurrir lesiones graves o fatales si se vuelcan los muebles.</p> <p>Para evitar vuelcos: Fija SIEMPRE este mueble a la pared con los dispositivos antivuelco.</p> <p>Mira las instrucciones del producto para ver aún más maneras de evitar que los muebles se vuelquen.</p>
		
<small>© Inter IKEA Systems B.V. 2009</small>		<small>AA-1794244-3</small>

