

DJUPFRYSA



Design and Quality
IKEA of Sweden



ENGLISH

Please refer to the last page of this manual for the full list of IKEA appointed After Sales Service Provider and relative national phone numbers.

ENGLISH

4

Contents

| | | | |
|---------------------|----|------------------------|----|
| Safety information | 4 | Hints and tips | 12 |
| Safety instructions | 5 | Care and cleaning | 13 |
| Installation | 7 | Troubleshooting | 14 |
| Product description | 9 | Technical data | 17 |
| Operation | 9 | ENVIRONMENTAL CONCERNS | 18 |
| Daily use | 10 | IKEA GUARANTEE | 18 |

Subject to change without notice.

Safety information

Before the installation and use of the appliance, carefully read the supplied instructions. The manufacturer is not responsible for any injuries or damages that are the result of incorrect installation or usage. Always keep the instructions in a safe and accessible location for future reference.

Children and vulnerable people safety

- This appliance can be used by children aged 8 years and above and by persons with reduced capabilities provided that they have been given instruction and/or supervision regarding the safe use of the appliance and understand the potential hazards involved.
- Do not let children play with the appliance.
- Children shall not carry out cleaning and user maintenance of the appliance without supervision.
- Keep all packaging away from children and dispose of it appropriately.

General Safety

- This appliance is intended to be used in household and similar applications such as:
 - Farm houses; staff kitchen areas in shops, offices and other working environments

- By clients in hotels, motels, bed and breakfast and other residential type environments
- Keep ventilation openings, in the appliance enclosure or in the built-in structure, clear of obstruction.
- Do not use mechanical devices or other means to accelerate the defrosting process, other than those recommended by the manufacturer.
- Do not damage the refrigerant circuit.
- Do not use electrical appliances inside the food storage compartments of the appliance, unless they are of the type recommended by the manufacturer.
- Do not use water spray and steam to clean the appliance.
- Clean the appliance with a moist soft cloth. Only use neutral detergents. Do not use abrasive products, abrasive cleaning pads, solvents or metal objects.
- Do not store explosive substances such as aerosol cans with a flammable propellant in this appliance.
- If the supply cord is damaged, it must be replaced by the manufacturer, its Authorised Service Centre or similarly qualified persons in order to avoid a hazard.

Safety instructions

Installation



Warning! Only a qualified person must install this appliance.

- Remove all the packaging and the transit bolts.
- Do not install or use a damaged appliance.
- Follow the installation instruction supplied with the appliance.
- Always take care when moving the appliance as it is heavy. Always use safety gloves and enclosed footwear.
- Make sure the air can circulate around the appliance.
- Wait at least 4 hours before connecting the appliance to the power supply. This is to allow the oil to flow back in the compressor.
- Do not install the appliance close to radiators or cookers, oven or hobs.
- The rear of the appliance must stand against the wall.
- Do not install the appliance where there is direct sunlight.
- Do not install this appliance in areas that are too humid or too colds, such as the construction appendices, garages or wine cellars.
- When you move the appliance, lift it by the front edge to avoid scratching the floor.

Electrical connection

 **Warning!** Risk of fire and electrical shock.

- The appliance must be earthed.
- Make sure that the electrical information on the rating plate agrees with the power supply. If not, contact an electrician.
- Always use a correctly installed shockproof socket.
- Do not use multi-plug adapters and extension cables.
- Make sure not to cause damage to the electrical components (e.g. mains plug, mains cable, compressor). Contact the Authorised Service Centre or an electrician to change the electrical components.
- The mains cable must stay below the level of the mains plug.
- Connect the mains plug to the mains socket only at the end of the installation. Make sure that there is access to the mains plug after the installation.
- Do not pull the mains cable to disconnect the appliance. Always pull the mains plug.

Use

 **Warning!** Risk of injury, burns, electrical shock or fire.

- Do not change the specification of this appliance.
- Do not put electrical appliances (e.g. ice cream makers) in the appliance unless they are stated applicable by the manufacturer.
- Be careful not to cause damage to the refrigerant circuit. It contains isobutane (R600a), a natural gas with a high level of environmental compatibility. This gas is flammable.
- If damage occurs to the refrigerant circuit, make sure that there are no

flames and sources of ignition in the room. Ventilate the room.

- Do not let hot items to touch the plastic parts of the appliance.
- Do not put soft drinks in the freezer compartment. This will create pressure on the drink container.
- Do not store flammable gas and liquid in the appliance.
- Do not put flammable products or items that are wet with flammable products in, near or on the appliance.
- Do not touch the compressor or the condenser. They are hot.
- Do not remove or touch items from the freezer compartment if your hands are wet or damp.
- Do not freeze again food that has been thawed.
- Obey the storage instructions on the packaging of frozen food.

Care and cleaning

 **Warning!** Risk of injury or damage to the appliance.

- Before maintenance, deactivate the appliance and disconnect the mains plug from the mains socket.
- This appliance contains hydrocarbons in the cooling unit. Only a qualified person must do the maintenance and the recharging of the unit.
- Regularly examine the drain of the appliance and if necessary, clean it. If the drain is blocked, defrosted water collects in the bottom of the appliance.

Disposal

 **Warning!** Risk of injury or suffocation.

- Disconnect the appliance from the mains supply.
- Cut off the mains cable and discard it.
- Remove the door to prevent children and pets to be closed inside of the appliance.

- The refrigerant circuit and the insulation materials of this appliance are ozone-friendly.
- The insulation foam contains flammable gas. Contact your municipal authority for information on how to discard the appliance correctly.
- Do not cause damage to the part of the cooling unit that is near the heat exchanger.

Installation

 **Warning!** Refer to Safety chapters.

Location

 Refer to the assembly instructions for the installation.

To ensure best performance, install the appliance well away from sources of heat such as radiators, boilers, direct sunlight etc. Make sure that air can circulate freely around the back of the cabinet.

Positioning

This appliance should be installed in a dry, well ventilated indoor (garage or cellar) also, but for optimum performance install this appliance at a location where the ambient temperature corresponds to the climate class indicated on the rating plate of the appliance:

| Climate class | Ambient temperature |
|---------------|---------------------|
| SN | +10°C to + 32°C |
| N | +16°C to + 32°C |
| ST | +16°C to + 38°C |
| T | +16°C to + 43°C |

Electrical Connection

 **Caution!** Any electrical work required to install this appliance should be carried out by a qualified electrician or competent person.

 **Warning!** This appliance must be earthed. The manufacturer declines any liability should these safety measures not be observed.

The wires in the mains lead are coloured in accordance with the following code:

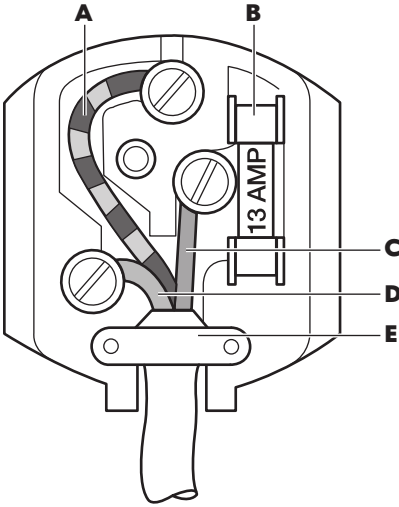

- **A** - green and yellow: Earth
- **C** - brown: Live
- **D** - blue: Neutral

As the colours of the wires in the mains lead of this appliance may not correspond with the coloured markings identifying the terminals in your plug, proceed as follows:

1. Connect the wire coloured green and yellow to the terminal marked either with the letter "E" or by the earth symbol \oplus or coloured green and yellow.
2. Connect the wire coloured blue to the terminal either marked with the letter "N" or coloured black.
3. Connect the wire coloured brown to the terminal either marked with the "L" or coloured red.
4. Check that no cut, or stray strands of wire is present and the cord clamp (E) is secure over the outer sheath.
Make sure the electricity supply voltage is the same as that indicated on the appliance rating plate.
5. Switch on the appliance.

The appliance is supplied with a 13 amp fuse (B). In the event of having to change the fuse in the plug supplied, a 13 amp ASTA approved (BS 1362) fuse must be used.



Warning! A cut off plug inserted into a 13 amp socket is a serious safety (shock) hazard. Ensure that it is disposed of safely.

Product description

Product overview

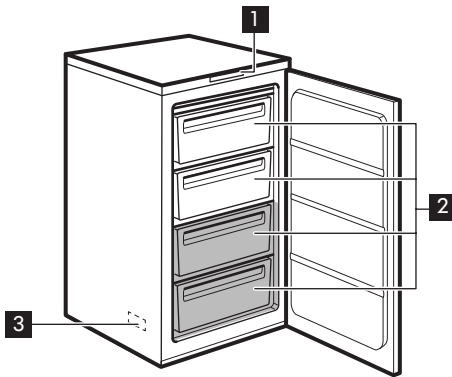

- 1** Control panel
- 2** Freezer drawers
- 3** Rating plate (situated inside of the appliance)
- Coldest zone

Operation

Control panel

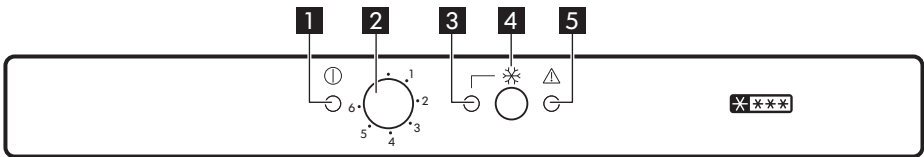

- 1** Pilot light
- 2** Temperature regulator
- 3** Fast Freezing light
- 4** Fast Freezing switch/Alarm reset switch
- 5** Alarm light

Switching on

Insert the plug into the wall socket. The pilot light will light up and you will hear the buzzer.

- i** If the temperature inside the appliance is too high the Alarm light will blink. Active the Fast Freezing function.

Switching off

To turn off the appliance, turn the Temperature regulator to the "0" position. The pilot light will switch off and you will hear the buzzer.

Temperature regulation

The temperature is regulated automatically.

-  A medium setting is generally the most suitable.

However, the exact setting should be chosen keeping in mind that the temperature inside the appliance depends on:

- room temperature,
- how often the door is opened,
- the quantity of food stored,
- the location of the appliance.

1. Turn the Temperature regulator toward lower settings to obtain the minimum coldness.
2. Turn the Temperature regulator toward higher settings to obtain the maximum coldness.

-  **Caution!** If the ambient temperature is high or the appliance is fully loaded, and the appliance is set to the lowest temperatures, it may run continuously causing frost to form on the rear wall. In this case the dial must be set to a higher temperature to allow automatic defrosting and therefore reduced energy consumption.

Fast Freezing function

1. Press the Fast Freezing switch to activate the Fast Freezing function.

The Fast Freezing light will light up.

2. Press the Fast Freezing switch to deactivate the function at any time.

The Fast Freezing light will switch off.

-  This function stops automatically after 52 hours.

Acoustic alarm

An acoustic alarm will sound when the temperature inside the freezer has risen to a point where the safe storage of frozen food is no longer ensured.

When normal conditions are restored, the acoustic alarm will stop.

-  In any case, press the Alarm reset switch to deactivate the acoustic alarm.

Door open alarm

An acoustic alarm will sound when the door is left open for around 80 seconds.

When normal conditions are restored (door closed), the acoustic alarm will stop.

In any case, press the Alarm reset switch to deactivate the acoustic alarm.

Daily use

-  **Warning!** Refer to Safety chapters.

Freezing Calendar

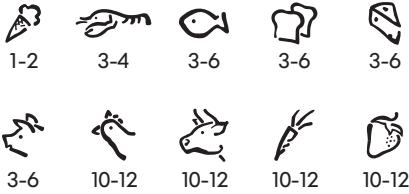

The symbols show different types of frozen goods.

The numbers indicate storage times in months for the appropriate types of frozen goods. Whether the upper or lower value of the indicated storage time is valid depends on the quality of the foods and treating before freezing.

Accessories

Ice tray

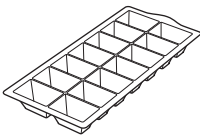

x1

Ice scraper

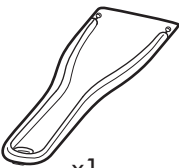

x1

Freezing fresh food

The freezer compartment is suitable for freezing fresh food and storing frozen and deep-frozen food for a long time.

To freeze fresh food activate the Fast Freezing function at least 24 hours before placing the food to be frozen in the freezer compartment.

Place the fresh food to be frozen in the two bottom compartments.

The maximum amount of food that can be frozen in 24 hours is specified on the rating plate, a label located on the side of the appliance.

The freezing process lasts 24 hours: during this period do not add other food to be frozen.

After 24 hours, when the freezing process is completed, deactivate the Fast Freezing function (see "Fast Freezing function").

Storage of frozen food

When first starting-up or after a period out of use, before putting the products in the compartment let the appliance run at least 12 hours on the Fast Freezing setting.

If large quantities of food are to be stored, remove all drawers from appliance and place food on glass shelf to obtain the best performance.



In the event of accidental defrosting, for example due to a power failure, if the power has been off for longer than the value shown in the technical characteristics chart under "rising time", the defrosted food must be consumed quickly or cooked immediately and then re-frozen (after cooling).

Thawing

Deep-frozen or frozen food, prior to being used, can be thawed in the refrigerator compartment or at room temperature, depending on the time available for this operation.

Small pieces may even be cooked still frozen, directly from the freezer: in this case, cooking will take longer.

Ice-cube production

This appliance is equipped with one tray for the production of ice-cubes.

1. Fill the tray with water.
2. Put the tray in the freezer compartment



Caution! Do not use metallic instruments to remove the tray from the freezer.

Hints and tips

Normal operating sounds

The following sounds are normal during operation:

- A faint gurgling and bubbling sound from coils sound when refrigerant is pumped.
- A whirring and pulsating sound from the compressor when refrigerant is pumped.
- A sudden cracking noise from inside appliance caused by thermic dilatation (a natural and not dangerous physical phenomenon).
- A faint click noise from the temperature regulator when the compressor switches on or off.

Hints for energy saving

- Do not open the door frequently or leave it open longer than absolutely necessary.

Hints for freezing

To help you make the most of the freezing process, here are some important hints:

- the maximum quantity of food which can be frozen in 24 hours is shown on the rating plate;
- the freezing process takes 24 hours no further food to be frozen should be added during this period;
- freeze only top quality, fresh and thoroughly cleaned, foodstuffs;

- prepare food in small portions to enable it to be rapidly and completely frozen and to make it possible subsequently to thaw only the quantity required;
- wrap up the food in aluminium foil or polythene and make sure that the packages are airtight;
- do not allow fresh, unfrozen food to touch food which is already frozen, thus avoiding a rise in temperature of the latter;
- lean foods store better and longer than fatty ones; salt reduces the storage life of food;
- water ices, if consumed immediately after removal from the freezer compartment, can possibly cause the skin to be freeze burnt;
- it is advisable to show the freezing in date on each individual pack to enable you to keep tab of the storage time.

Hints for storage of frozen food

To obtain the best performance from this appliance, you should:

- make sure that the commercially frozen foodstuffs were adequately stored by the retailer;
- be sure that frozen foodstuffs are transferred from the foodstore to the freezer in the shortest possible time;
- not open the door frequently or leave it open longer than absolutely necessary;

- once defrosted, food deteriorates rapidly and cannot be refrozen;
- do not exceed the storage period indicated by the food manufacturer.

Care and cleaning

 **Warning!** Refer to Safety chapters.

General warnings

 **Caution!** Unplug the appliance before carrying out any maintenance operation.

 This appliance contains hydrocarbons in its cooling unit; maintenance and recharging must therefore only be carried out by authorized technicians.

 The accessories and parts of the appliance are not suitable for washing in a dishwasher.

Cleaning the interior

1. Before using the appliance for the first time, wash the interior and all internal accessories with lukewarm water and some neutral soap so as to remove the typical smell of a brand-new product.
 2. Dry thoroughly.
-  Do not use detergents or abrasive powders, as these will damage the finish.

Periodic cleaning

 **Caution!** Do not pull, move or damage any pipes and/or cables inside the cabinet.

 **Caution!** Take care of not to damage the cooling system.

 **Caution!** When moving the cabinet, lift it by the front edge to avoid scratching the floor.

The equipment has to be cleaned regularly:

1. Clean the inside and accessories with lukewarm water and some neutral soap.
2. Regularly check the door seals and wipe clean to ensure they are clean and free from debris.
3. Rinse and dry thoroughly.
4. If accessible, clean the condenser and the compressor at the back of the appliance with a brush. This operation will improve the performance of the appliance and save electricity consumption.

Defrosting the freezer

 **Caution!** Never use sharp metal tools to scrape off frost from the evaporator as you could damage it. Do not use a mechanical device or any artificial means to speed up the thawing process other than those recommended by the manufacturer. A temperature rise of the frozen food packs, during defrosting, may shorten their safe storage life.

 About 12 hours prior to defrosting, set a lower temperature, in order to build up sufficient chill reserve for the interruption in operation.

A certain amount of frost will always form on the freezer shelves and around the top compartment.

Defrost the freezer when the frost layer reaches a thickness of about 3-5 mm.

1. Switch off the appliance, or pull out the electrical plug from the wall socket.
2. Remove any stored food, wrap it in several layers of newspaper and put it in a cool place.

 **Warning!** Do not touch frozen food with wet hands. Hands can freeze to the goods.
3. Leave the door open and protect the floor from the defrosting water e.g. with a cloth.

In order to speed up the defrosting process, place a pot of warm water in the freezer compartment. In addition, remove pieces of ice with an ice scraper before defrosting is complete.
4. When defrosting is complete, dry the interior thoroughly and keep the scraper for future use.

5. Switch on the appliance. Wait at least 3 hours before putting the food back into the freezer compartment.

Periods of non-operation

When the appliance is not in use for long periods, take the following precautions:

1. Disconnect the appliance from electricity supply.
2. Remove all food.
3. Defrost (if necessary) and clean the appliance and all accessories.
4. Leave the door/doors open to prevent unpleasant smells.

 **Warning!** If you want to keep the appliance switched on, ask somebody to check it once in a while to prevent the food inside from spoiling in case of a power failure.

Troubleshooting

 **Warning!** Refer to Safety chapters.

What to do if...

| Problem | Possible cause | Solution |
|---------------------------------|--|--|
| The appliance does not operate. | The appliance is switched off. | Switch on the appliance. |
| The appliance does not operate. | The mains plug is not connected to the mains socket correctly. | Connect the mains plug to the mains socket correctly. |
| The appliance does not operate. | There is no voltage in the mains socket. | Connect a different electrical appliance to the mains socket. Contact a qualified electrician. |

| Problem | Possible cause | Solution |
|--------------------------------------|---|---|
| The appliance is noisy. | The appliance is not supported properly. | Check if the appliance stands stable. |
| Audible or visual alarm is on. | The cabinet has been recently switched on or the temperature is still too high. | Refer to "High Temperature Alarm". |
| Audible or visual alarm is on. | The temperature in the appliance is too high. | Contact a qualified electrician or contact the nearest Authorised Service Centre. |
| The compressor operates continually. | Temperature is set incorrectly. | Refer to "Operation" chapter. |
| The compressor operates continually. | Many food products were inserted at the same time. | Wait a few hours and then check the temperature again. |
| The compressor operates continually. | The room temperature is too high. | Refer to climate class chart on the rating plate. |
| The compressor operates continually. | Food products placed in the appliance were too warm. | Allow food products to cool to room temperature before storing. |
| The compressor operates continually. | The door is not closed correctly. | Refer to "Closing the door". |
| The compressor operates continually. | The Fast Freezing function is switched on. | Refer to "Fast Freezing function". |
| There is too much frost and ice. | The door is not closed correctly or the gasket is deformed/dirty. | Refer to "Closing the door". |
| There is too much frost and ice. | The water drainage plug is not correctly positioned. | Position the water drainage plug in the correct way. |
| There is too much frost and ice. | Food products are not wrapped properly. | Wrap the food products better. |
| There is too much frost and ice. | Temperature is set incorrectly. | Refer to "Operation" chapter. |

| Problem | Possible cause | Solution |
|---|--|--|
| The compressor does not start immediately after pressing Fast Freezing, or after the change of the temperature. | This is normal, no error has occurred. | The compressor starts after some time. |
| Temperature cannot be set. | The Fast Freezing function is switched on. | Switch off Fast Freezing function manually, or wait until the function resets automatically to set the temperature. Refer to "Fast Freezing function". |
| The temperature in the appliance is too low/too high. | The temperature regulator is not set correctly. | Set a higher/lower temperature. |
| The temperature in the appliance is too low/too high. | The food products temperature is too high. | Let the food products temperature decrease to room temperature before storage. |
| The temperature in the appliance is too low/too high. | The thickness of the frost is greater than 4-5 mm. | Defrost the appliance. |
| The temperature in the appliance is too low/too high. | The door has been opened too often. | Open the door only if necessary. |
| The temperature in the appliance is too low/too high. | The Fast Freezing function is switched on. | Refer to "Fast Freezing function". |
| The temperature in the appliance is too low/too high. | There is no cold air circulation in the appliance. | Make sure that there is cold air circulation in the appliance. |
| Door does not open easily. | You attempted to re-open the door immediately after closing. | Wait a few seconds between closing and re-opening of the door. |

i If your appliance is still not working properly after making the above checks, contact the Authorised Service Centre. You can find the list at the end of this manual.

2. If necessary, adjust the door. Refer to assembly instructions.
3. If necessary, replace the defective door gaskets. Contact the Authorised Service Centre.

Closing the door

1. Clean the door gaskets.

Technical data

Technical data

| | |
|---------------------------|---------------|
| Product category | |
| Appliance Type | Freezer |
| Installation Type | Built-in |
| Product dimensions | |
| Height | 873 mm |
| Width | 540 mm |
| Depth | 549 mm |
| Net volume | |
| Freezer | 98 Litre |
| Defrost system | |
| Freezer | manual |
| Star rating | ✱✱✱✱ |
| Rising time | 20 hours |
| Freezing capacity | 10 kg/24h |
| Energy consumption | 0,430 kWh/24h |
| Noise level | 34 dB (A) |
| Energy class | A++ |
| Voltage | 230 - 240 V |
| Frequency | 50 Hz |

The technical information is situated in the rating plate on the internal left side of the appliance and in the energy label.

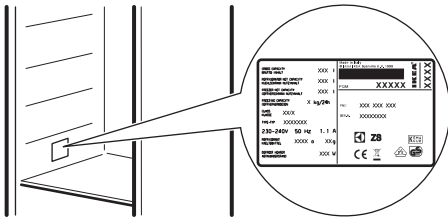

ENVIRONMENTAL CONCERNS

Recycle the materials with the symbol . Put the packaging in applicable containers to recycle it. Help protect the environment and human health and to recycle waste of electrical and electronic appliances. Do not

dispose appliances marked with the symbol  with the household waste. Return the product to your local recycling facility or contact your municipal office.

IKEA GUARANTEE

How long is the IKEA guarantee valid?

This guarantee is valid for five (5) years from the original date of purchase of Your appliance at IKEA, unless the appliance is named LAGAN in which case two (2) years of guarantee apply. The original sales receipt is required as proof of purchase. If service work is carried out under guarantee, this will not extend the guarantee period for the appliance,

Which appliances are not covered by the IKEA five (5) years guarantee?

The range of appliances named LAGAN and all appliances purchased in IKEA before 1st of August 2007

Who will execute the service?

IKEA service provider will provide the service through its own service operations or authorized service partner network.

What does this guarantee cover?

The guarantee covers faults of the appliance, which have been caused by faulty construction or material faults from the date of purchase from IKEA. This guarantee applies to domestic use only. The exceptions are specified under the headline “What is not covered under this guarantee?” Within the guarantee period, the costs to remedy the fault e.g. repairs, parts, labour and travel will be covered, provided that the appliance is accessible for repair without special expenditure. On these conditions the EU guidelines (Nr. 99/44/EG) and the respective local regulations are applicable. Replaced parts become the property of IKEA.

What will IKEA do to correct the problem?

IKEA appointed service provider will examine the product and decide, at its sole

discretion, if it is covered under this guarantee. If considered covered, IKEA service provider or its authorized service partner through its own service operations, will then, at its sole discretion, either repair the defective product or replace it with the same or a comparable product.

What is not covered under this guarantee?

- Normal wear and tear.
- Deliberate or negligent damage, damage caused by failure to observe operating instructions, incorrect installation or by connection to the wrong voltage, damage caused by chemical or electro-chemical reaction, rust, corrosion or water damage including but not limited to damage caused by excessive lime in the water supply, damage caused by abnormal environmental conditions.
- Consumable parts including batteries and lamps.
- Non-functional and decorative parts which do not affect normal use of the appliance, including any scratches and possible color differences.
- Accidental damage caused by foreign objects or substances and cleaning or unblocking of filters, drainage systems or soap drawers.
- Damage to the following parts: ceramic glass, accessories, crockery and cutlery baskets, feed and drainage pipes, seals, lamps and lamp covers, screens, knobs, casings and parts of casings. Unless such damages can be proved to have been caused by production faults.
- Cases where no fault could be found during a technician's visit.
- Repairs not carried out by our appointed service providers and/or an authorized service contractual partner or where non-original parts have been used.
- Repairs caused by installation which is faulty or not according to specification.
- The use of the appliance in a non-domestic environment i.e. professional use.
- Transportation damages. If a customer transports the product to their home or other address, IKEA is not liable for any damage that may occur during transport. However, if IKEA delivers the product to the customer's delivery address, then damage to the product that occurs during this delivery will be covered by this guarantee.
- Cost for carrying out the initial installation of the IKEA appliance. However, if an IKEA service provider or its authorized service partner repairs or replaces the appliance under the terms of this guarantee, the service provider or its authorized service partner will re-install the repaired appliance or install the replacement, if necessary.

This restriction do not apply to fault-free work carried out by a qualified specialist using our original parts in order to adapt the appliance to the technical safety specifications of another EU country.

How country law applies

The IKEA guarantee gives You specific legal rights, which covers or exceed local demands. However these conditions do not limit in any way consumer rights described in the local legislation

Area of validity

For appliances which are purchased in one EU country and taken to another EU country, the services will be provided in the framework of the guarantee conditions normal in the new country. An obligation to carry out services in the framework of the guarantee exists only if the appliance complies and is installed in accordance with:

- the technical specifications of the country in which the guarantee claim is made;

- the Assembly Instructions and User Manual Safety Information;

The dedicated After Sales Service for IKEA appliances:

Please do not hesitate to contact IKEA After Sales Service to:

1. make a service request under this guarantee;
2. ask for clarification on installation of the IKEA appliance in the dedicated IKEA kitchen furniture. The service won't provide clarifications related to:
 - the overall IKEA kitchen installation;
 - connections to electricity (if machine comes without plug and cable), to water and to gas since they have to be executed by an authorized service engineer.
3. ask for clarification on user manual contents and specifications of the IKEA appliance.

To ensure that we provide you with the best assistance, please read carefully the Assembly Instructions and/or the User Manual section of this booklet before contacting us.

How to reach us if You need our service



Please refer to the last page of this manual for the full list of IKEA appointed contacts and relative national phone numbers.

i In order to provide You with a quicker service, we recommend that You use the specific phone numbers listed at the end of this manual. Always refer to the numbers listed in the booklet of the specific appliance You need an assistance for. Before calling us, assure that You have to hand the IKEA article number (8 digit code) for the appliance of which you need our assistance.

i **SAVE THE SALES RECEIPT!** It is Your proof of purchase and required for the guarantee to apply. Note that the receipt reports also the IKEA article name and number (8 digit code) for each of the appliances you have purchased.

Do You need extra help?

For any additional questions not related to After Sales of your appliances, please contact our nearest IKEA store call centre. We recommend you read the appliance documentation carefully before contacting us.

| Country | Phone number | Call Fee | Opening time |
|-----------------|--|---|--|
| België | 070 246016 | Binnenlandse gesprekskosten | 8 tot 20 Weekdagen |
| Belgique | | Tarif des appels nationaux | 8 à 20. En semaine |
| България | 00359888164080 0035924274080 | Такса за повикване от страната | От 9 до 18 ч в работни дни |
| Česká republika | 246 019721 | Cena za místní hovor | 8 až 20 v pracovních dnech |
| Danmark | 70 15 09 09 | Landstakst | man. - fre. 09.00 - 20.00 lør. 09.00 - 16.00 1 søndag pr. måned, normalt første søndag i måneden |
| Deutschland | +49 1806 33 45 32* | * 0,20 €/Verbindung aus dem Festnetz max. 0,60 €/Verbindung aus dem Mobilfunknetz | Werktags von 8.00 bis 20.00 |
| Ελλάδα | 211 176 8276 | Υπεραστική κλήση | 8 έως 20 κατά τις εργάσιμες ημέρες |
| España | 91 1875537 | Tarifa de llamadas nacionales | De 8 a 20 en días laborables |
| France | 0170 36 02 05 | Tarif des appels nationaux | 9 à 21. En semaine |
| Hrvatska | 00385 1 6323 339 | Trošak poziva 27 lipa po minuti | radnik danom od ponedjeljka do petka od 08:00 do 16:00 |
| Ireland | 0 14845915 | National call rate | 8 till 20 Weekdays |
| Ísland | 5880503 | Innanlandsgjald fyrir síma | 9 til 18. Virka daga |
| Italia | 02 00620818 | Tariffa applicata alle chiamate nazionali | dalle 8 alle 20 nei giorni feriali |
| Κυπρος | 22 030 529 | Υπεραστική κλήση | 8 έως 20 κατά τις εργάσιμες ημέρες |
| Lietuva | 5 230 06 99 | Nacionalinių pokalbių tarifai | Pr. - Ketv.: 8:00 - 12:00, 12:45 - 17:00 Pntk.: 8:00 - 12:00, 12:45 - 15:45 |
| Magyarország | 061 998 0549 | Belföldi díjszabás | Hétköznapi 8 és 10 óra között |
| Nederland | 0900 235 45 32 en/of 0900 BEL IKEA | 15 cent/min., starttarief 4.54 cent en gebruikelijke belkosten | ma - vr 08.00 - 20.00, zat 09.00 - 20.00 (zondag gesloten) |
| Norge | 815 22052 | Takst innland | 8 til 20 ukedager |
| Österreich | 0810 300486 | max. 10 Cent/min. | Mo - Fr 8.00 - 20.00 Uhr |
| Polska | 012 297 8787 | Stawka wg taryfy krajowej | Od 8 do 20 w dni robocze |
| Portugal | 211557985 | Chamada Nacional | 9 às 21. Dias de Semana *excepto feriados |
| România | 021 211 08 88 | Tarif apel național | 8 - 20 în zilele lucrătoare |
| Россия | 8 495 6662929 | Действующие телефонные тарифы | с 8 до 20 по рабочим дням Время московское |
| Schweiz | 031 5500 324 | Tarif für Anrufe im Bundesgebiet | 8 bis 20 Werktage |
| Suisse | | Tarif des appels nationaux | 8 à 20. En semaine |
| Svizzera | | Tariffa applicata alle chiamate nazionali | dalle 8 alle 20 nei giorni feriali |
| Slovensko | (02) 3300 2554 | Cena vnútroštátneho hovoru | 8 až 20 v pracovných dňoch |
| Suomi | 030 6005203 | Lankapuhelinverkosta 0,0835 €/puhelu + 0,032 €/min Matkapuhelinverkosta 0,192 €/min | arkipäivisin 8.00 - 20.00 |
| Sverige | 0775 700 500 | lokalsamtal (lokal taxa) | mån-fre 8.30 - 20.00 lör-sön 9.30 - 18.00 |
| Türkiye | 212 244 0769 | Ulusal arama ücreti | Hafta içi saat 09:00'dan 18:00'a kadar |
| Україна | 044 586 2078 | Міжміські дзвінки платні | 9 - 21 В робочі дні |
| United Kingdom | 020 3347 0044 | National call rate | 9 till 21. Weekdays |
| Slovenija | | www.ikea.com | |
| Србија | | www.ikea.com | |

