

# FANBYN

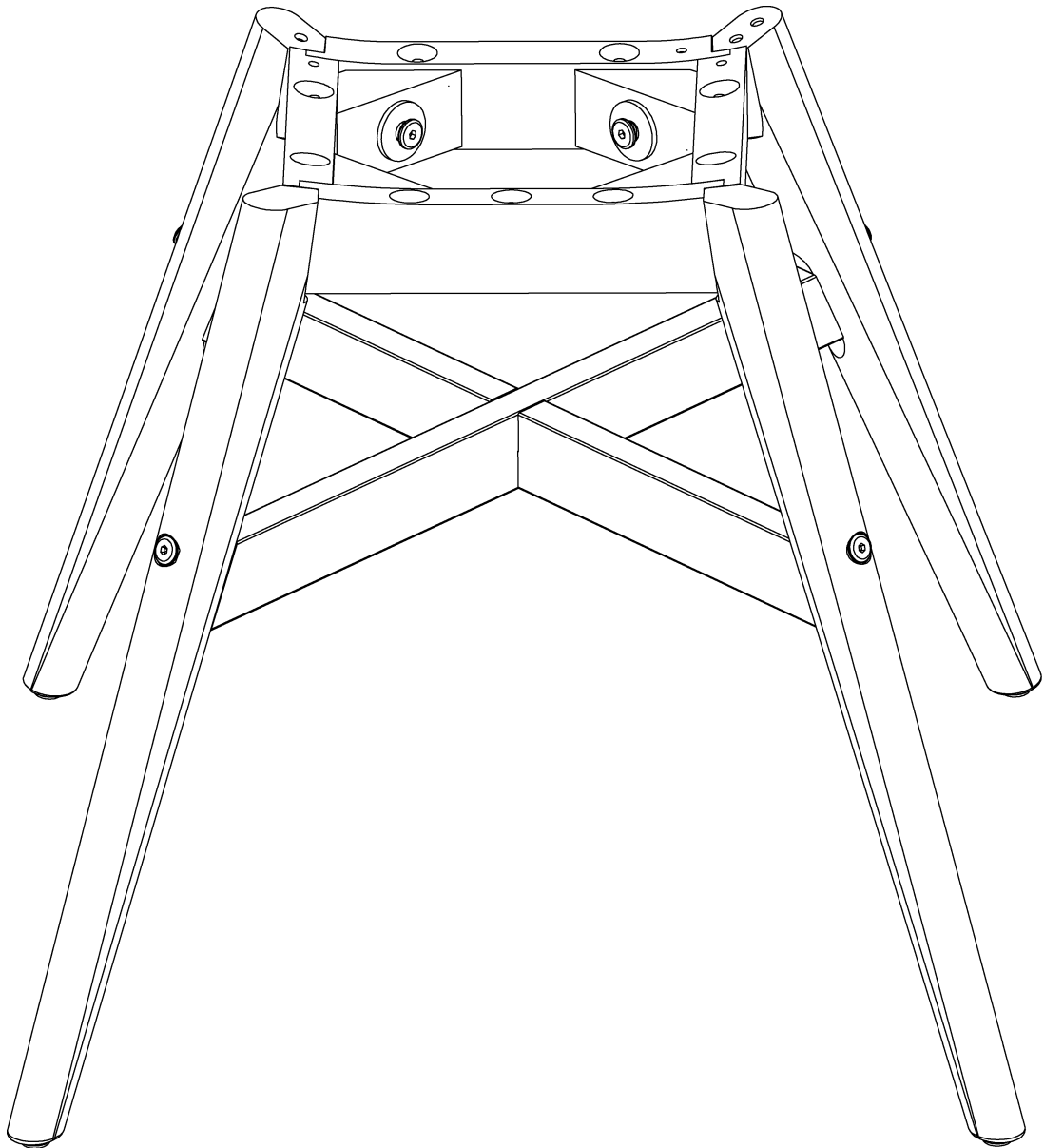

Design and Quality  
IKEA of Sweden

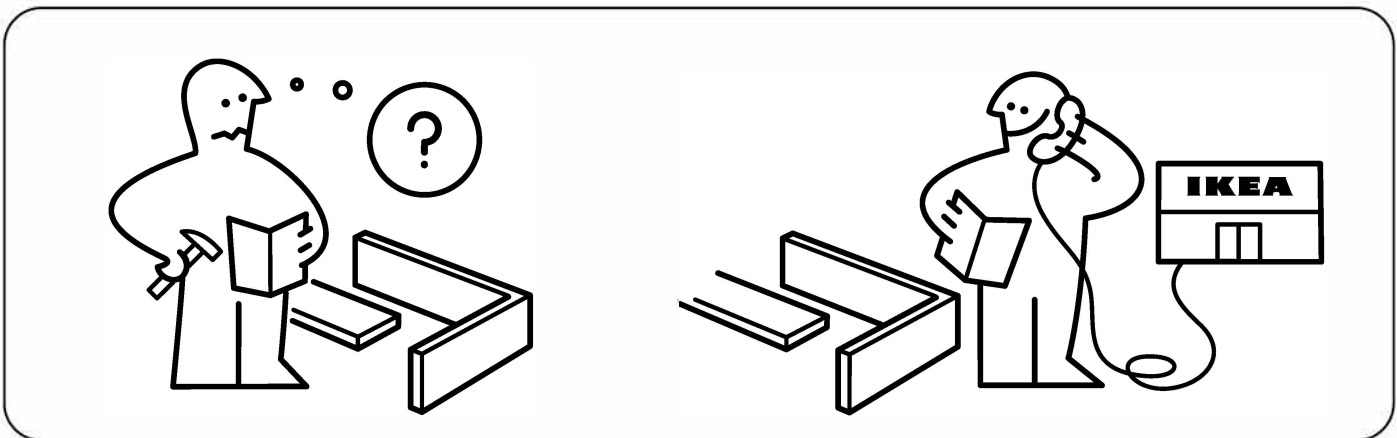
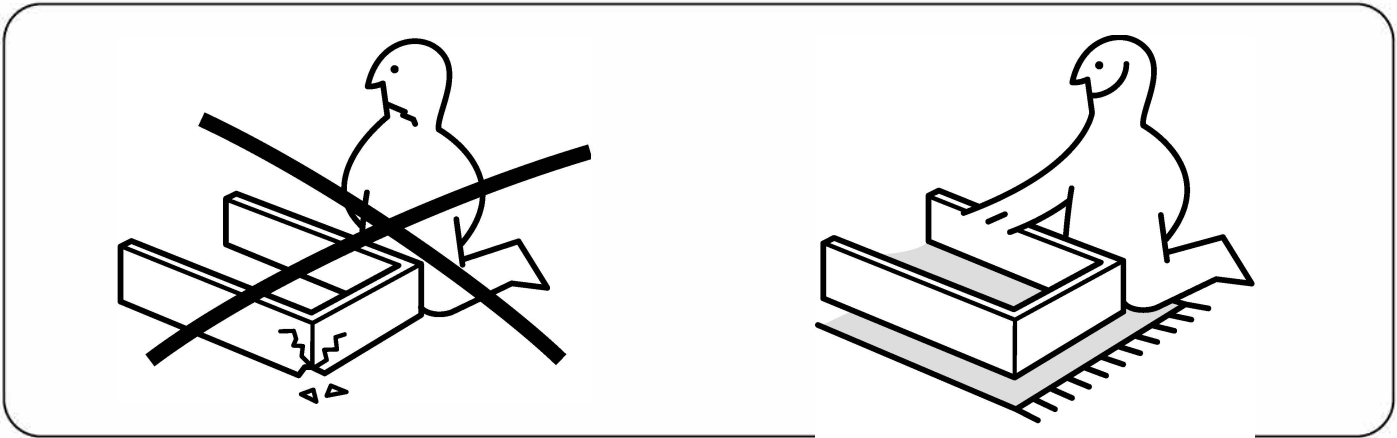

## ENGLISH

Make sure that you tighten the screws well. For increased stability, re-tighten the screws about two weeks after assembly.

## DEUTSCH

Darauf achten, dass die Schrauben fest angezogen sind. Zur Erhöhung der Stabilität die Schrauben ca. 2 Wochen nach der Montage erneut anziehen.

## FRANÇAIS

S'assurer que les vis sont correctement serrées. Pour plus de stabilité, resserrer les vis environ deux semaines après le montage.

## NEDERLANDS

Draai de schroeven goed aan. Voor extra stabiliteit adviseren we de schroeven ca. twee weken na de montage opnieuw aan te draaien.

## DANSK

Sørg for at stramme skruerne godt. For at opnå større stabilitet skal skruerne efterspændes ca. 2 uger efter, at produktet er blevet samlet.

## ÍSLENSKA

Nauðsynlegt er að herða skrúfurnar vel. Herðið skrúfurnar aftur tveimur vikum eftir samsetningu, til að auka stöðugleikann.

## NORSK

Sørg for at du strammer skruene godt. For økt stabilitet, etterstram skruene ca. 2 uker etter montering.

## SUOMI

Varmista, että ruuvit on kiristetty hyvin. Tukevuuden parantamiseksi ruuvit on hyvä kiristää uudelleen kahden viikon kuluttua kokoamisesta.

## SVENSKA

Var noga med att dra åt skruvarna ordentligt. För ökad stabilitet, dra åt skruvarna på nytt cirka två veckor efter montering.

## ČESKY

Ujistěte se, že jsou šroubky dotaženy. Pro větší stabilitu šroubky dotáhněte přibližně 2 týdny po montáži.

## ESPAÑOL

Asegúrate de apretar bien los tornillos. Para mayor estabilidad, repásalos de nuevo unas dos semanas después del montaje.

## ITALIANO

Assicurati di serrare bene tutte le viti. Per una maggiore stabilità, stringi nuovamente le viti circa due settimane dopo il montaggio.

## MAGYAR

Ügyelj rá, hogy a csavarok jól meg legyenek húzva! A nagyobb stabilitás érdekében az összeszerelés után kb. két héttel ismét húzd meg a csavarokat.

## POLSKI

Upewnij się, że dobrze śruby są dobrze dokręcone. Aby zwiększyć stabilność, dokręć śruby ponownie po około dwóch tygodniach od zmontowania.

## EESTI

Veenduge, et pingutasite kõiki kruvisid korralikult. Stabiilsuse tõstmiseks pingutage kruvisid, kui paigaldamisest on möödunud umbes kaks nädalat.

## LATVIEŠU

Pārlicinieties, ka skrūves ir cieši pievilktas. 2 nedēļas pēc montāžas veikšanas skrūves ieteicams pievilkt atkārtoti.

## LIETUVIŲ

Tvirtai prisukite varžtus. Užtikrindami stabilumą, dar kartą priveržkite varžtus praėjus dviem savaitėm po surinkimo.

## PORTUGUÊS

Certifique-se de que os parafusos ficam bem apertados. Para maior estabilidade, volte a apertar os parafusos duas semanas após a montagem.

## ROMÂNĂ

Asigura-te că șuruburile sunt bine strânse. Pentru o stabilitate mai mare, strânge

din nou șuruburile la 2 săptămâni după asamblare.

## SLOVENSKY

Uistite sa, že skrutky sú pevne utiahnuté. Pre väčšiu stabilitu skrutky dotiahnite približne 2 týždne po montáži.

## БЪЛГАРСКИ

Уверете се, че винтовете са затегнати добре. За още повече стабилност, притегнете винтовете около две седмици след сглобяването.

## HRVATSKI

Vijci moraju biti čvrsto zategnuti. Kako biste povećali stabilnost, vijke ponovno zategnite otprilike dva tjedna nakon sastavljanja.

## ΕΛΛΗΝΙΚΑ

Βεβαιωθείτε ότι έχετε σφίξει τις βίδες καλά. Για μεγαλύτερη σταθερότητα, ξανασφίξτε τις βίδες περίπου δύο εβδομάδες μετά τη συναρμολόγηση.

## РУССКИЙ

Убедитесь, что шурупы хорошо затянуты. Для обеспечения устойчивости подтяните шурупы через две недели после сборки.

## УКРАЇНСЬКА

Перевірте, щоб шурупи були

міцно затягнуто. Щоб забезпечити стабільність, перезатягніть шурупи через два тижні після складання.

## SRPSKI

Pobrini se da zavrtnje čvrsto zategneš. Radi veće stabilnosti, dotegni zavrtnje oko dve nedelje nakon sastavljanja proizvoda.

## SLOVENŠČINA

Vijaki morajo biti čvrsto priviti. Za boljšo stabilnost vijake dodatno pričvrsti približno dva tedna po montaži.

## TÜRKÇE

Vidaları tam olarak sıkıtiğınızdan emin olunuz. Denge ve sağlamlığı arttırmak için

## 中文

确保螺丝已拧紧，为增加稳定性请于组装完成后两周左右的时间再次加固螺丝。

## 繁中

確認鎖緊所有螺絲。組裝後兩個星期，重新旋緊螺絲，以增加穩固性。

## 한국어

제품 조립에 사용된 모든 스크류가 단단히 조여졌는지 확인해 주세요. 조립 후 2주가 지난 뒤 다시 조여주면 더욱 안전합니다.

## 日本語

必ずネジをしっかりと締めてください。安定性を高めるため、組み立てから約2週間後にネジを締め直してください。

## BAHASA INDONESIA

Pastikan bahwa anda kencangkan sekrup dengan baik. Untuk peningkatan stabilitas, kencangkan kembali sekrup sekitar dua minggu setelah perakitan.

## BAHASA MALAYSIA

Pastikan anda betul-betul mengetatkan skru. Untuk lebih kestabilan, ketatkan semula skru dua minggu selepas pemasangan.

عربي  
تأكد من ربط المسامير جيداً. لزيادة الثبات، أعيد ربط المسامير بعد نحو أسبوعين من التجميع.

## ไทย

ตรวจสอบว่าขันสกรูแน่นหนาดีแล้ว และหลังประกอบราว

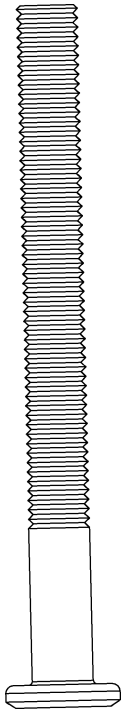

194005

4x



106675

4x

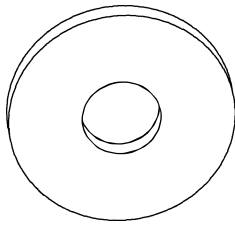

100837

4x

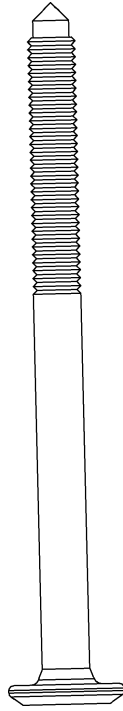

10003816

4x

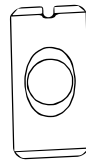

113153

4x

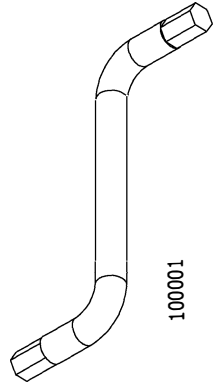

100001

1x

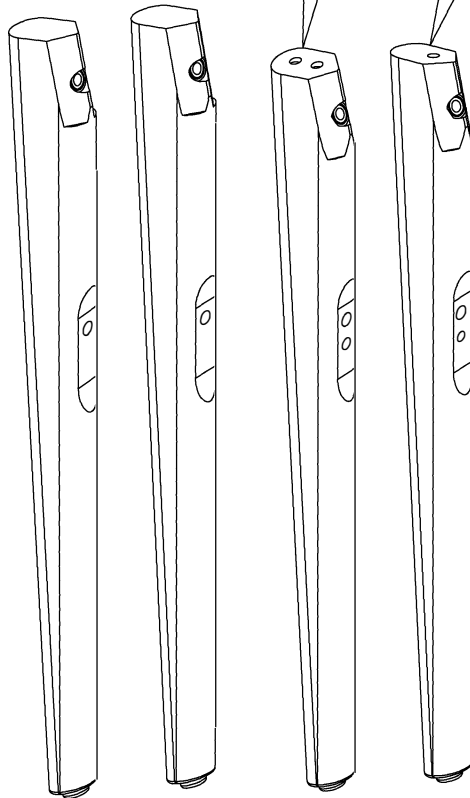
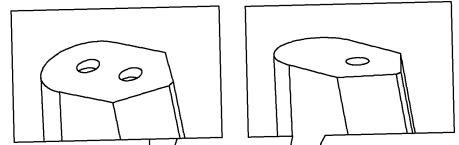
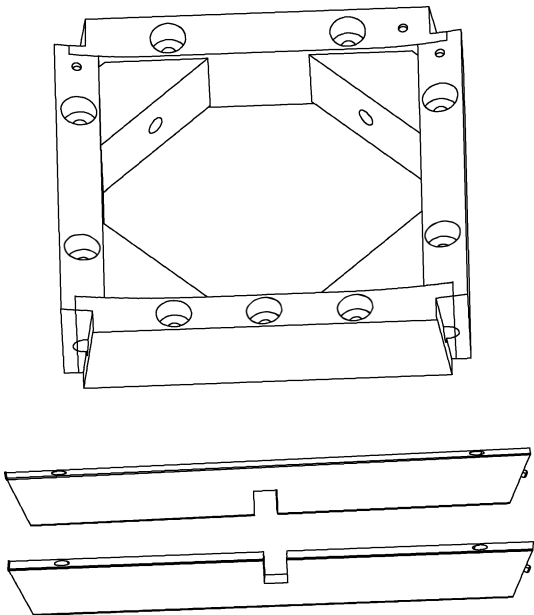

1

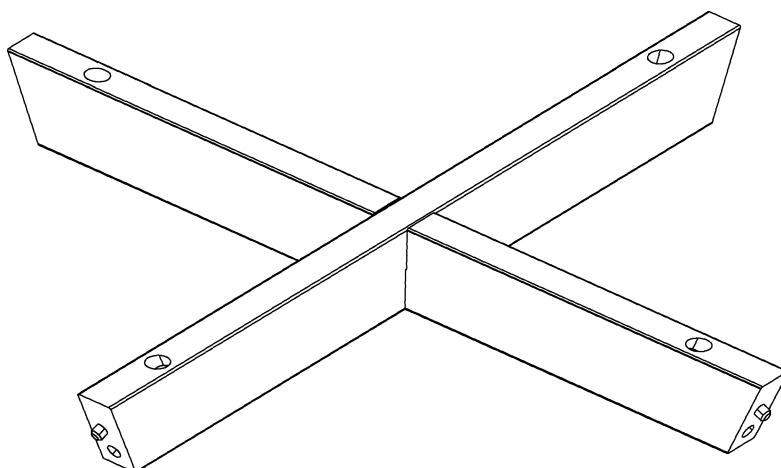
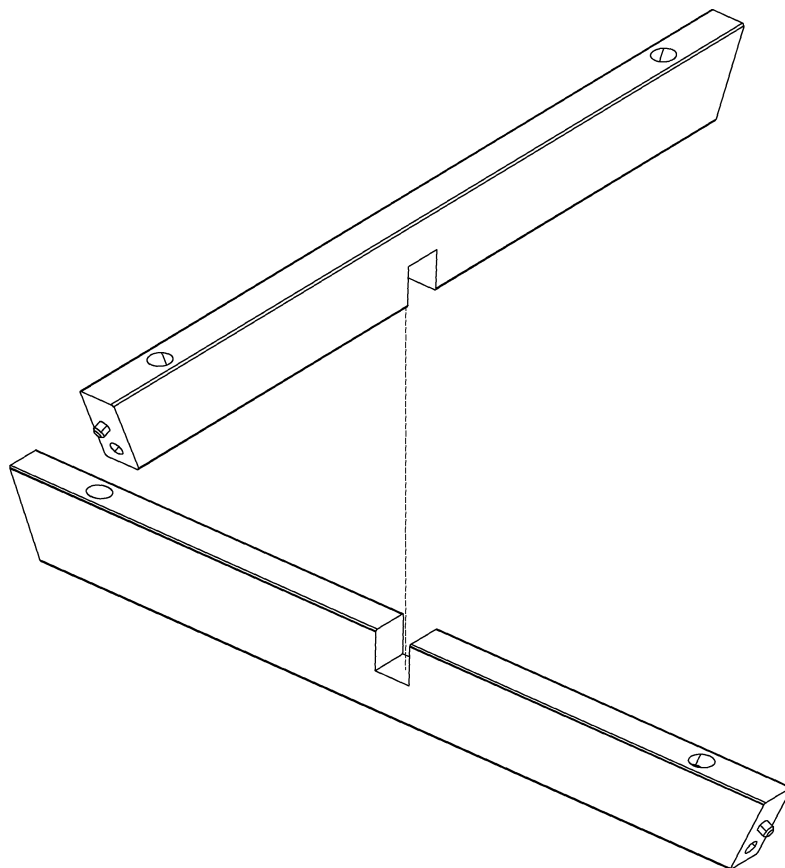

2

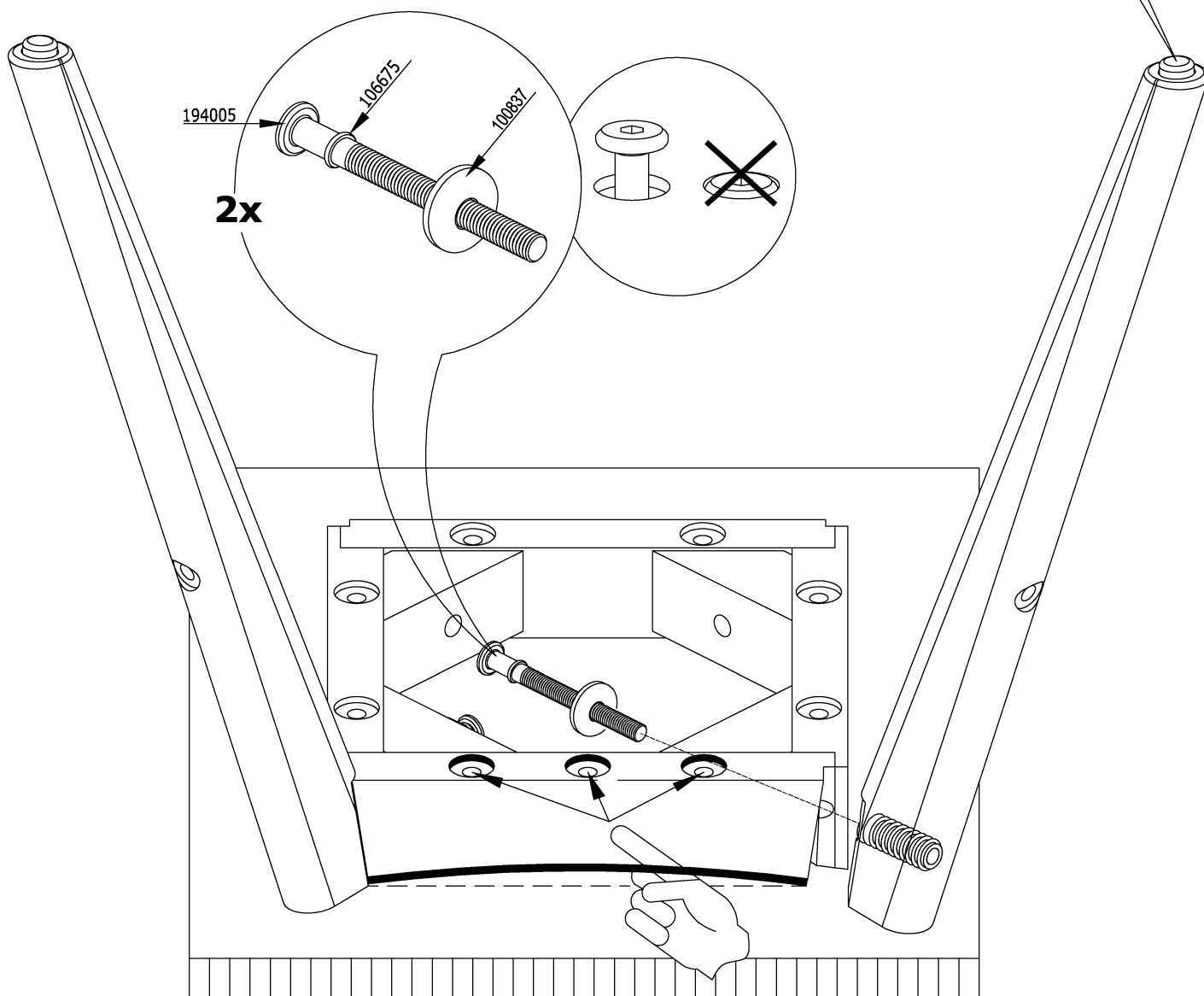
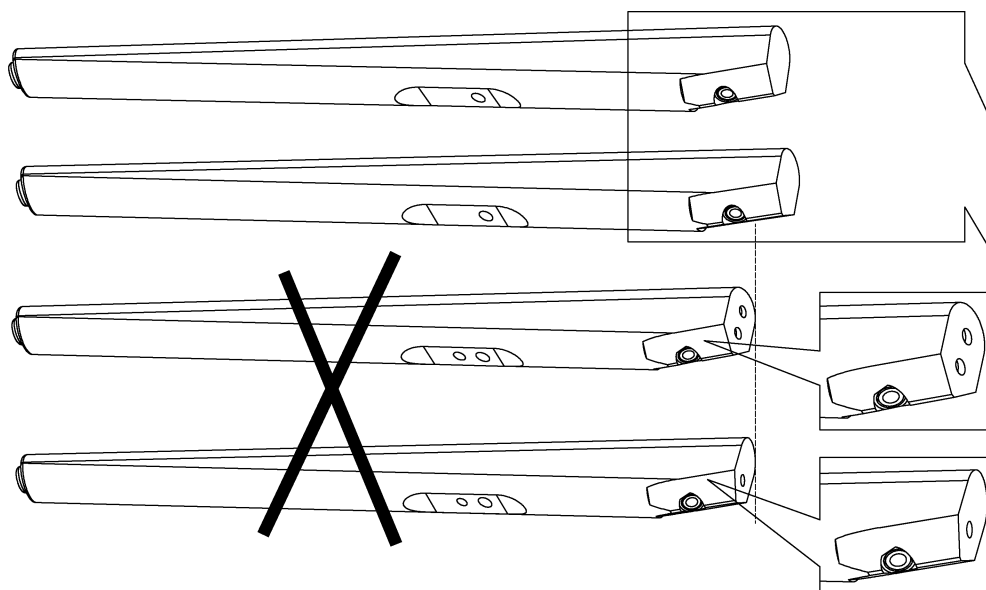

3

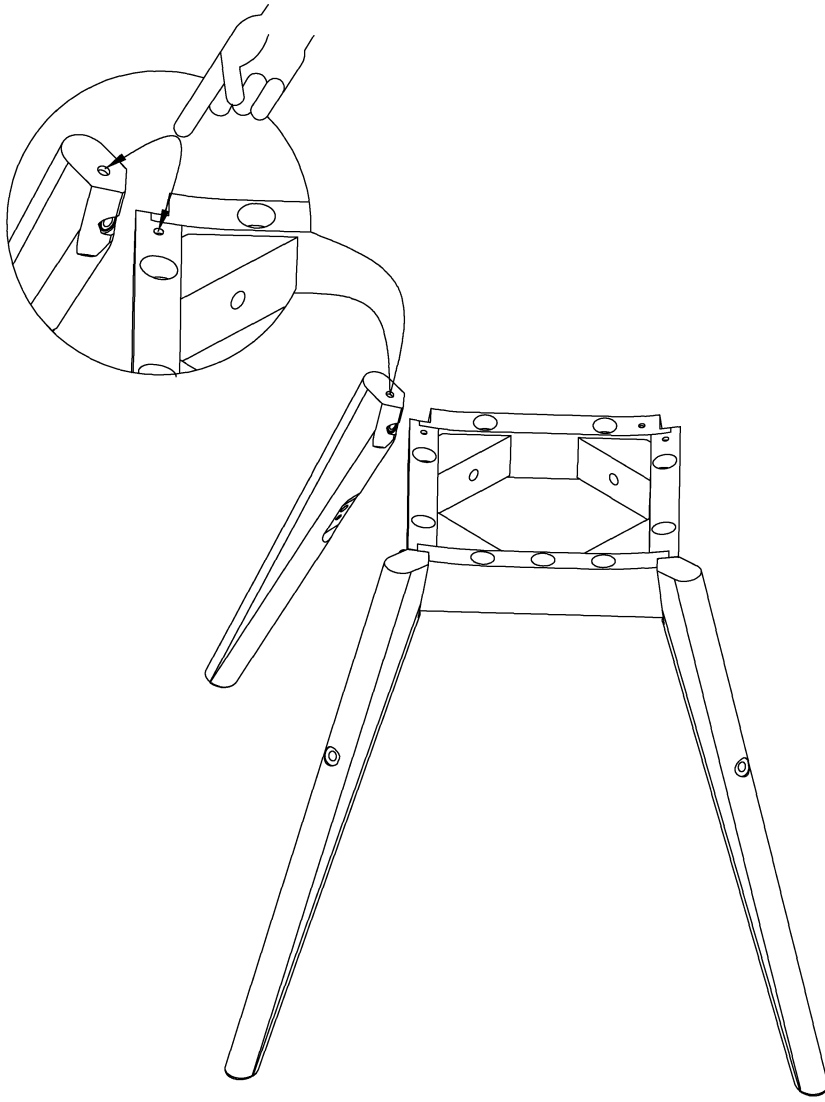

4

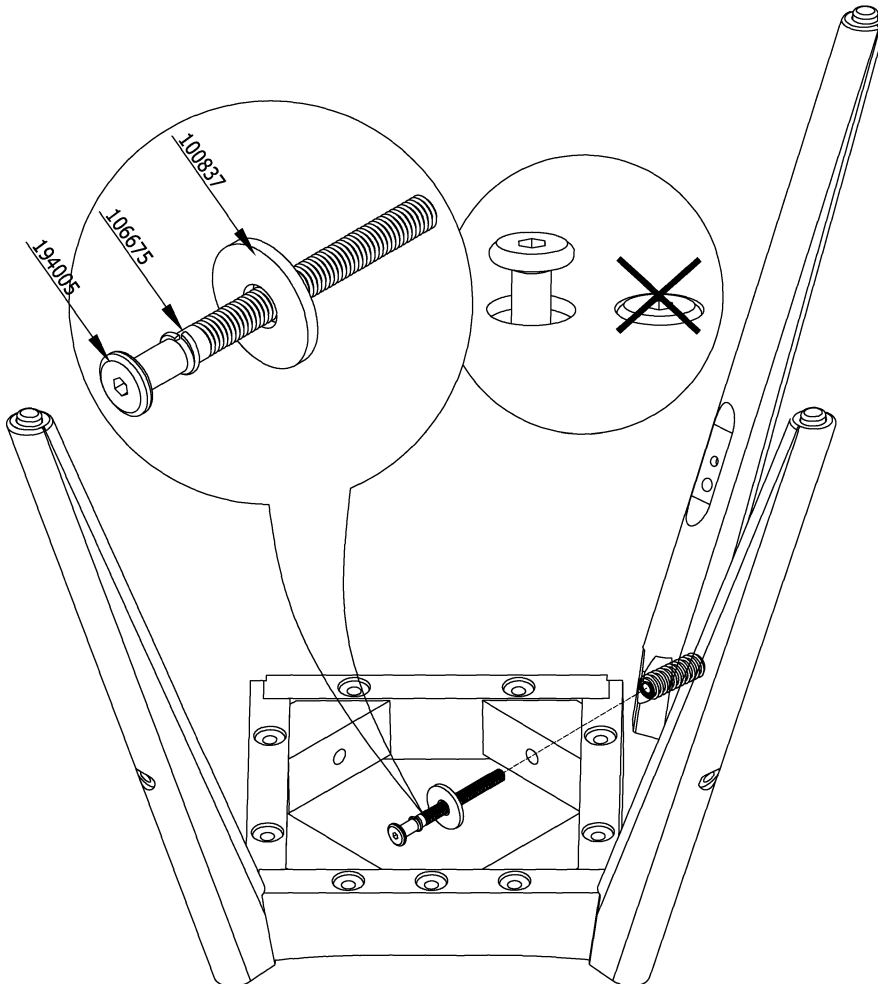

5

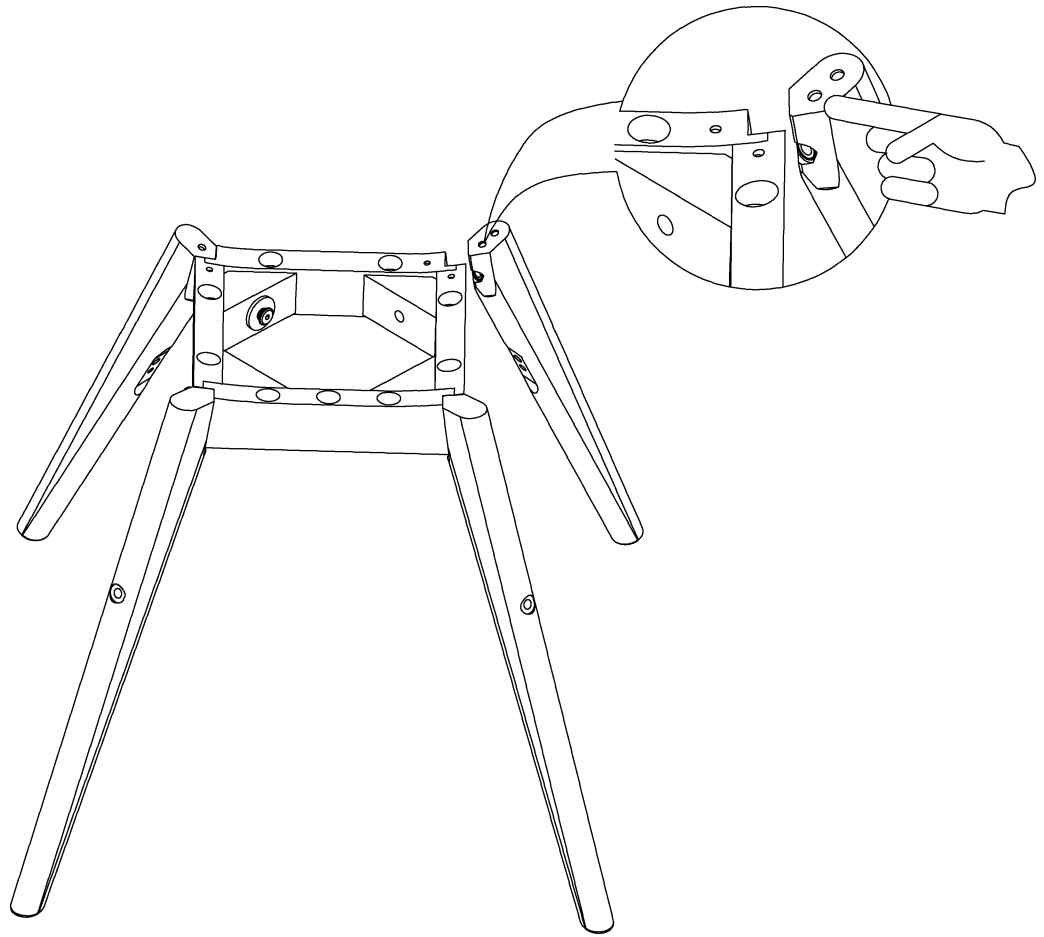

6

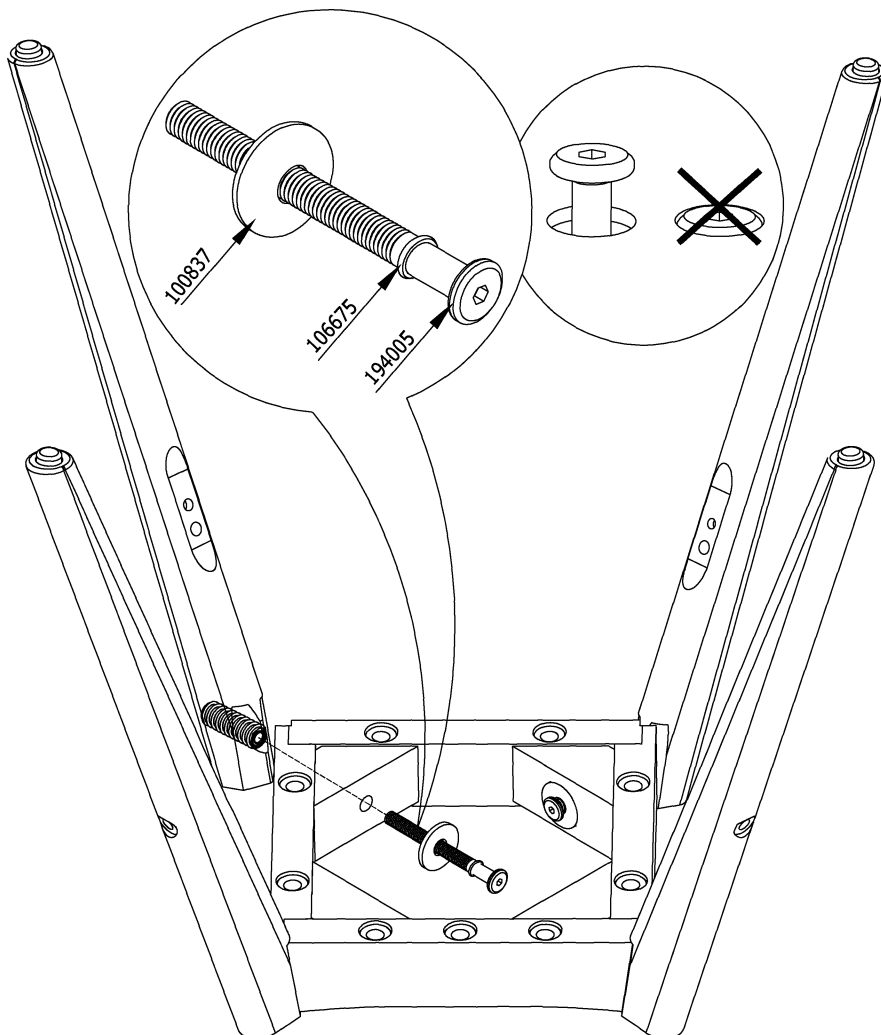



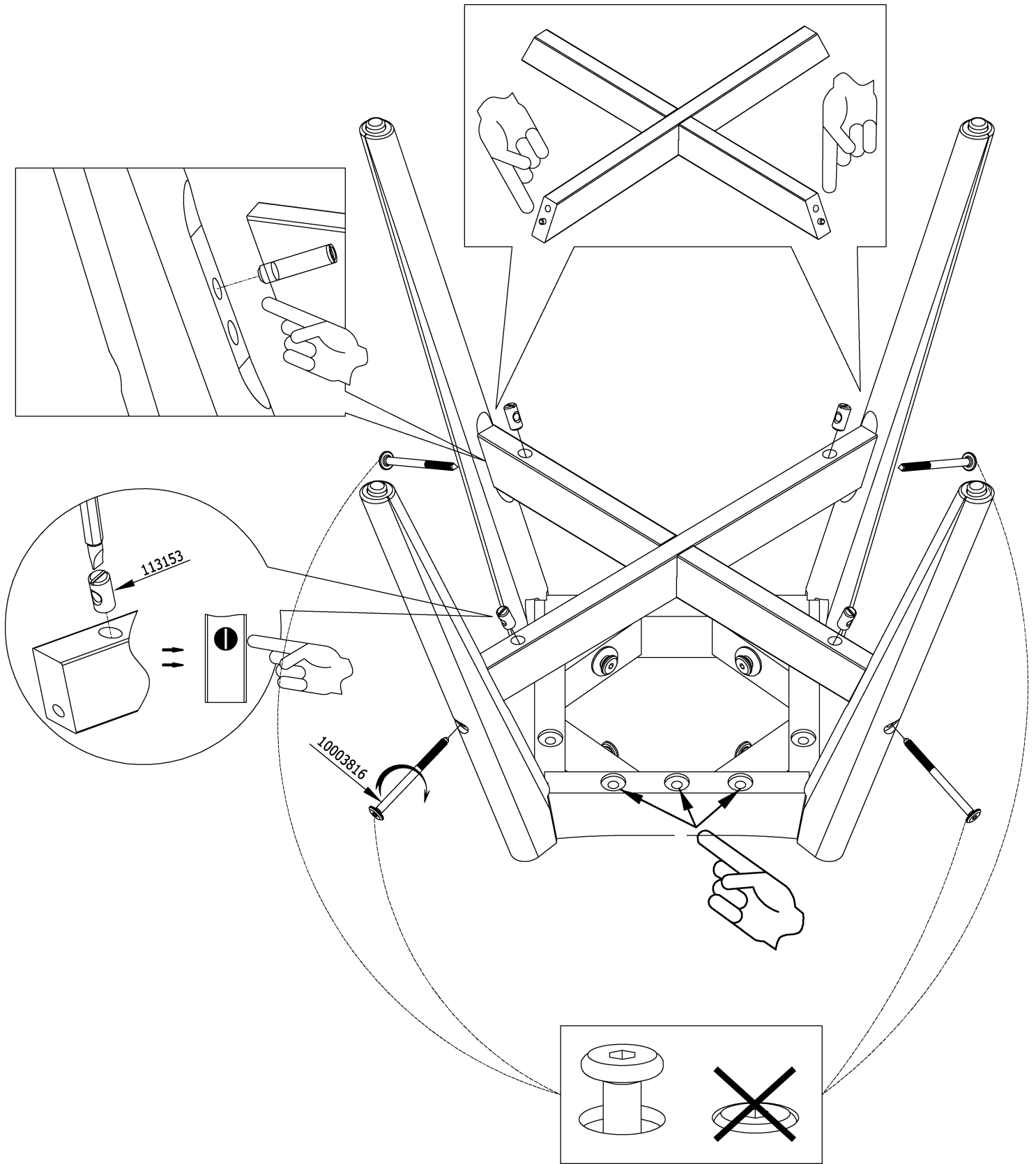

8

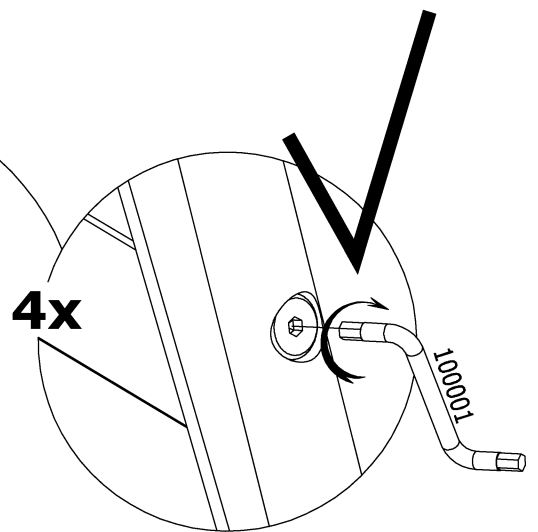
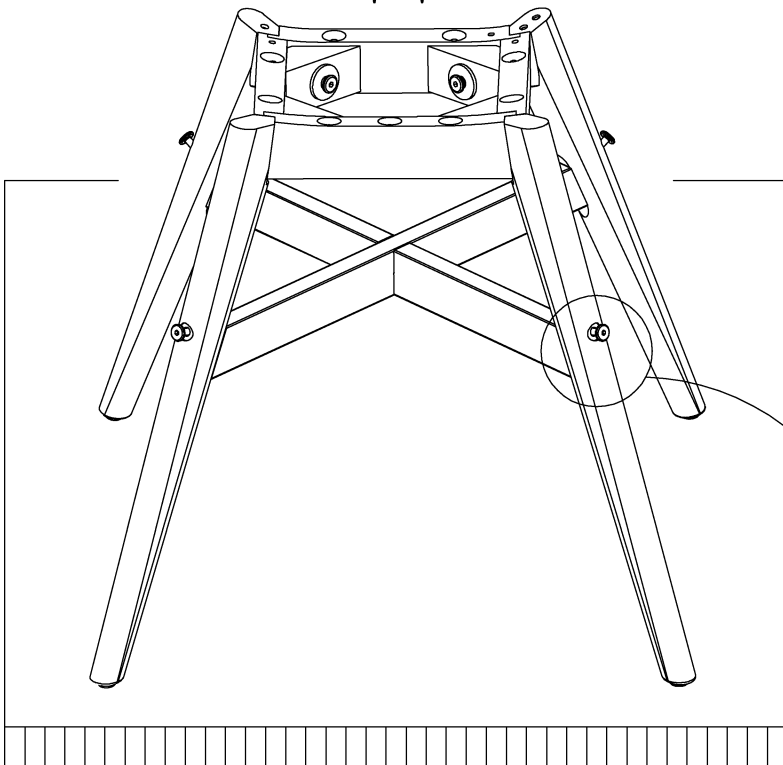
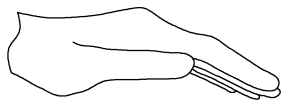
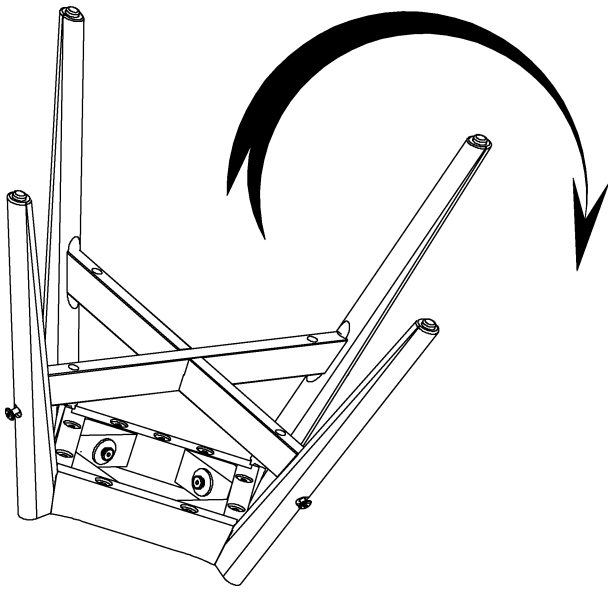

9

