

FINGAL

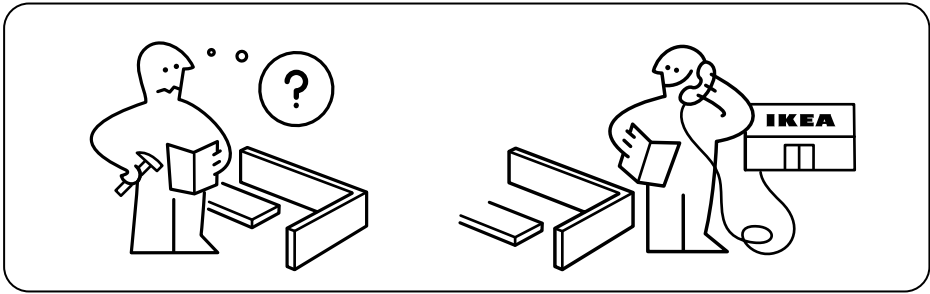

Design and Quality
IKEA of Sweden

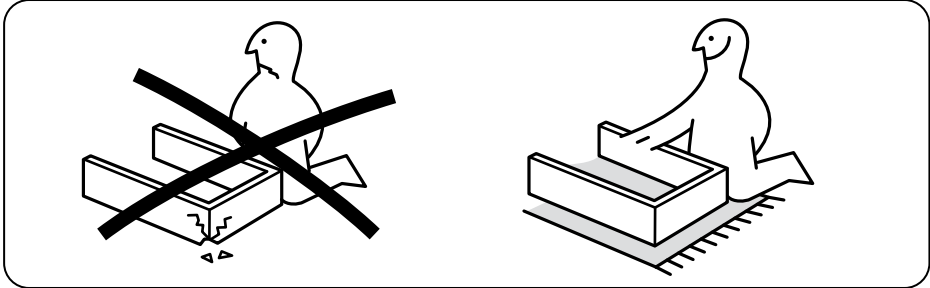

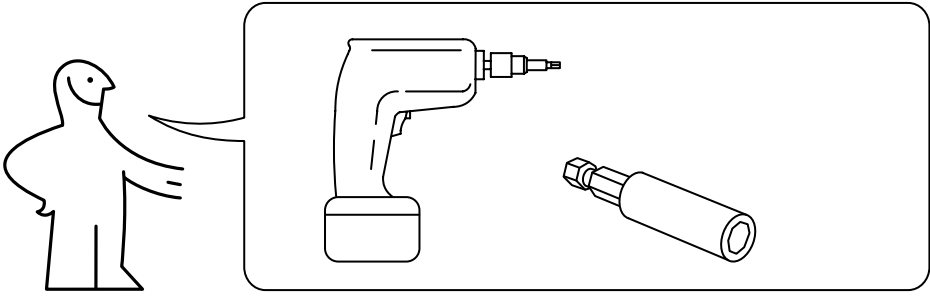
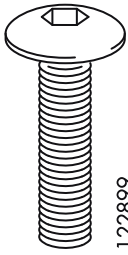

8x

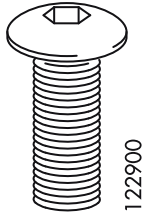

4x

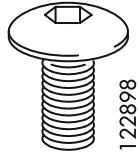

10x

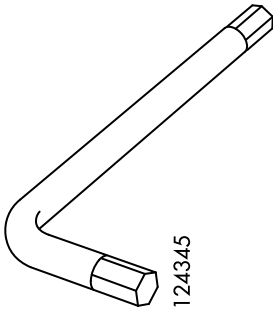

1x

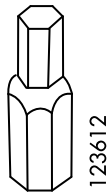

1x

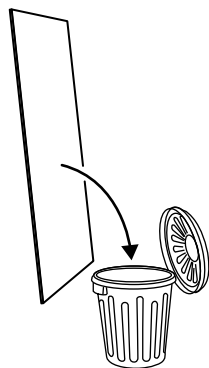
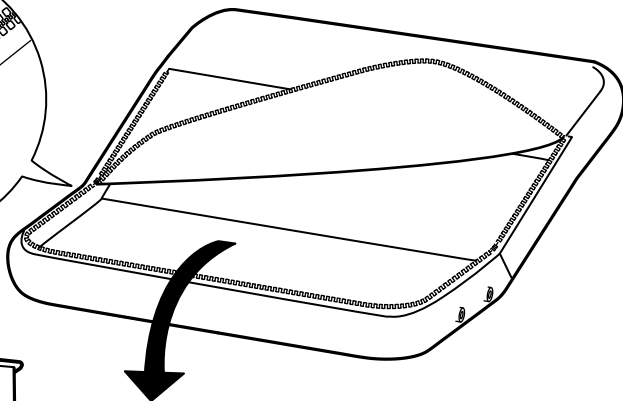
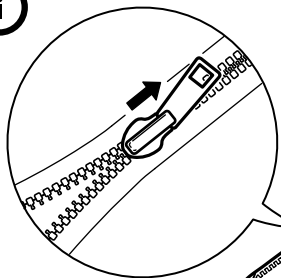

1x

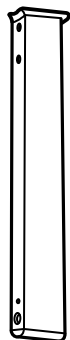

5x

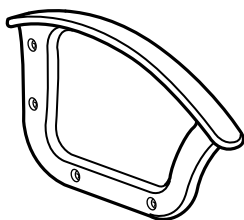

2x

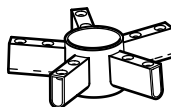

1x



5x

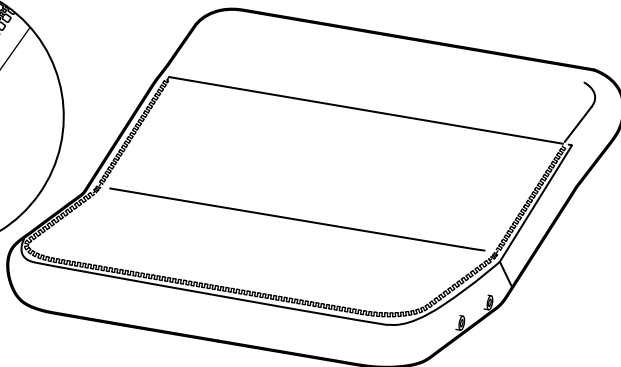
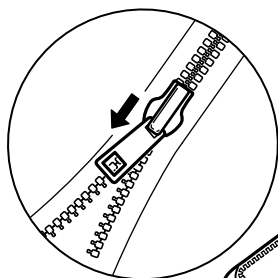

1

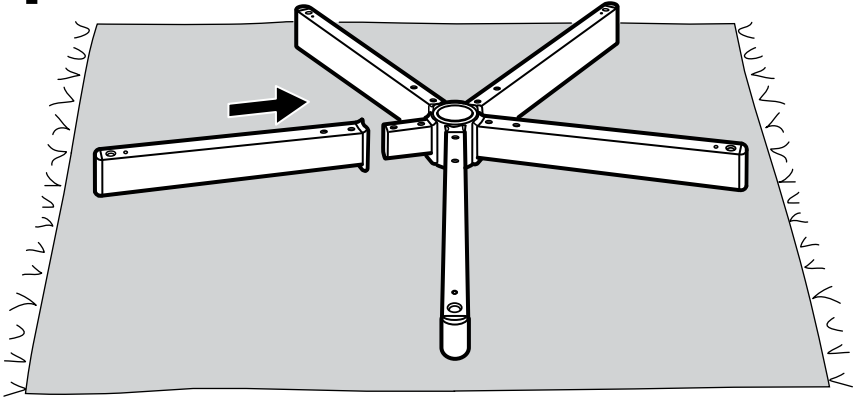

2

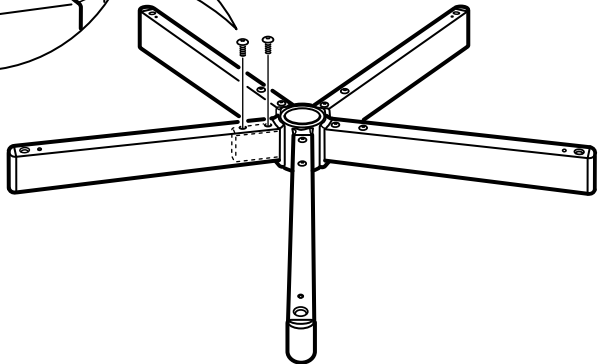
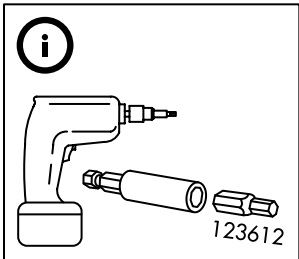
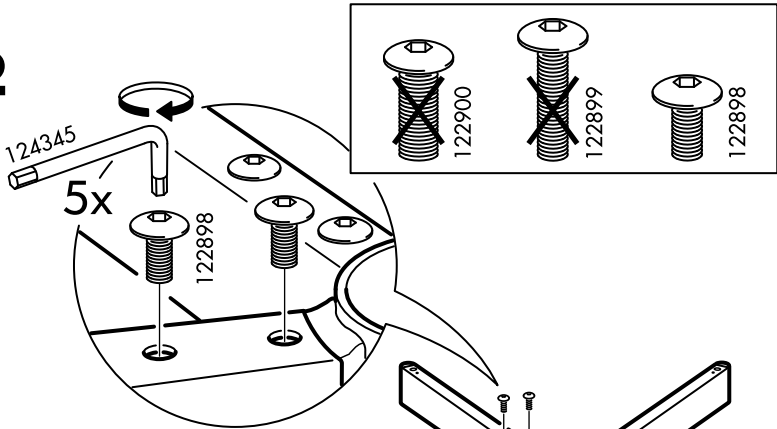

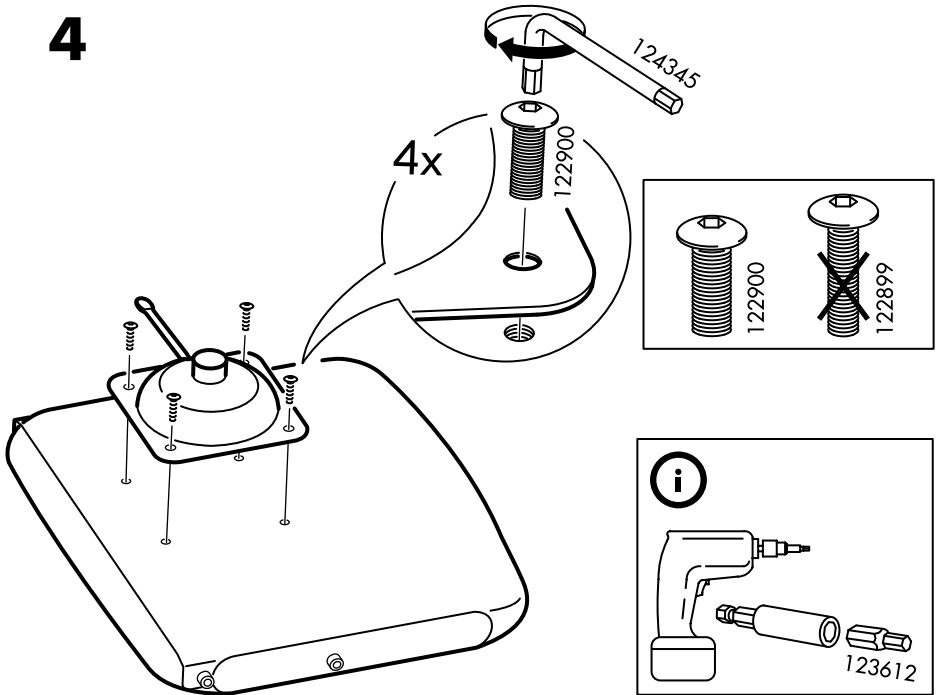
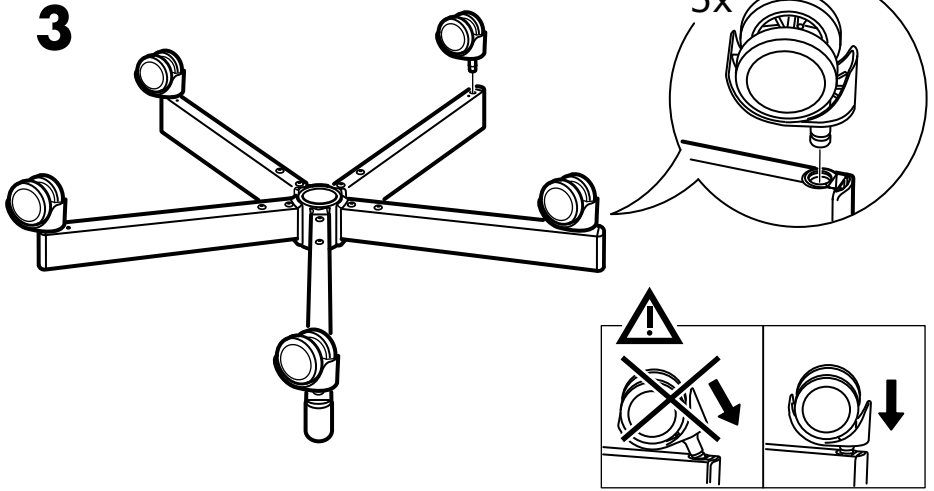

5

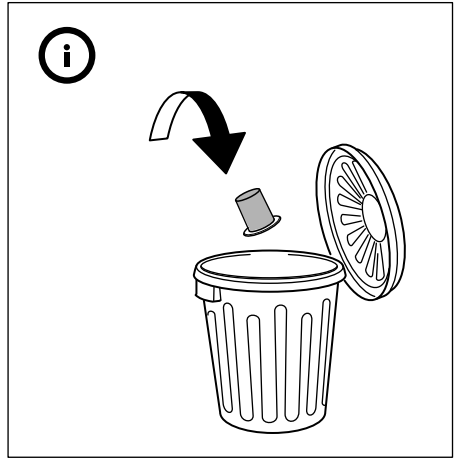

6

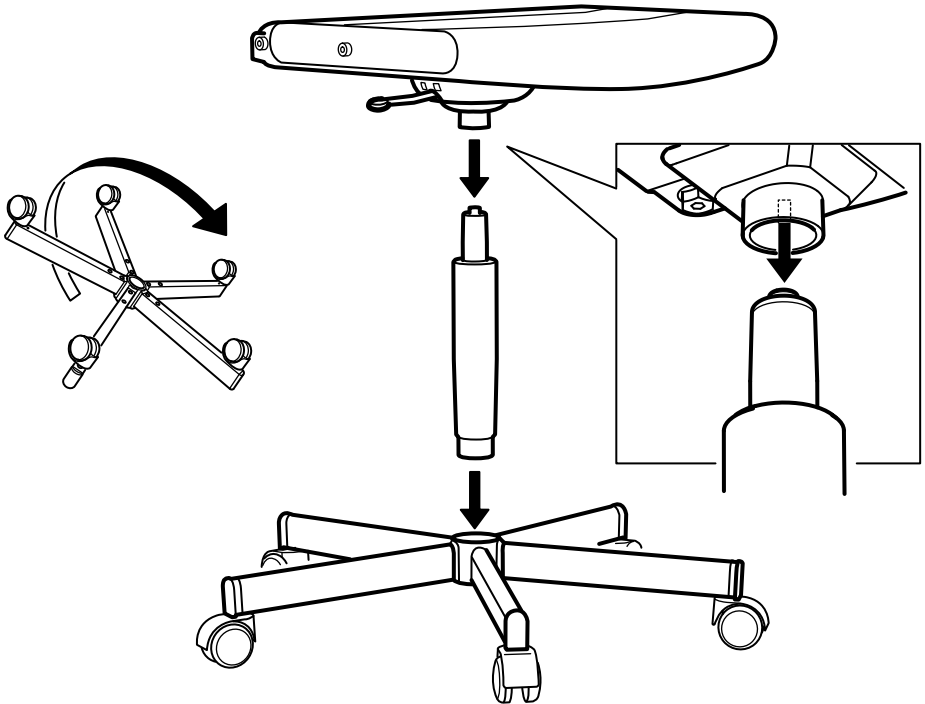

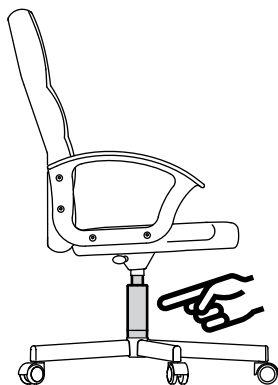
**ENGLISH**

Do not try to replace or repair.

DEUTSCH

Nie selbst austauschen oder reparieren.

FRANÇAIS

Ne pas essayer de remplacer ou de réparer.

NEDERLANDS

Niet proberen te vervangen of repareren.

DANSK

Må ikke udskiftes eller repareres.

ÍSLENSKA

Reynið ekki að skipta út eða gera við.

NORSK

Forsøk aldri å bytte ut eller reparere selv.

SUOMI

Älä yritä vaihtaa tai korjata.

SVENSKA

Försök aldrig ersätta eller laga själv.

ČESKY

Nesnažte se vyměnit nebo opravit.

ESPAÑOL

No intentes repararlo o reemplazarlo.

ITALIANO

Non effettuare alcuna sostituzione o riparazione.

MAGYAR

Ne próbáld meg kicserélni vagy megjavítani!

POLSKI

Nie próbuj wymieniać, ani naprawiać.

LIETUVIŲ

Nemėginkite pakeisti ar remontuoti.

PORTUGUÊS

Não tente reparar nem substituir.

ROMÂNĂ

Nu încerca să schimbi sau să reperi.

SLOVENSKY

Nepremiestňujte ani neopravujte.

БЪЛГАРСКИ

Не подменяйте и не ремонтирайте.

HRVATSKI

Ne zamijenjujte ili popravljajte.

ΕΛΛΗΝΙΚΑ

Μην προσπαθήσετε να αντικαταστήσετε ή να το επισκευάσετε.

РУССКИЙ

Не пытайтесь заменить или отремонтировать.

SRPSKI

Nemojte pokušati da popravite ili zamenite.

SLOVENŠČINA

Ne poskušajte zamenjati ali popraviti.

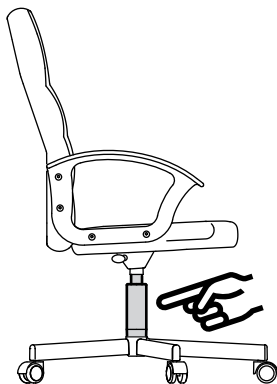

TÜRKÇE

Parçaları değiştirmeye veya tamir etmeye çalışmayınız.

中文

请勿自行更换或维修。

繁中

不可試圖更換或維修。

한국어

부품을 직접 교체하거나 수리하지 마세요.

日本語

パーツをほかのもので代用したり、自分で修理しないでください。

BAHASA INDONESIA

Hindari mencoba mengganti atau memperbaiki.

BAHASA MALAYSIA

Jangan cuba menggantikan atau membaikinya.

عربي

لا تحاول إستبداله أو إصلاحه.

ไทย

อย่าพยายามซ่อมหรือเปลี่ยนใหม่

7

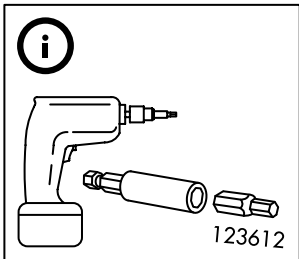
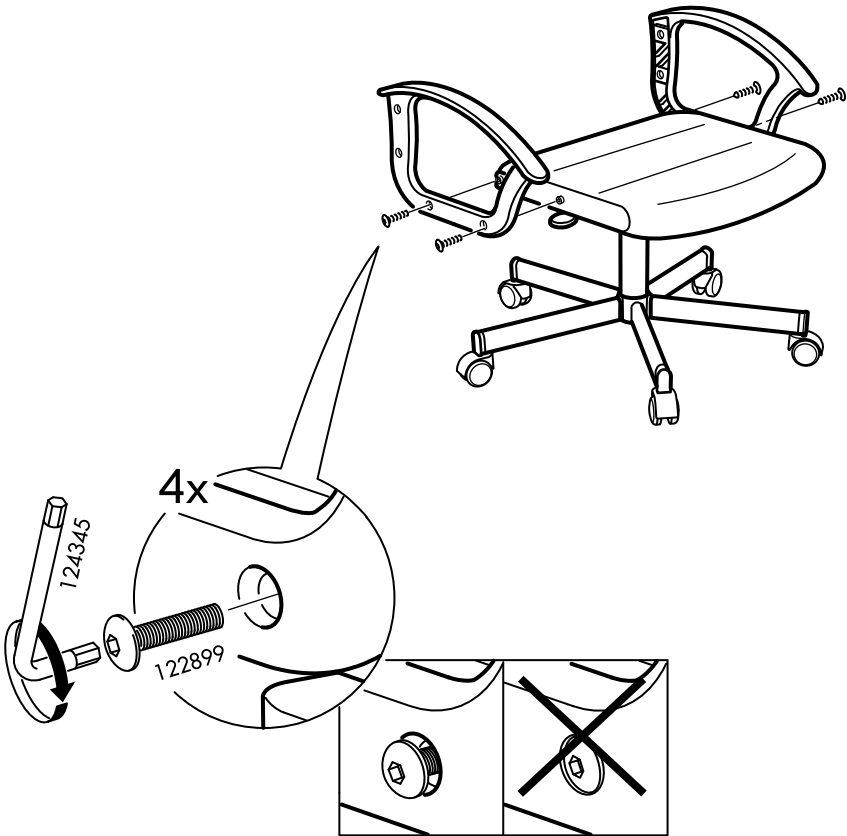

8

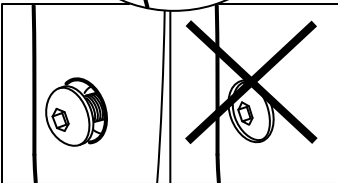
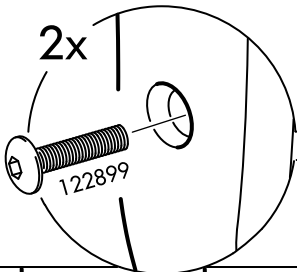
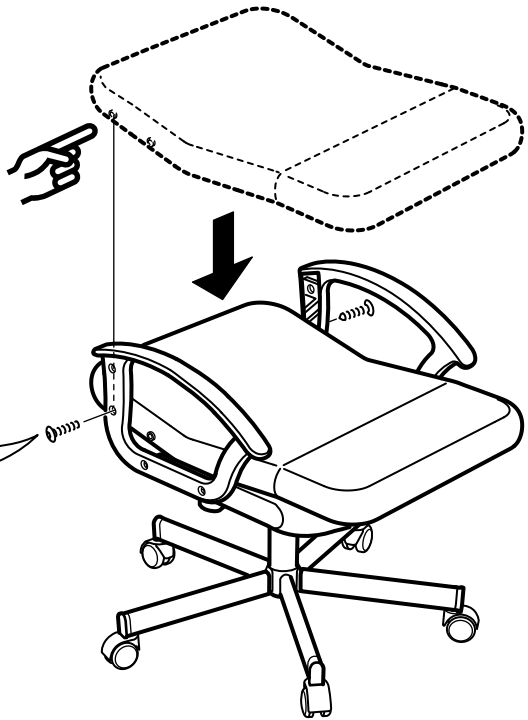

9

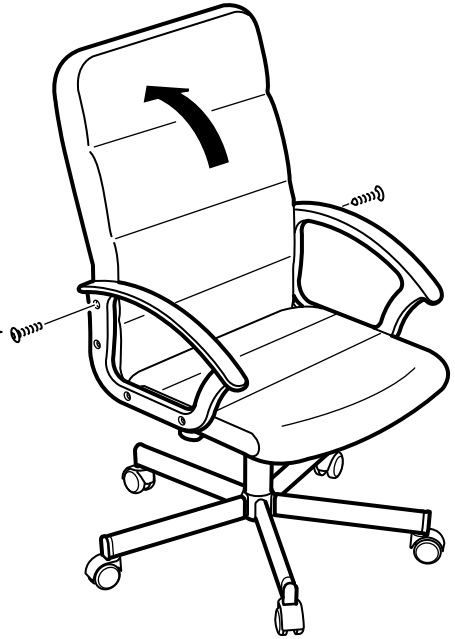
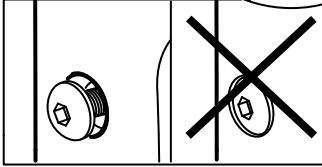
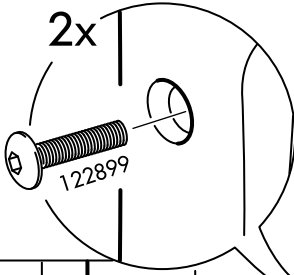

10

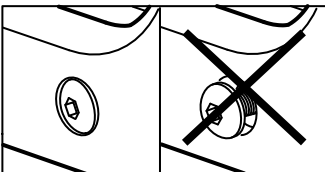
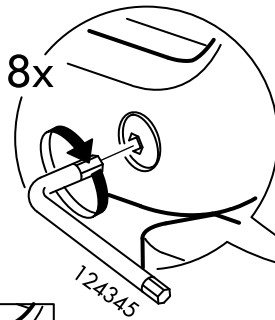

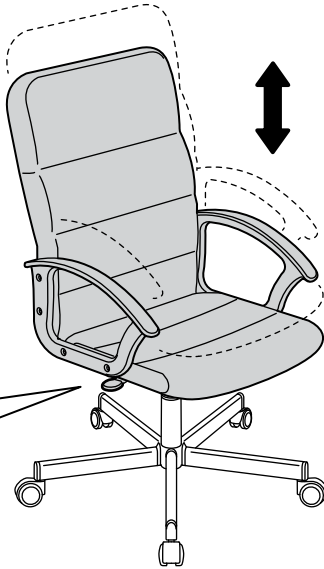
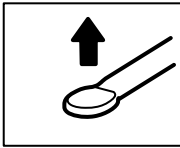



ENGLISH

For safety reasons the castors lock automatically when the chair is not in use.

DEUTSCH

Aus Sicherheitsgründen arretieren die Rollen automatisch, wenn der Stuhl nicht benutzt wird.

FRANÇAIS

Par mesure de sécurité, les roulettes se bloquent automatiquement quand le siège n'est pas utilisé.

NEDERLANDS

Om veiligheidsredenen vergrendelen de wielen automatisch als de stoel niet wordt gebruikt.

DANSK

Af sikkerhedshensyn låser hjulene automatisk, når stolen ikke er i brug.

ÍSLENSKA

Hjólin læsast sjálfkrafa í öryggisskyni þegar stóllinn er ekki í notkun.

NORSK

Av sikkerhetsgrunner låses hjulene automatisk når stolen ikke er i bruk.

SUOMI

Turvallisuussyistä pyörät lukkiutuvat itsestään, kun tuolia ei käytetä.

SVENSKA

Av säkerhetsskäl låser sig hjulen automatiskt när stolen inte används.

ČESKY

Z bezpečnostních důvodů se kolečka automaticky zablokují, když se židle nepoužívá.

ESPAÑOL

Por motivos de seguridad las ruedas se bloquean automáticamente cuando no se utiliza la silla.

ITALIANO

Per motivi di sicurezza, le rotelle si bloccano automaticamente quando la sedia non viene usata.

MAGYAR

A nagyobb biztonság érdekében a görgők automatikusan lefékeznek magukat, ha a szék nincs használatban.

POLSKI

Ze względów bezpieczeństwa kółka blokują się automatycznie, gdy krzesło nie jest używane.

LIETUVIŲ

Užtikrinant saugumą, ratukai automatiškai fiksuojami, kai kėdė nenaudojama.

PORTUGUÊS

Por motivos de segurança, os rodízios bloqueiam automaticamente quando a cadeira não está a ser usada.

ROMÂNĂ

Din motive de siguranță, rotilele se blochează automat atunci când scaunul nu este folosit.



SLOVENSKY

Z bezpečnostných sa kolieska automaticky zablokujú, keď sa stolička nepoužíva.

БЪЛГАРСКИ

С оглед на безопасността колелцата се заключават автоматично, когато столът не се използва.

HRVATSKI

Kotači se iz sigurnosnih razloga automatski zakleče kad se stolica ne koristi.

ΕΛΛΗΝΙΚΑ

Για λόγους ασφαλείας, τα ροδάκια κλειδώνουν αυτόματα όταν η καρέκλα δε χρησιμοποιείται.

РУССКИЙ

В целях безопасности колесики блокируются автоматически, когда стул не используется.

SRPSKI

Radi sigurnosti, kada se stolica ne koristi, točkići se automatski zaključavaju.

SLOVENŠČINA

Zaradi varnosti imajo kolesca zavoro, ki se samodejno vključi, ko stol ni v uporabi.

TÜRKÇE

Sandalyede kullanılmadığı zaman güvenlik nedenlerinden dolayı tekerlekler otomatik olarak kilitlenir.

中文

出于安全考虑，座椅不使用时脚轮自动锁定。

繁体

為了安全考量，座椅不使用時，輪腳會自動鎖定。

한국어

의자를 사용하지 않을 때에는 안전상의 이유로 바퀴가 자동으로 잠깁니다.

日本語

安全のため、椅子に重量がかかっていないときは、キャスターがロックされます。

BAHASA INDONESIA

Untuk alasan keselamatan roda terkunci secara otomatis ketika kursi tidak digunakan.

BAHASA MALAYSIA

Atas sebab keselamatan, roda terkunci secara automatik apabila kerusi tidak digunakan.

عربي

لأسباب تتعلق بالسلامة تغلق العجلات تلقائياً عندما لا يكون الكرسي قيد الإستخدام.

ไทย

เมื่อไม่ใช้เก้าอี้ ล้อเก้าอี้จะล็อกอัตโนมัติ เพื่อความปลอดภัย

