

16x

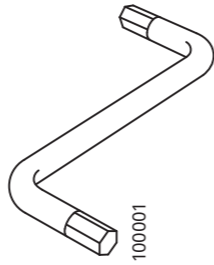

2x



2x

i

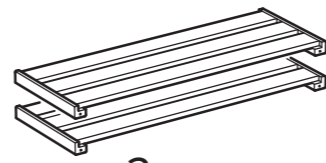

2x

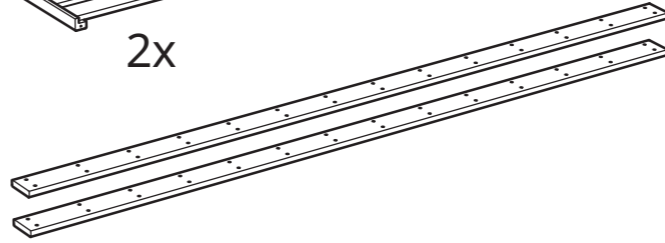

2x

# OBSERVATOR

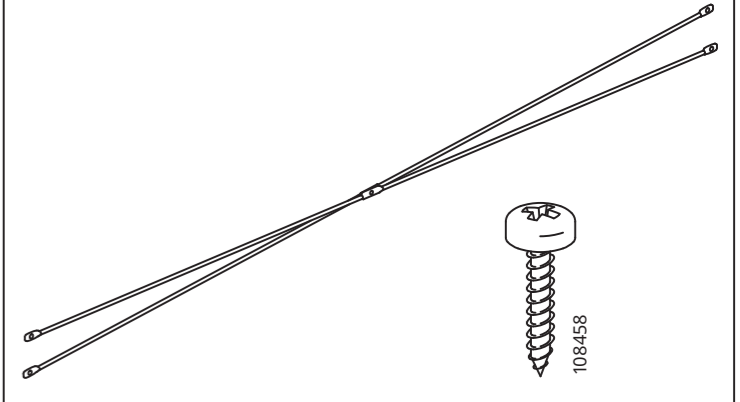

1x

4x

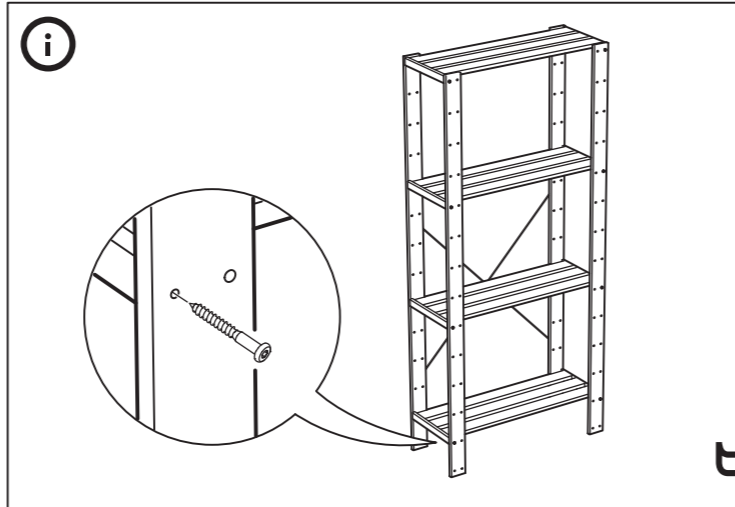
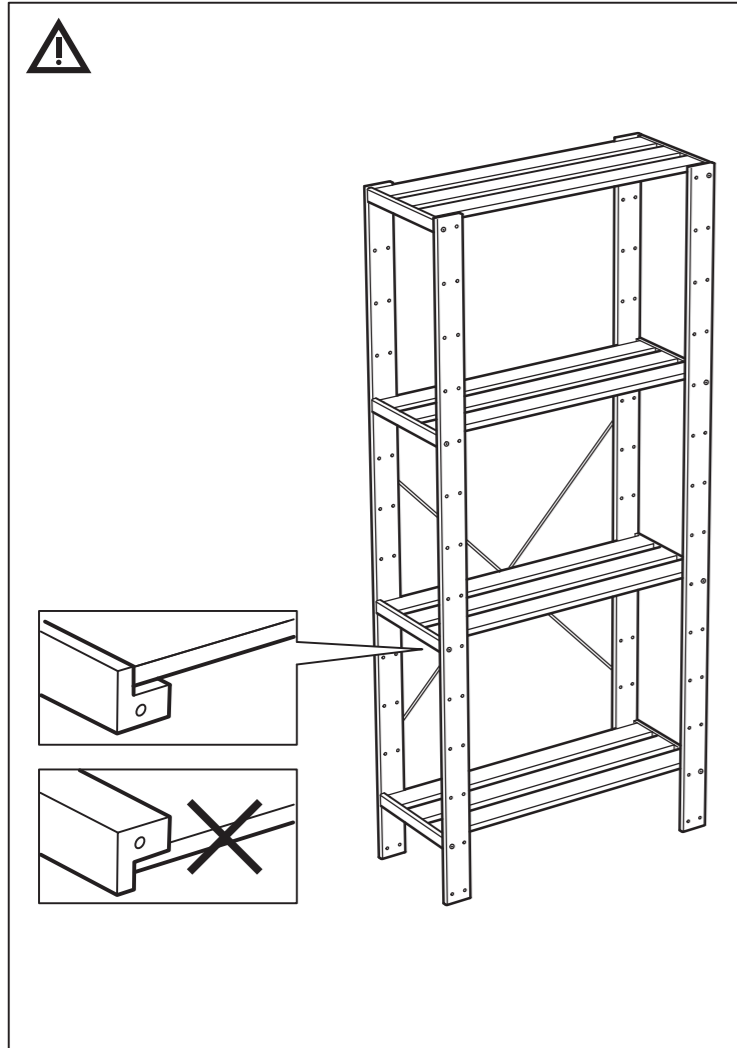

1

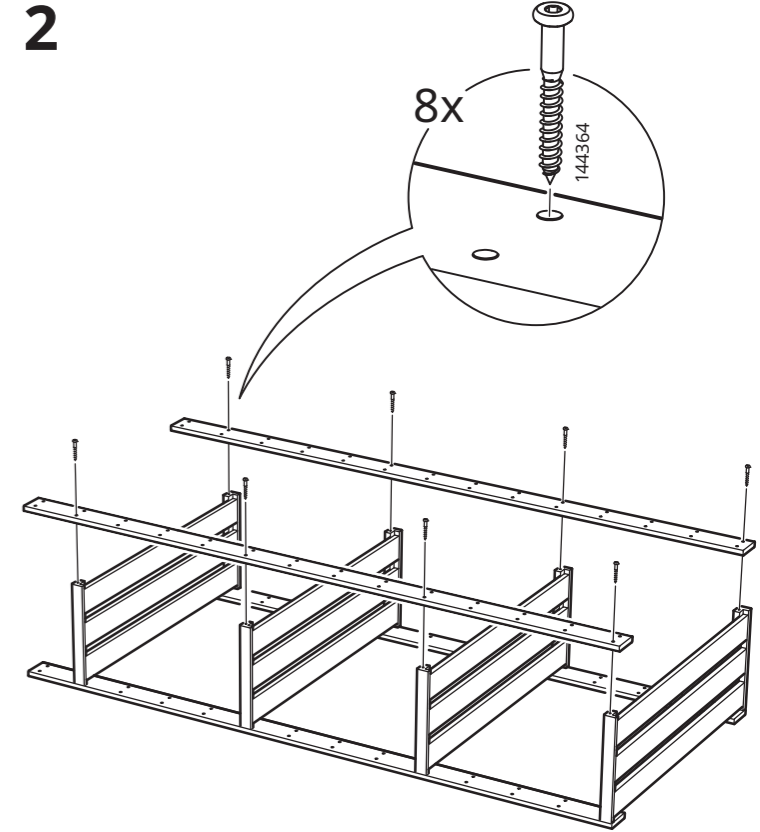
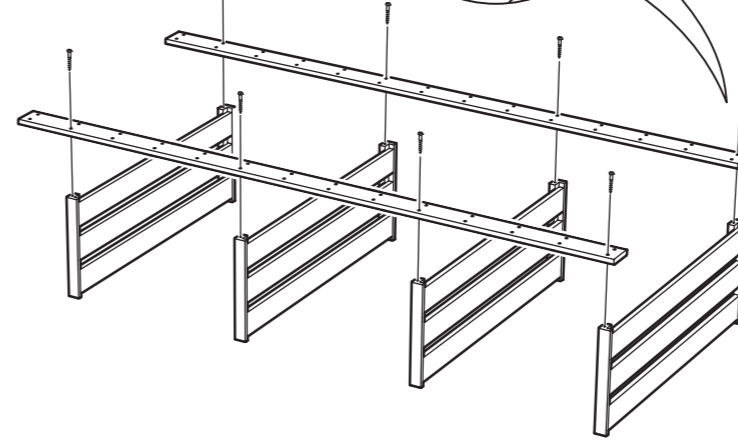
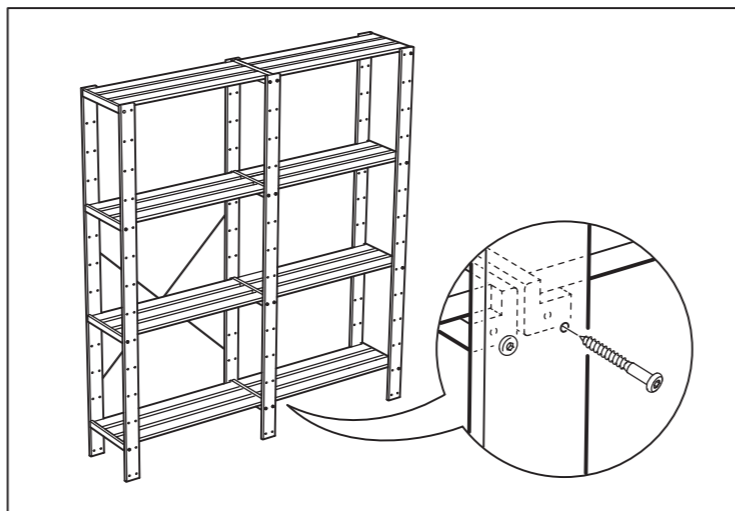

2

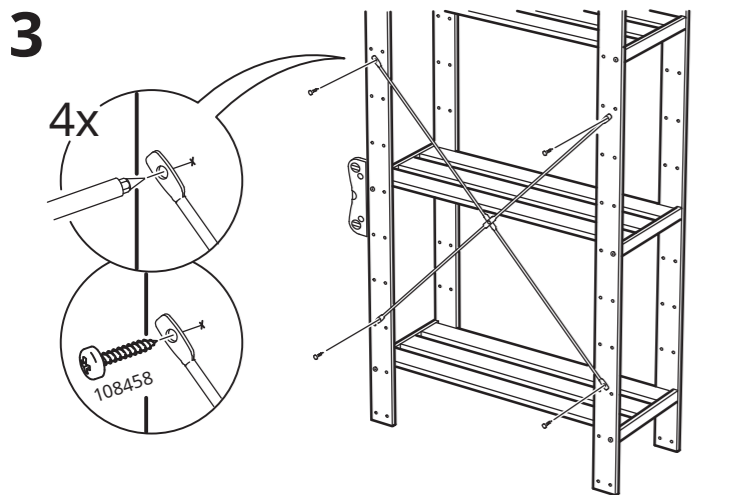

3

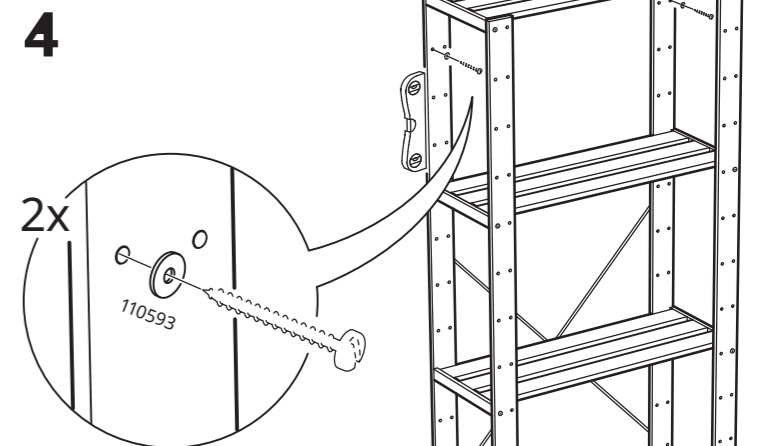
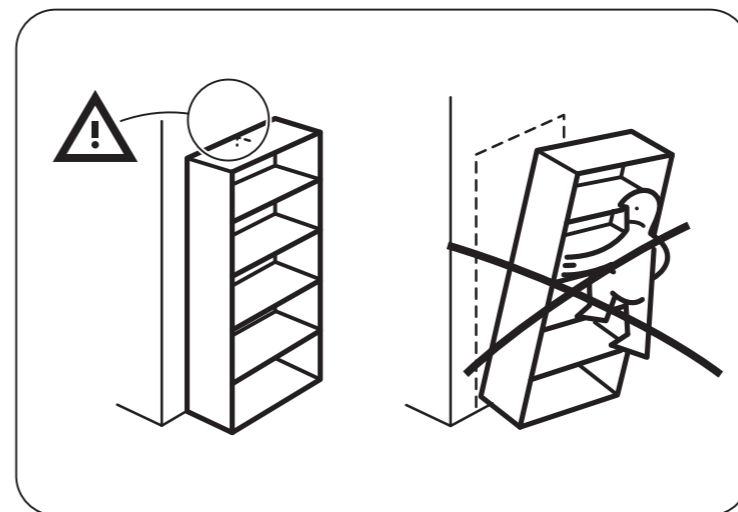
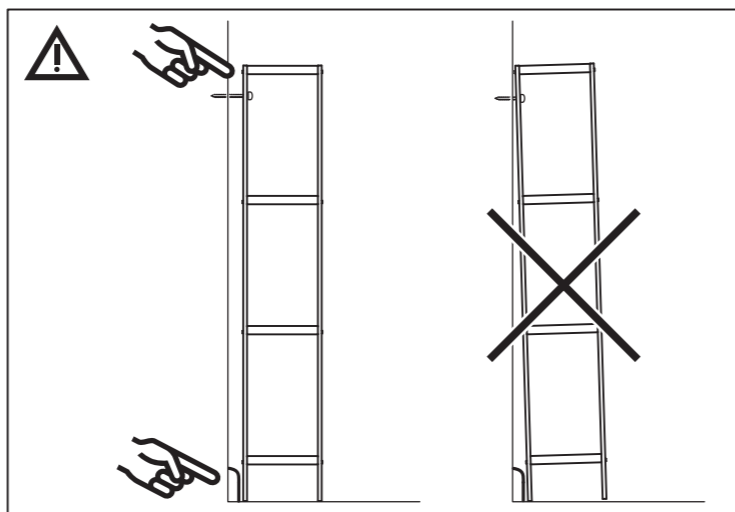

4