

HEMNES

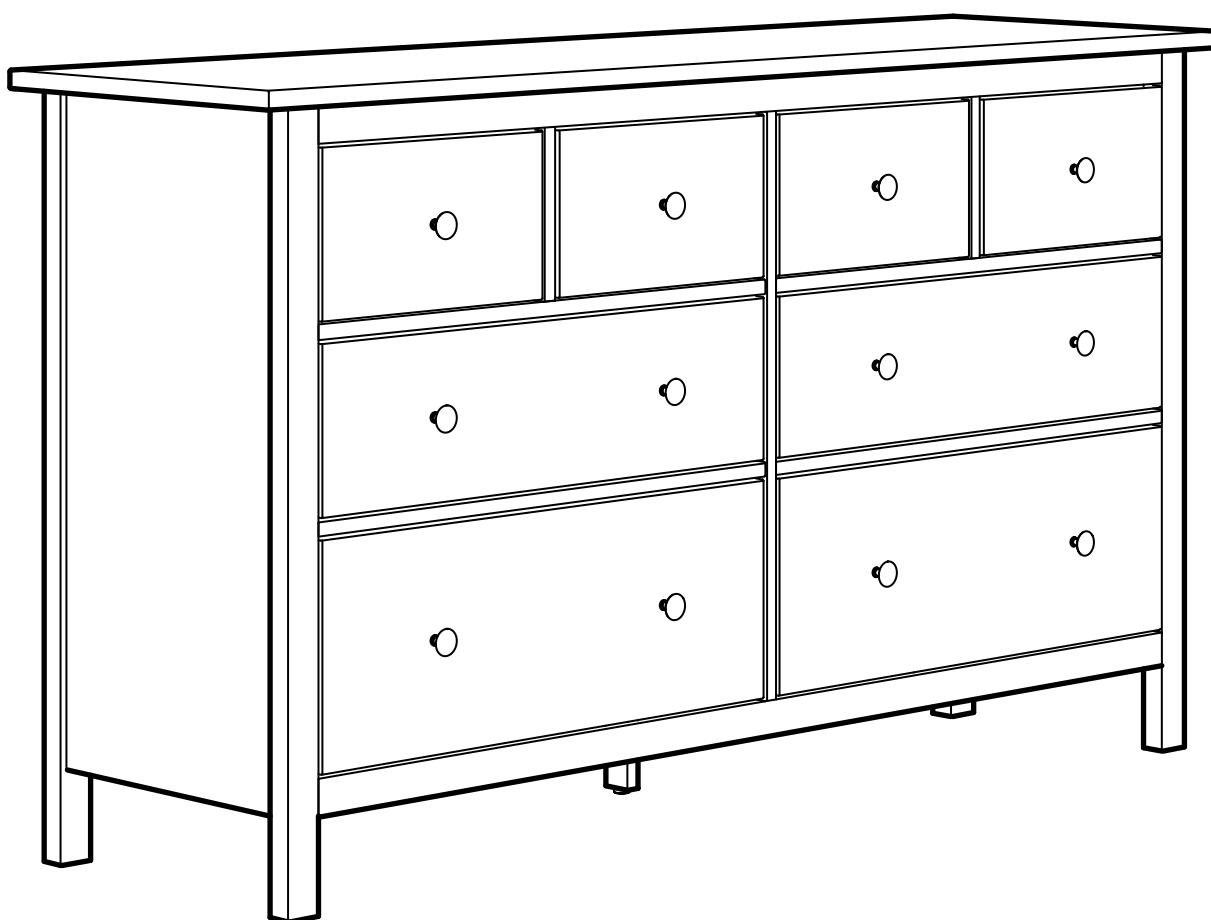

Design and Quality
IKEA of Sweden

ENGLISH

Important!

We recommend you to fix the furniture to the wall with the enclosed safety bracket to prevent it from tipping over if a child climbs or hangs on it. Different wall materials require different types of fixing devices. Use fixing devices suitable for the walls in your home (not included). If you are uncertain about what type of screw or fitting to use, please contact your hardware store. The screw which is enclosed with the safety bracket is only intended for fixing the safety bracket to the furniture.

DEUTSCH

Wichtig!

Wir empfehlen, das Produkt mit dem beigegepackten Kippschutz an der Wand zu verankern, damit es nicht kippt, falls ein Kind versucht, daran hochzuklettern oder sich daranzuhängen. Verschiedene Materialien erfordern verschiedene Arten von Befestigungsbeschlägen. Immer Befestigungsmaterial verwenden, das für die häuslichen Wände geeignet ist (nicht beigegepackt). Ggf. sollte man sich beim Eisenwarenfachhandel nach geeignetem Befestigungsmaterial erkundigen. Die beigegepackten Schrauben sind nur zum Anbringen des Kippschutzes am Möbelstück vorgesehen.

FRANÇAIS

Important !

Nous vous recommandons de fixer ce meuble au mur à l'aide du dispositif antibascule inclus afin d'éviter que le meuble ne se renverse si un enfant monte dessus ou s'y agrippe. Le type de fixation à utiliser dépend du matériau du mur. Choisissez des fixations (non incluses) adaptées à vos cloisons. Si vous avez des doutes sur le type de fixations à utiliser, contactez un vendeur spécialisé. La ferrure incluse avec le dispositif anti-basculer ne doit être utilisée que pour fixer ce dernier au meuble.

NEDERLANDS

Belangrijk!

Wij adviseren het meubel met de meegeleverde kantelbeveiliging aan de wand te bevestigen om te voorkomen dat het omvalt als een kind erop klimt of eraan gaat hangen. Verschillende materialen vereisen verschillende soorten bevestigingsbeslag. Gebruik bevestigingsbeslag dat geschikt is voor de muren in je huis (niet inbegrepen). Weet je niet zeker welk beslag geschikt is, raadpleeg de vakhandel. De schroef die is meegeleverd, is uitsluitend bedoeld om de kantelbeveiliging aan het meubel te bevestigen.

DANSK

Vigtigt!

Vi anbefaler, at møblet fastgøres til væggen med det medfølgende sikkerhedsbeslag, så det ikke vælter, hvis børn kravler eller hænger i det. Forskellige vægmateriale kræver forskellige skruer og rawlplugs. Brug de skruer og rawlplugs, der passer til væggene i dit hjem (medfølger ikke). Hvis du er i tvivl om, hvilken type skruer/rawlplugs du skal bruge, skal du kontakte et byggemarked. De skruer, der leveres sammen med sikkerhedsbeslaget, er kun beregnet til at fastgøre sikkerhedsbeslaget til møblet.

ÍSLENSKA

Mikilvægt!

Til að tryggja að húsgagnið detti ekki ef börn klifra á því, mælum við með því að það sé fest við vegg. Mismunandi veggefni krefjast mismunandi festinga. Notaðu aðeins festingar sem henta í veggina heima hjá þér (fylgja ekki). Ef þú ert ekki viss um hvers konar festingar eigi að nota ættirðu að leita ráðlegginga hjá fagmanni. Skrufan sem fylgir öryggisfestingunni er aðeins ætluð til að festa öryggisbúnaðinn við húsgagnið.

NORSK

Viktig!

Vi anbefaler at du fester møbelet til veggen med festet som er inkludert, for å hindre at det tipper over dersom et barn klatrer eller henger i det. Ulike veggmaterialer krever forskjellige festemidler. Bruk festemidler som er egnet for veggene i ditt hjem (ikke inkludert). Dersom du er usikker på hva slags skruesystem du bør bruke, kontakt en fagmann. Skruen som følger med festet er beregnet på å skru festet fast i møbelet.

SUOMI

Tärkeää!

Kaluste tulee kiinnittää seinään pakkauksessa olevalla kaatumisesteellä, jotta se ei kaadu, jos lapsi kiipeilee tai roikkuu siinä. Seinäkiinnitystarvikkeet (esim. ruuvit) myydään erikseen. Valitse ne kotisi seinämateriaalin mukaan. Apua oikeanlaisten kiinnikkeiden valintaan saat rautakaupasta. Kaatumisesteen mukana tuleva ruuvi on tarkoitettu kaatumisesteen kiinnittämiseksi huonekaluun.

SVENSKA

Viktigt!

Vi rekommenderar att möbelen fästs vid väggen med det medföljande tippskyddet för att förhindra den fråån att tippa över om ett barn klättrar eller hänger på den. Olika material kräver olika typer av fästbeslag. Använd fästbeslag som är lämpade för väggarna i ditt hem (medföljer ej). Om du är osäker på vilken typ av skruv eller beslag som skall användas, kontakta en fackhandlare. Skruven som medföljer tippskyddet är endast avsedd för att fästa tippskyddet vid möbelen med.

ČESKY

Důležité!

Doporučujeme připevnit nábytek ke stěně pomocí přiloženého kování, abyste zabránili jeho převrácení, pokud na něj budou děti šplhat. Rozdílné materiály zdi-va vyžadují různé typy uchycení. Použijte uchycení vhodné pro váš typ stěny (není součástí balení). Pokud si nejste jisti, jaký typ šroubků a hmoždinek použít, obraťte se na nejbližší železářství. Šroubek, který je součástí balení bezpečnostního kování, je určen pouze k připevnění kování k nábytku.

ESPAÑOL

¡Importante!

Recomendamos que fijas el mueble a la pared con el herraje de seguridad que se suministra para evitar que se caiga si un niño se encarama o cuelga del mismo. Los distintos materiales de pared requieren diferentes tipos de tornillos. Usa tornillos adecuados para las paredes de tu casa (no se incluyen). Si no estás seguro sobre qué tipo de clavo o herrajes se deben usar, ponte en contacto con tu ferretería. El tornillo que se incluye con el herraje de seguridad está destinado sólo para ser usado para fijar el herraje al mueble.

ITALIANO

Importante!

Fissa il mobile alla parete con l'accessorio di sicurezza incluso, per evitare che si rovesci se, per esempio, un bambino si appende o si arrampica sul mobile stesso. Pareti di materiali diversi richiedono tipi diversi di accessori di fissaggio. Usa sempre accessori di fissaggio (da acquistare a parte) adatti alle pareti della tua casa. Se hai dubbi, rivolgiti a un rivenditore specializzato. Le viti fornite con l'accessorio di sicurezza devono essere usate esclusivamente per fissare l'accessorio al mobile.

MAGYAR

Fontos!

Javasoljuk, hogy a bútort rögzítsd a falhoz a mellékelt biztonsági konzollal, hogy ne borulhasson fel, ha egy kisgyerek rámászik, vagy rákapaszkodik. Az egyes faltípusokhoz más-más rögzítő alkatrészek szükségesek. Az otthoni faltípusnak megfelelő rögzítőket használj (a csomag nem tartalmazza). Ha bizonytalan vagy, milyen csavarok kellenek, fordulj szakemberhez. A csomagban mellékelt csavarokat csak a biztonsági konzol bútorhoz való rögzítéséhez használd.

POLSKI

Ważne!

Zalecamy przymocowane mebla do ściany za pomocą dołączonego wspornika zabezpieczającego, aby zapobiec przewróceniu się, gdyby dziecko wspięło się na mebel lub na nim zawiesiło. Różne materiały, z których wykonane są ściany, wymagają różnego rodzaju mocowań. Użyj okuc mocujących odpowiednich dla rodzaju ścian w Twoim domu (nie są dołączone do zestawu). Jeśli nie masz pewności, jaki rodzaj śruby lub mocowania należy użyć, zasięgnij porady w swoim sklepie z narzędziami. Śruba dołączona do wspornika zabezpieczającego jest przeznaczona wyłącznie do mocowania wspornika do mebla.

EESTI

Tähtis!

Soovitame kinnitada mööbel seinale kaasasolevate ohutusulguritega, et ennetada mööbli ümber kukkumist kui laps ronib või ripub sellel. Erinevate seinamaterjalide tõttu kasutatakse eri liiki kinnitusvahendeid. Kasutage sobivaid kinnitusvahendeid (need ei kuulu komplekti). Täpsema informatsiooni saamiseks võtke ühendust kohaliku tööriistapoega. Komplektis olev kinnitusvahend sobib ainult ohutusulguri kinnitamiseks.

LATVIEŠU

Svarīgi!

Šo mēbeli ieteicams piestiprināt pie sienas ar komplektā iekļauto aizsargbalstu, lai tā neapgāztos otrādi, ja uz tās rāpjas vai karājas bērns. Stiprinājumi jāizvēlas atkarībā no sienu materiāla. Vienmēr izvēlieties stiprinājumus (komplektā nav iekļauti), kas ir piemēroti konkrētajam sienu materiālam jūsu mājoklī. Ja neesat pārliecināti, kādas skrūves vai stiprinājumus izmantot, konsultējieties ar būvniecības speciālistu vai veikalu. Skrūve, kas iekļauta komplektā ar aizsargbalstu, paredzēta aizsargbalsta piestiprināšanai pie mēbeles.

LIETUVIŲ

Svarbu!

Rekomenduojame pridiedama apsaugine gembe tvirtinti baldus prie sienos, kad jie nenukristų, jei kartais vaikas sumanytų ant jų užlipti ar pakybti. Skirtingoms sienų apdailos medžiagoms reikalingos skirtingų tipų tvirtinimo priemonės. Pasirinkite jas pagal savo namų sienas (nepriededamos). Jei kyla abejonių, kreipkitės į vietos statybinių medžiagų pardavėją. Pridiedamas prie apsauginės gembės varžtas skirtas tik tvirtinti ją prie baldų.

PORTUGUÊS

Importante!

Recomendamos fixar o móvel à parede com o suporte de segurança incluído a fim de evitar que caia sobre uma criança, caso esta decida trepar ou pendurar-se no móvel. Os diferentes materiais de parede requerem diferentes tipos de fixação. Utilize as ferragens adequadas para as paredes da sua casa (não incluídas). Se não tem a certeza sobre que tipo de ferragens deve usar, contacte a sua loja de ferragens habitual. As ferragens incluídas juntamente com o suporte de segurança são apropriadas apenas para fixar o suporte ao móvel (e não à parede).

ROMÂNĂ

Important!

Se recomandă fixarea mobilierului de perete cu ajutorul consolei incluse pentru a preveni răsturnarea acestuia în cazul în care este escaladat de un copil. Pereții sunt realizați din materiale diferite, așa dar, necesită diferite tipuri de mecanisme de fixare. Folosește-le pe cele potrivite materialului din care sunt construiți pereții casei tale (vândute separat). Dacă nu ești sigur ce tip de șurub sau mecanism să folosești, contactează un specialist. Șurubul care se vinde împreună cu consola de siguranță se folosește numai pentru prinderea acesteia de piesa de mobilier.

SLOVENSKY

Dôležití!

Nábytok odporúčame pripevniť k stene pomocou priloženej bezpečnostnej konzoly, aby ste zabránili jeho prevráteniu, keď sa naňho budú šplhať deti. Rozličné materiály stien si vyžadujú rôzne typy uchytenia. Použite uchytenie vhodné pre váš typ steny (nie je súčasťou balenia). Ak si nie ste istí aký typ skrutiek alebo uchytenia použiť, kontaktujte najbližšie železiarstvo. Skrutka, ktorá je priložená k bezpečnostnej konzole, je určená iba na pripevnenie konzoly k nábytku.

БЪЛГАРСКИ

Важно!

Препоръчваме да закрепите този артикул за стената с приложената скоба, за да предотвратите пракатурването му, ако дете се опита да се покатери или увеси на него. Различните материали на стените изискват различни монтажни средства. Използвайте монтажни средства, подходящи за стените в дома си (не са включени в комплекта). Ако не сте сигурни какви аксесоари да използвате, свържете се с железарски магазин. Винтът, приложен към скобата, е за прикрепянето ѝ към този артикул.

HRVATSKI

Važno!

Preporučuje se da namještaj pričvrstite na zid priloženim sigurnosnim nosačem kako biste spriječili prevrtanje ako se dijete vješa ili penje na namještaj. Različite vrste zidova zahtijevaju različite vrste pričvrstnika. Koristite pričvrstnike koji odgovaraju vrsti vašeg zida (nisu priloženi). Ako niste sigurni koju vrstu vijka ili okova koristiti, kontaktirajte lokalnu prodavaonicu alata.

ΕΛΛΗΝΙΚΑ

Προσοχή!

Συνιστάται η στερέωση του επίπλου στον τοίχο με το βραχίονα ασφαλείας που εσωκλείεται για την αποφυγή κάθε κινδύνου σε περίπτωση που το παιδί σας σκαρφαλώσει στο έπιπλο. Κάθε τοίχος απαιτεί διαφορετικό τύπο συστημάτων στερέωσης. Χρησιμοποιήστε συστήματα στερέωσης κατάλληλα για τους τοίχους του σπιτιού σας (πωλούνται χωριστά). Εάν δεν είστε σίγουροι για τις βίδες ή τα εξαρτήματα που πρέπει να χρησιμοποιηθούν, παρακαλούμε επικοινωνήστε με ένα τοπικό κατάστημα. Η βίδα που εσωκλείεται με το βραχίονα ασφαλείας προορίζεται μόνο για τη στερέωση του βραχίονα στο έπιπλο.

РУССКИЙ

Внимание!

Мебель рекомендуется крепить к стене с помощью прилагаемого крепежа без опасности, чтобы мебель не опрокинулась, если ребенок попытается на нее залезть или повиснуть. Для различного типа стен требуются различные виды креплений. Всегда выбирайте крепежные средства (не прилагаются), которые подходят к материалу ваших стен. Если вы не уверены, какой тип креплений подходит к вашим стенам, обратитесь в специализированный магазин. Прилагаемый шуруп предназначен только для фиксации крепежа безопасности к мебели.

SRPSKI

Važno!

Preporučujemo vam da nameštaj fiksirate za zid sigurnosnim spojnicama koje ste dobili uz proizvod da biste spriječili prevrtanje ako se dete popne ili okači o njega. Različiti zidni materijali zahtevaju različite tipove fiksatora. Upotrebite fiksatore odgovarajuće vrsti zida koji imate (ne dobijaju se uz proizvod). Ukoliko niste sigurni kakav tip zavrtnja ili spone treba da upotrebite, pitajte prodavca. Zavrtnaj koji dobijate uz sigurnosnu spojnicu služi isključivo za to da tu spojnicu fiksirate za nameštaj.

SLOVENŠČINA

POMEMBNO!

Svetujemo vam, da pohištvo pritrdite na steno s priloženim nosilcem, saj s tem preprečite morebitno prevračanje tega, če se nanj povzpne otrok. Ker se stenski materiali razlikujejo, zidni vložki in vijaki niso priloženi. Uporabite vijake in zidne vložke, ki so primerni za stenske materiale v vašem domu. Če niste prepričani katere vijake in zidne vložke uporabiti, se obrnite na najbližjo prodajalno z gradbenim materialom in orodjem.

TÜRKÇE

Önemli!

Mobilyanın, çocukların tırmanma veya asılmalarından dolayı devrilmesini önlemek için ürün paketinde mevcut olan emniyet aparatı ile duvara sabitletmesini tavsiye ederiz. Farklı duvar materyalleri farklı türde bağlanta parçaları gerektirir. Evinizdeki duvarlara uygun bağlanta parçaları kullanınız (ürüne dahil değildir). Hangi tip vida veya bağlanta parçalarını kullanacağınız konusunda emin değilseniz en yakın nalbur veya yapı marketlerle irtibata geçiniz. Ürün içerisinde mevcut olan vidalar ise sadece emniyet aparatını mobilyaya sabitlemek için üretilmişlerdir.

中文

重要提醒！

我们建议您使用附带的安全托架将家具固定在墙上，避免倾侧事故，或者孩子攀爬、悬挂在家具上时发生意外。不同的墙体材料需使用不同的固定装置，请使用适合您家墙面的固定装置（须另购）。如果您不确定自家墙面应使用何种类型的螺丝或固定装置，请联系本地五金店。安全托架内包含的螺丝仅用于将安全托架固定于家具上。

繁體

重要資訊！

建議以產品附帶的支撐架將家具固定在牆面上，以免小朋友因攀爬而導致家具傾倒。不同材質的牆壁需使用不同種類的上牆配件。請選用適合家中牆壁的螺絲（需另購）。若有挑選螺絲或配件的相關問題，請洽詢當地五金行。支撐架所附的螺絲只適合將支撐架固定在家具上。

한국어

중요!

어린이가 가구에 올라가거나 매달렸을 때 가구가 넘어지지 않도록 제품에 포함된 안전 브래킷으로 가구를 벽에 고정해 주세요. 벽 소재에 따라 필요한 고정장치가 다르기 때문에 벽 고정장치는 제품에 포함되어 있지 않습니다. 벽 소재에 적합한 고정장치를 사용하세요. 필요한 경우, 전문가에게 문의해 주세요. 안전 브래킷에 포함된 나사는 안전 브래킷을 가구에 고정하기 위한 나사입니다.

日本語

重要！

お子さまが家具によじ登ったりぶら下がったりしても転倒しないよう、付属の安全金具で家具を壁にしっかりと固定してください。壁の材質により使用できるネジの種類が異なるため、専用の取り付けネジは含まれていません。壁の材質に適したネジを使用してください。取り付けに適したネジに関しては、お近くの専門店にご相談ください。付属のネジは、家具に安全金具を取り付けるためのものです。

BAHASA INDONESIA

Penting!

Kami merekomendasikan anda untuk melengkapi perabot ini ke dinding dengan braket pengaman untuk mencegah terbalik jika anak memanjat atau bergantung di atasnya. Bahan dinding yang berbeda membutuhkan perangkat yang berbeda. Gunakan perangkat yang cocok untuk dinding di rumah anda (tidak termasuk). Jika anda tidak yakin tentang apa jenis sekrup atau perangkat untuk digunakan, silakan hubungi toko hardware anda. Sekrup yang disertakan dengan braket pengaman hanya ditujukan untuk memperbaiki braket keselamatan untuk furnitur.

BAHASA MALAYSIA

Penting!

Kami mengesyorkan anda melekapkan perabot ini ke dinding menggunakan pendakap keselamatan yang disertakan untuk mengelakkan perabot rebah jika kanak-kanak memanjat atau bergayut pada perabot ini. Bahan dinding yang berbeza memerlukan alat lekapan yang berbeza. Gunakan alat lekapan yang sesuai untuk dinding di kediaman anda (tidak disertakan). Jika anda kurang pasti tentang jenis skru atau lekapan yang harus digunakan, sila hubungi gedung perkakasan anda. Skru yang disertakan bersama pendakap keselamatan dikhaskan untuk memasang pendakap tersebut kepada perabot sahaja.

عربي

هام!

ننصحك بتثبيت هذا الأثاث على الحائط بواسطة حامل الأمان المرفق لمنعه من الانقلاب في حال صعد أو تعلق عليه أحد الأطفال. تتطلب مواد الحائط المختلفة أنواعاً مختلفة من أدوات التثبيت. استخدم أدوات التثبيت المناسبة للحائط في منزلك (وإذا كنت غير متأكد من نوعية المسامير أو أدوات التثبيت التي يمكنك استخدامها، يرجى الإتصال بمحل متخصص. المسامير المرفقة مع حامل الأمان مخصصة فقط لتثبيت حامل الأمان على الأثاث.

ไทย

ข้อมูลสำคัญ!

เพื่อความปลอดภัยของเด็ก ต้องยึดเตียงติดผนังด้วยอุปกรณ์ที่ให้มา เพื่อป้องกันเตียงพลิกหรือล้มลงมาหากเด็กปีนหรือโหน วัสดุผนังแต่ละแบบต้องใช้สกรูยึดต่างชนิดกัน ควรเลือกใช้สกรูที่เหมาะสมกับผนัง หากไม่มั่นใจว่าต้องใช้สกรูชนิดใด สามารถสอบถามได้ที่ร้านจำหน่ายอุปกรณ์ใกล้บ้าน สกรูที่ให้มาใช้สำหรับยึดติดกับเตียงเท่านั้น ส่วนสกรูที่ใช้ยึดเตียงติดกับผนังไม่ได้ให้มาด้วย

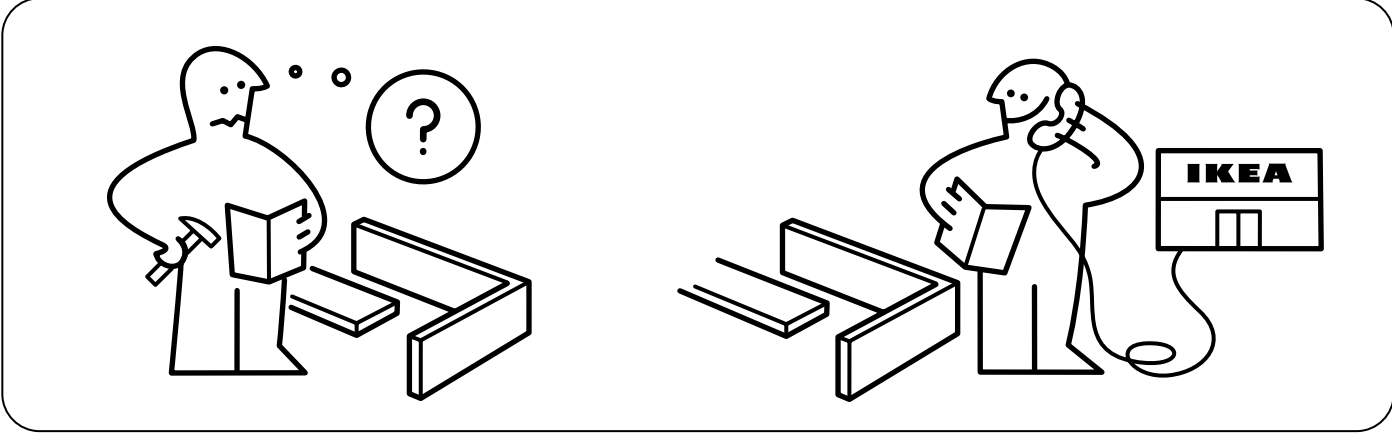
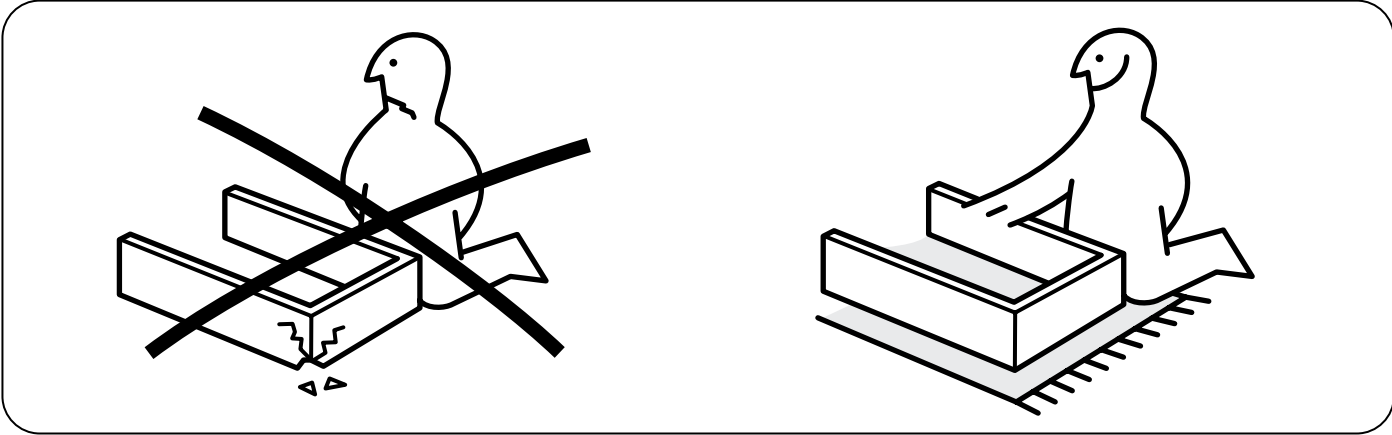
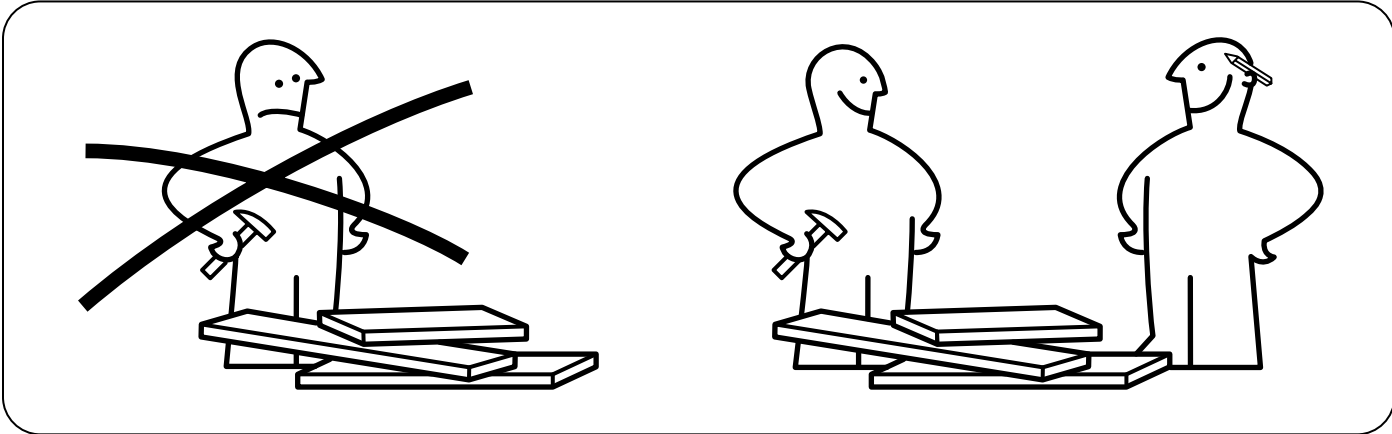
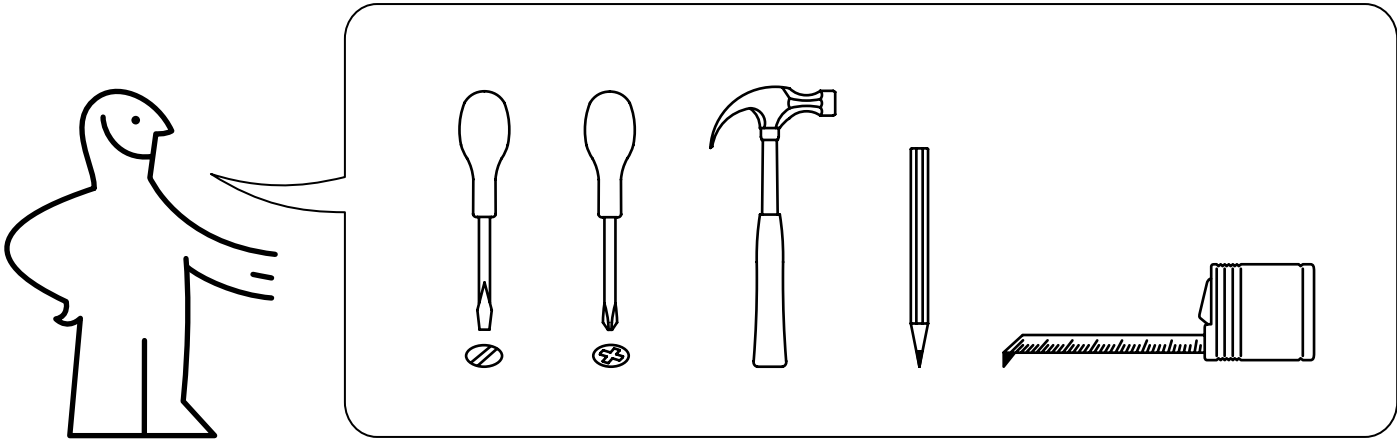

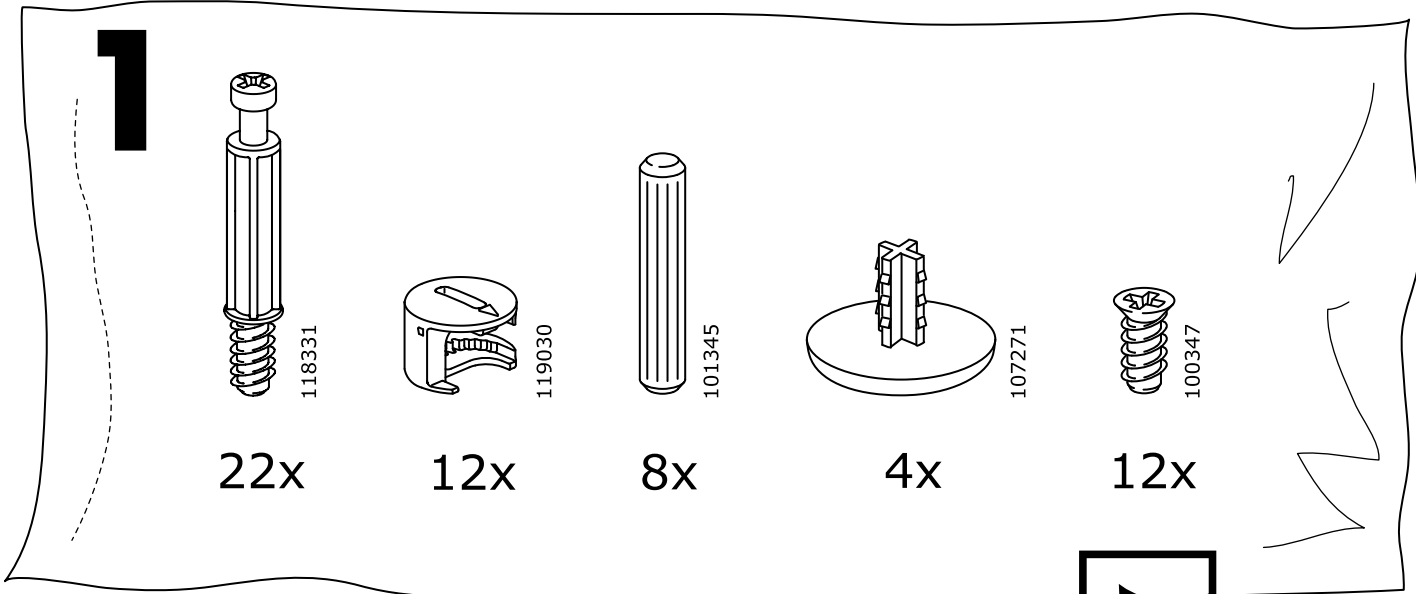
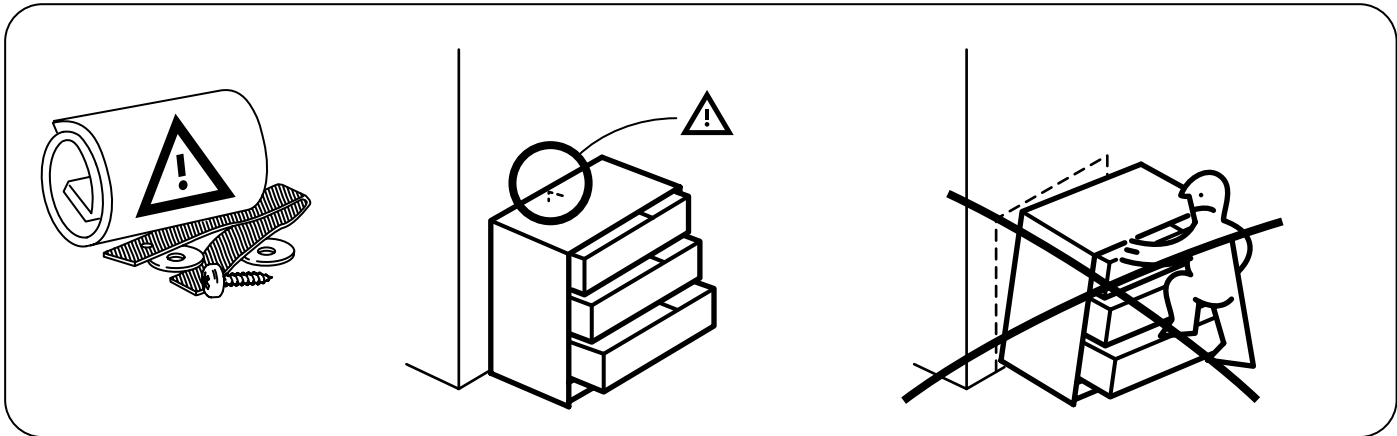

2



26x

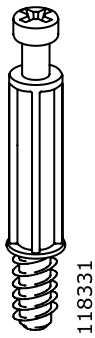

11x



4x

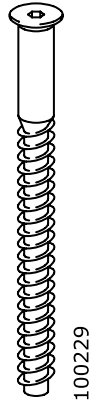

7x

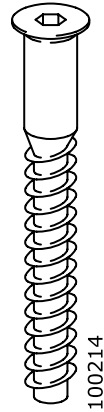

4x

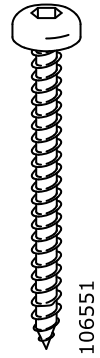

4x



2x

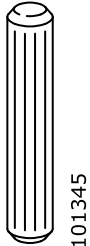

25x

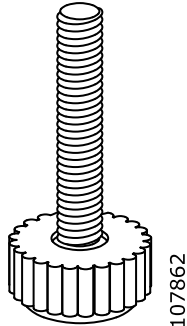

1x

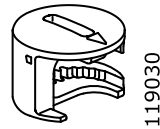

25x

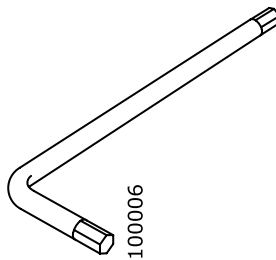

1x

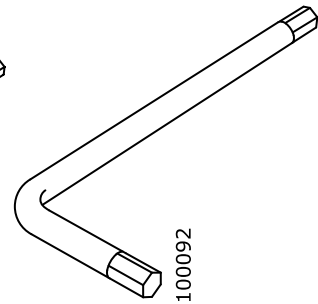

1x

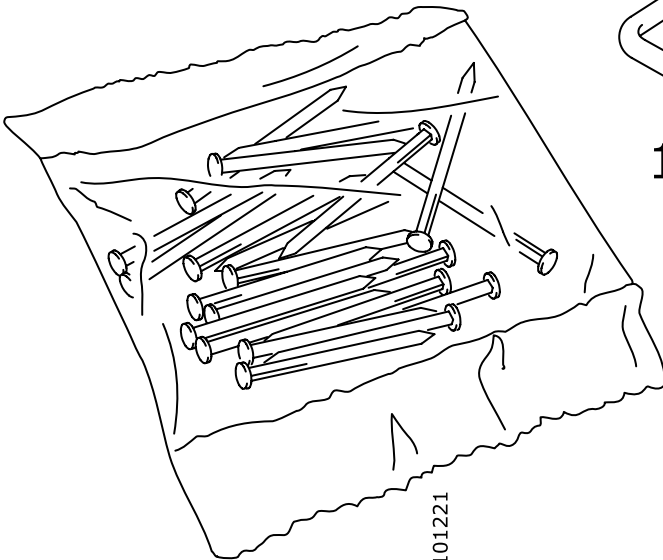

1x

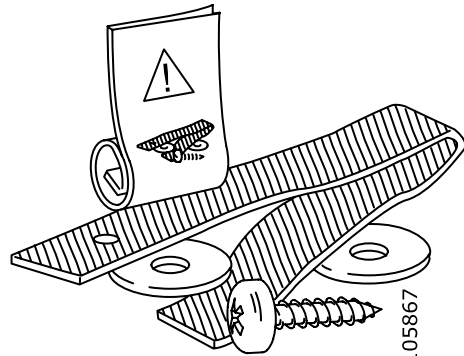

1x

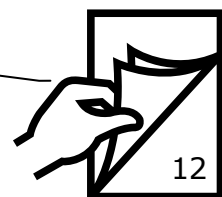

12

3

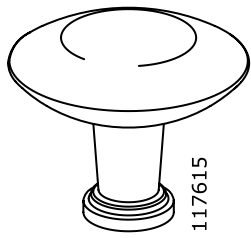

117615

12x



101345

32x

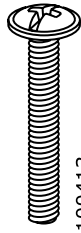

100413

12x

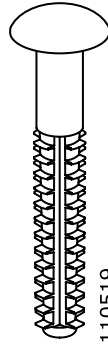

110519

48x

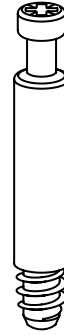

123492

32x

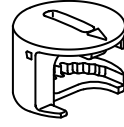

119030

32x



100365

32x



29

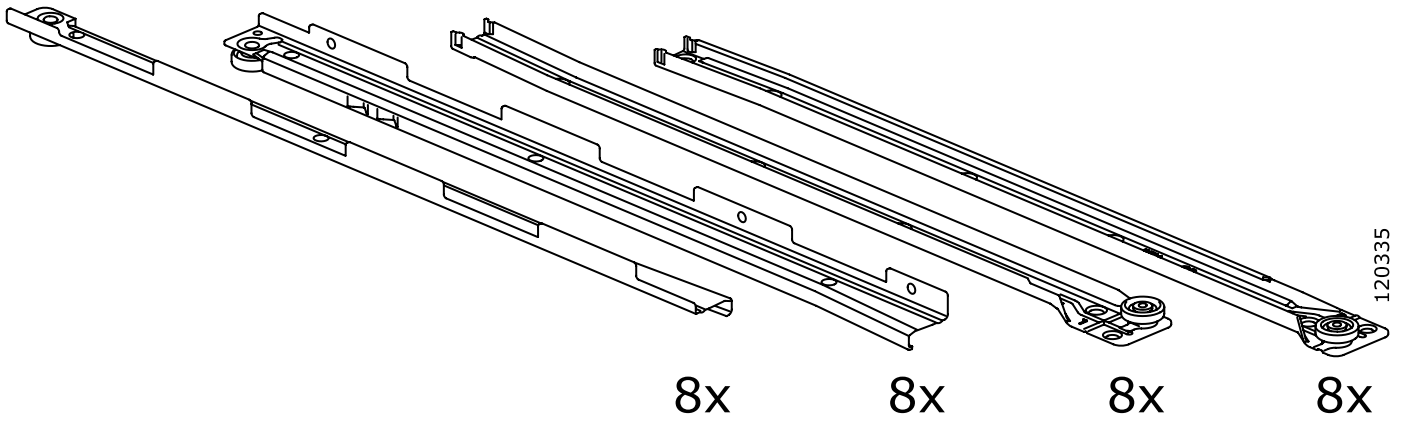

120335

8x

8x

8x

8x

1

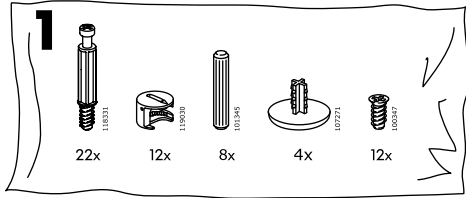

12x

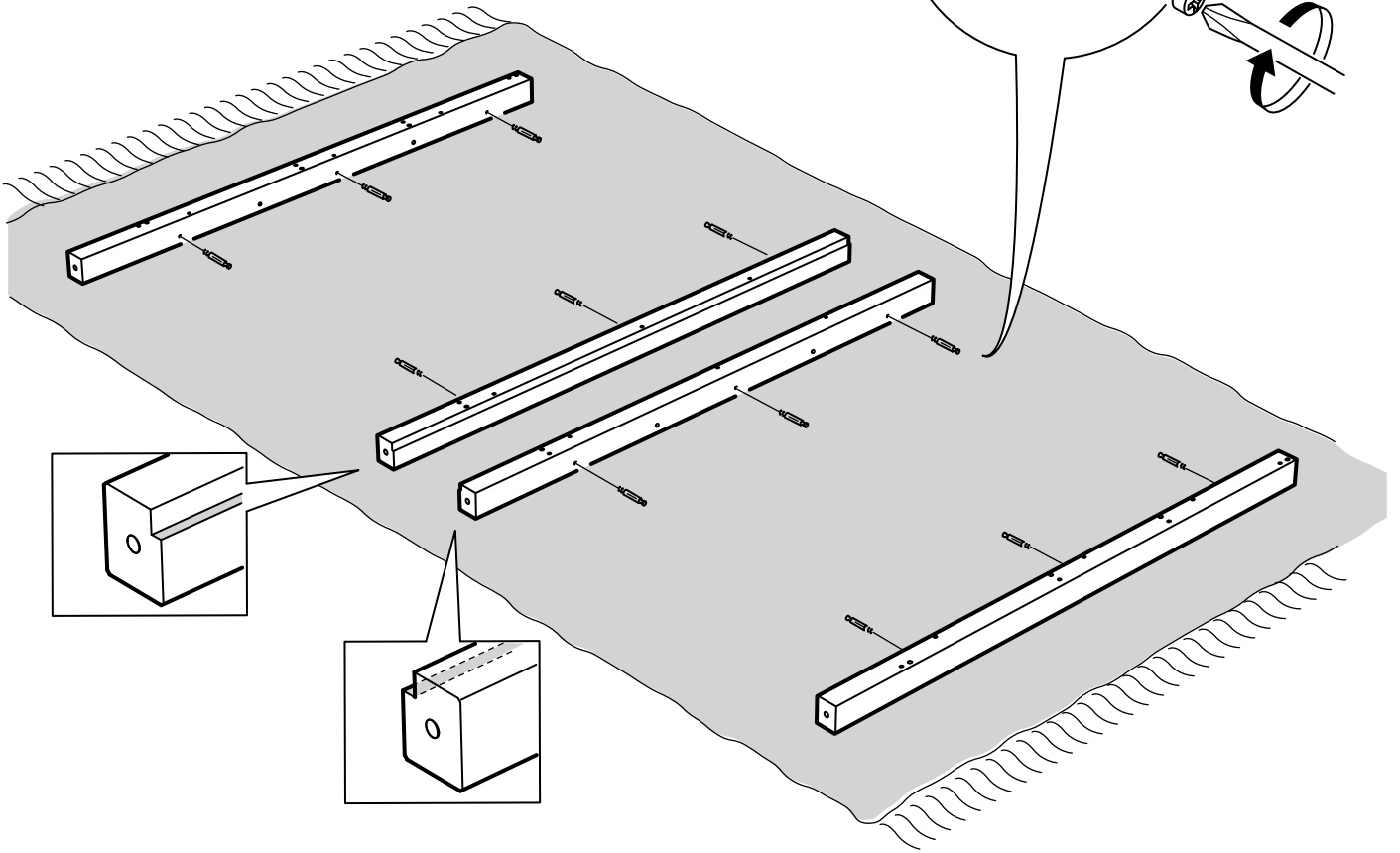
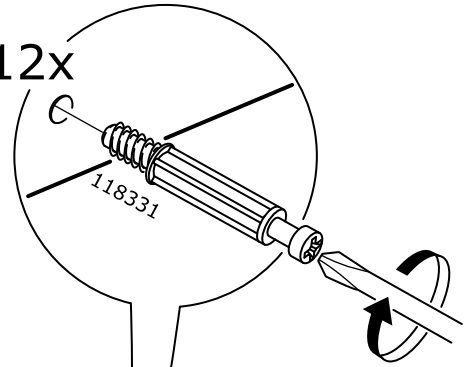

2

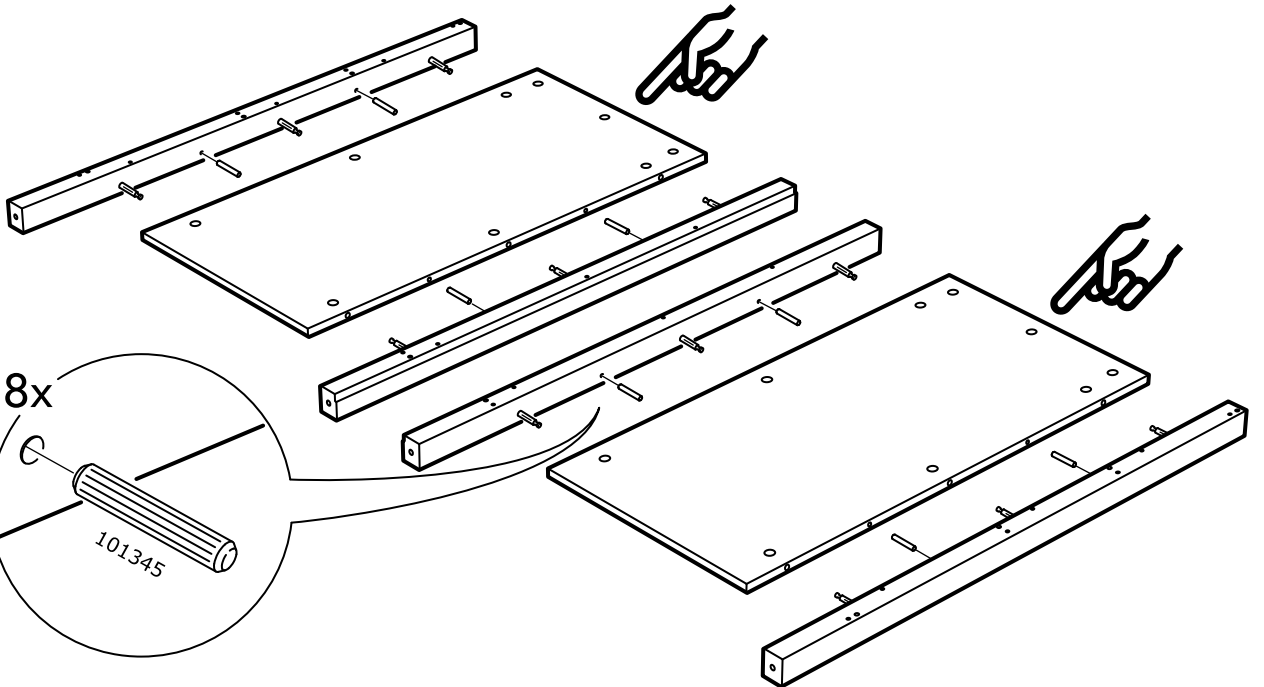

3

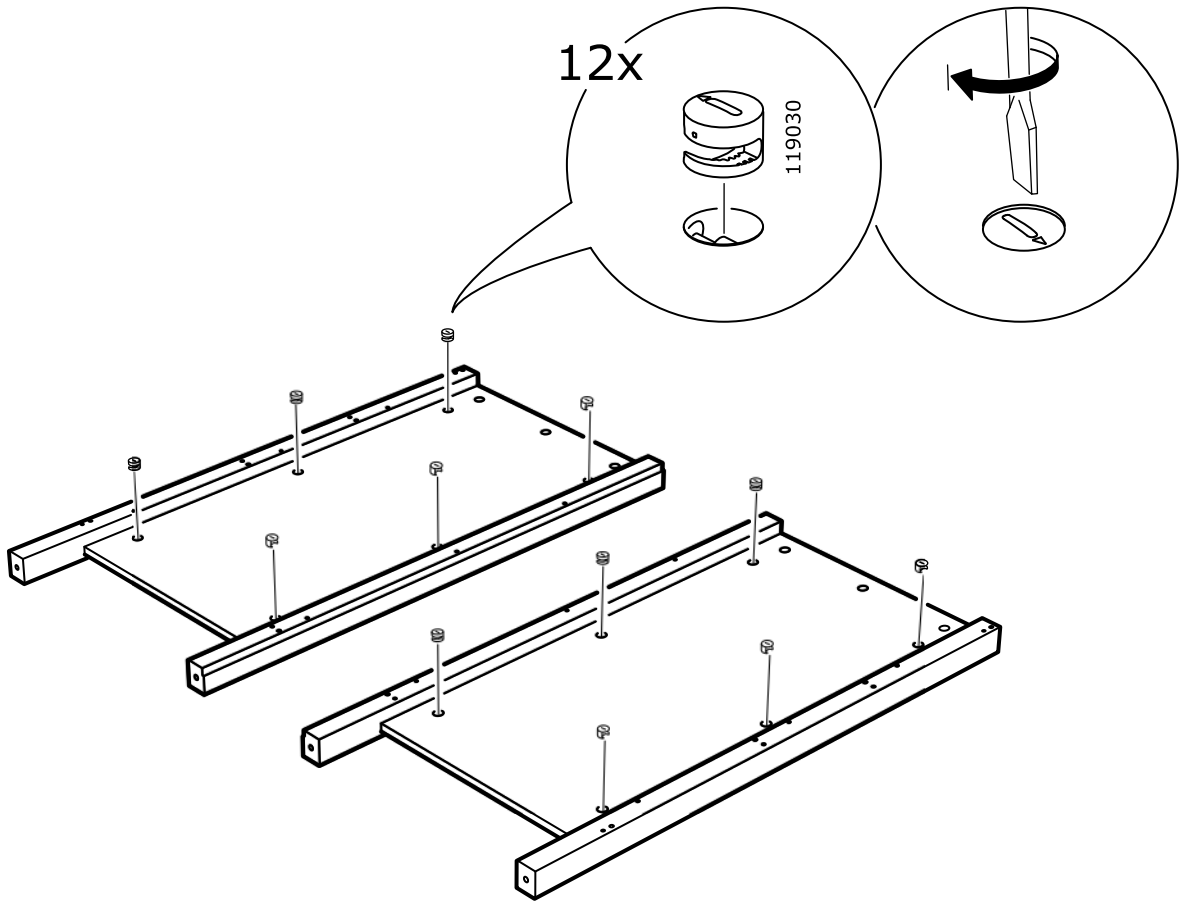

4

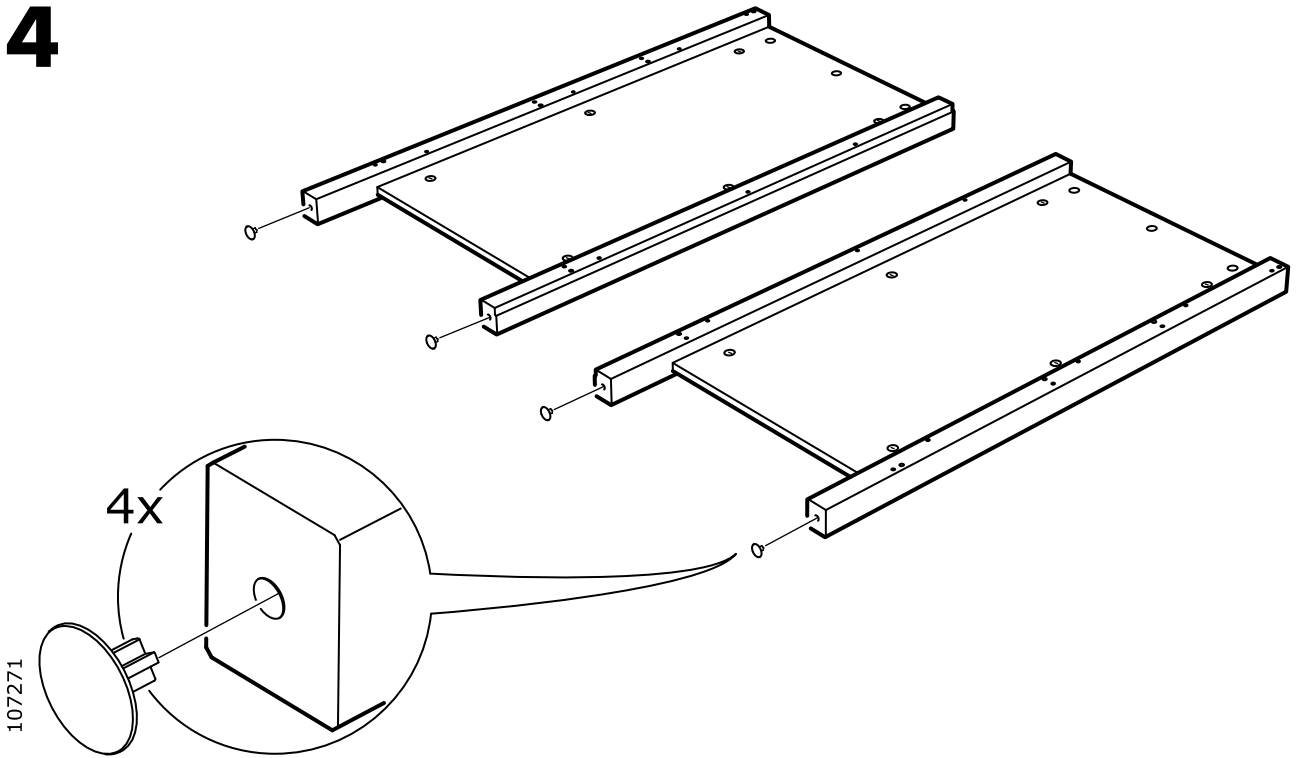

5

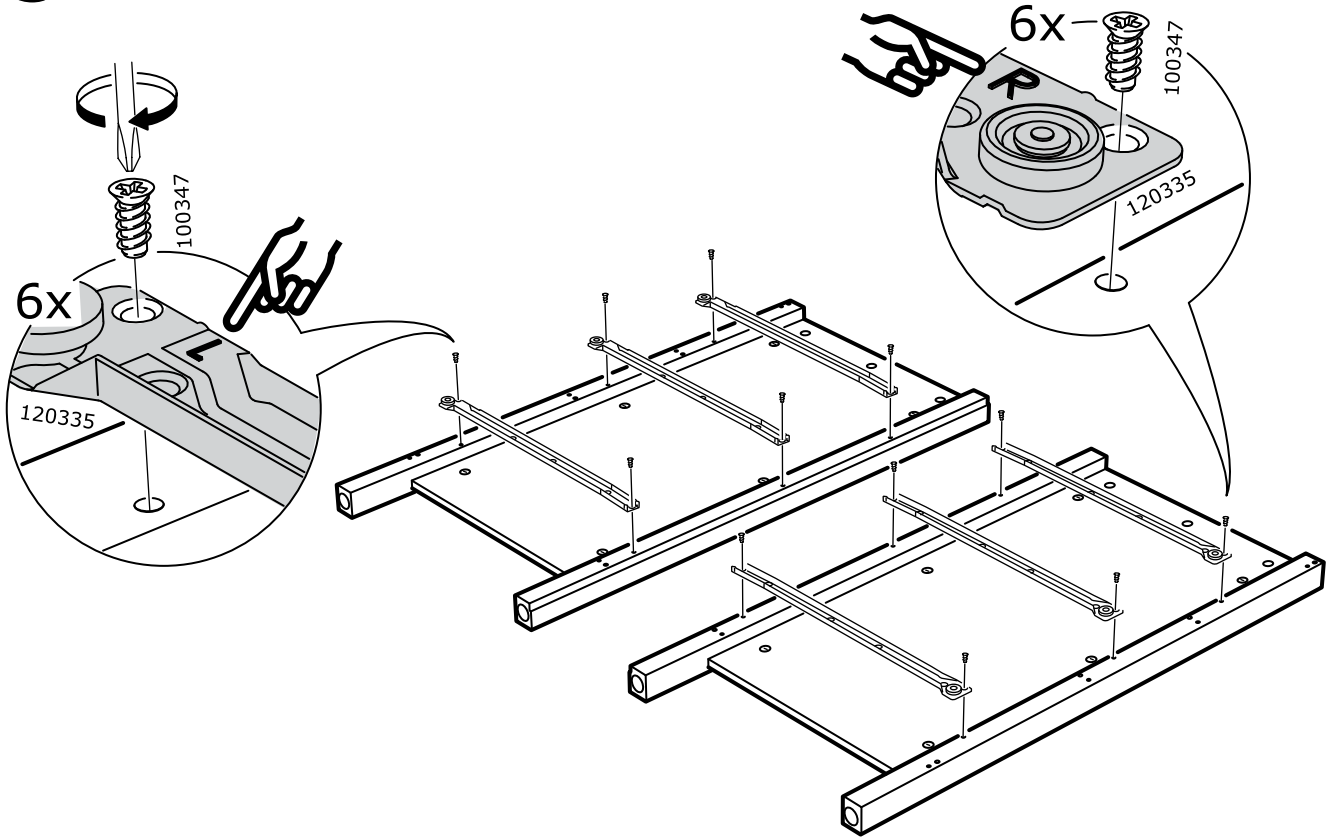

6

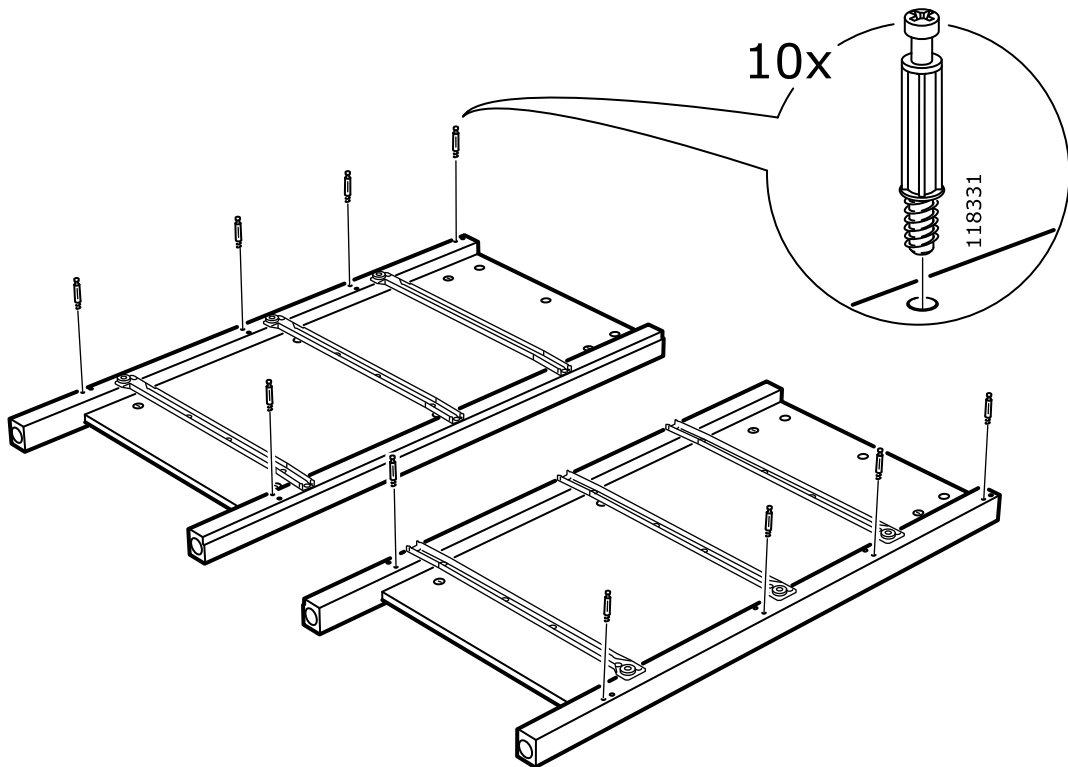

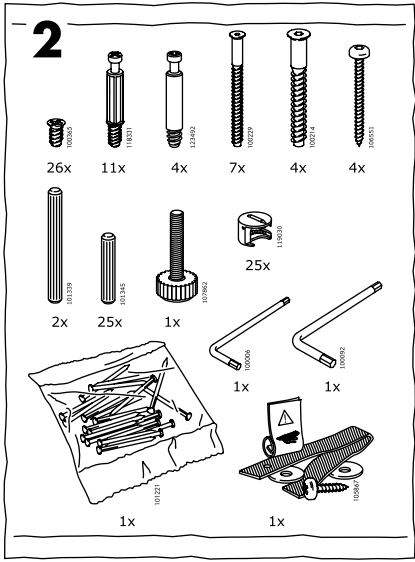

7

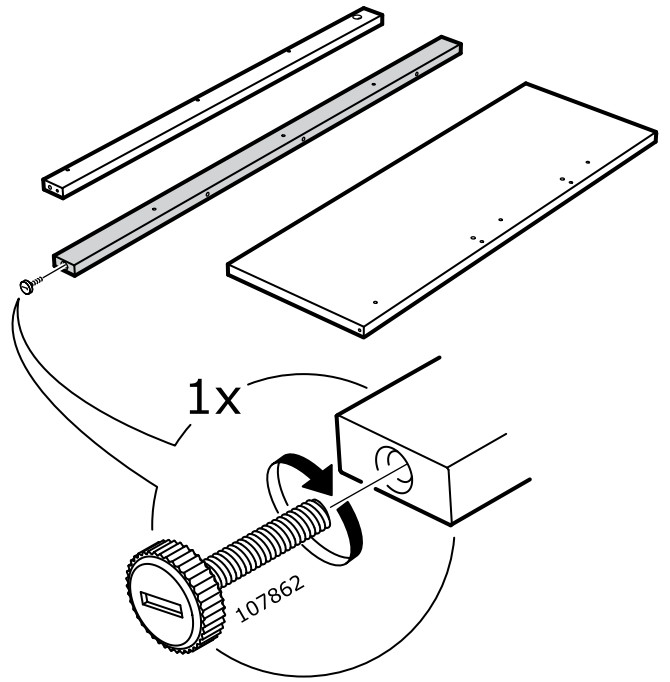

8

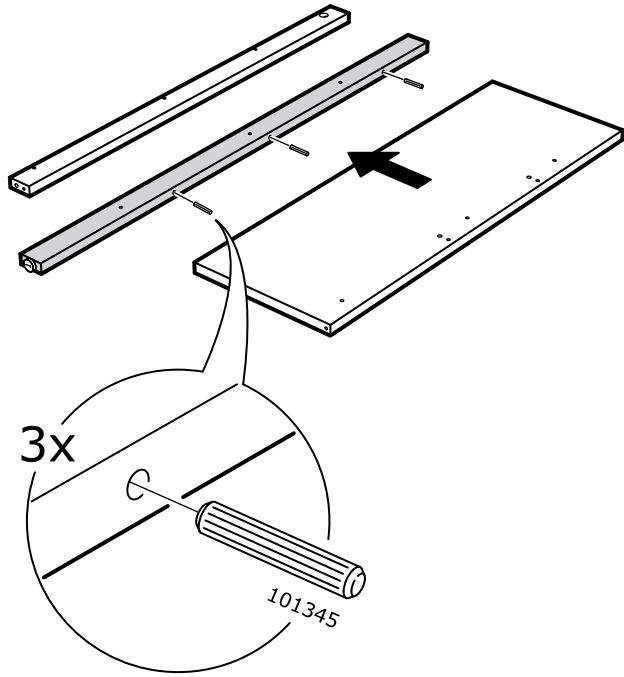

9

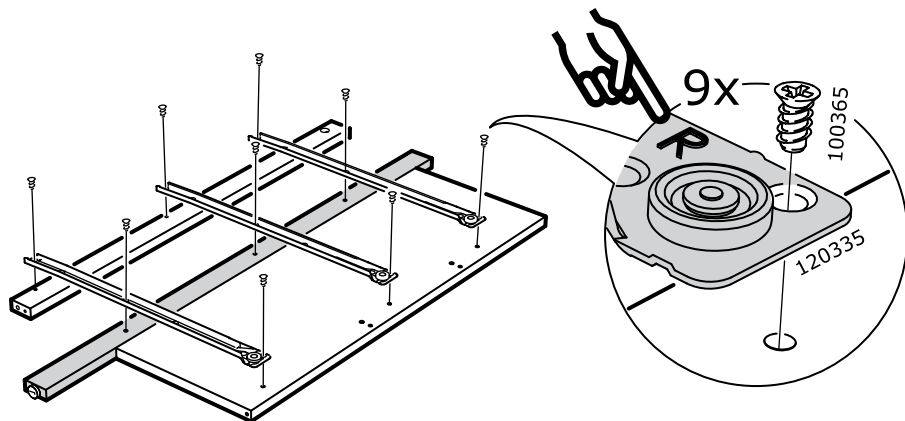

10

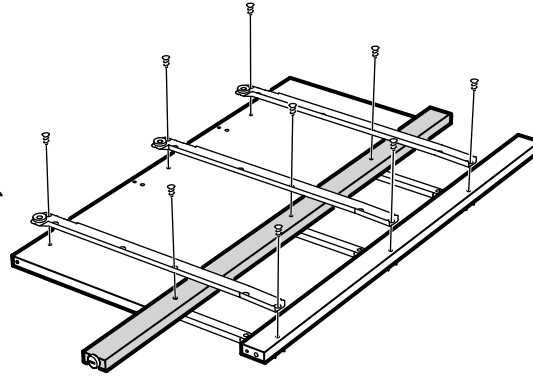
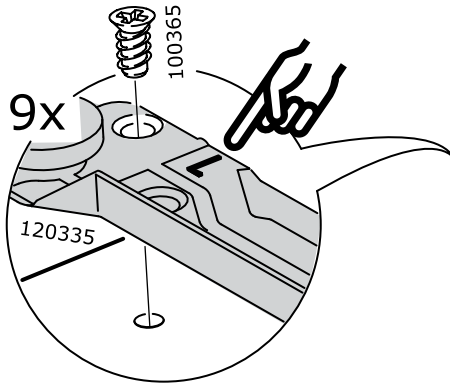
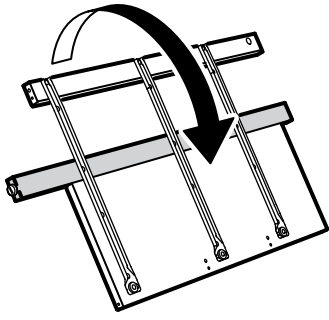

11

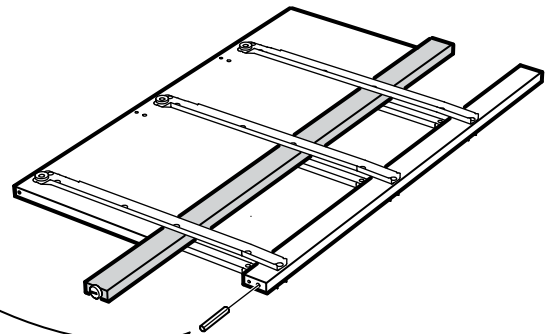
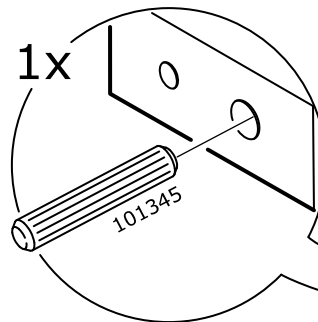
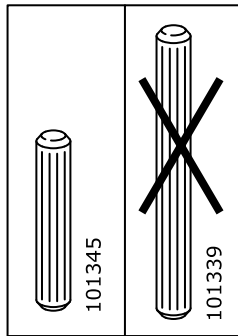

12

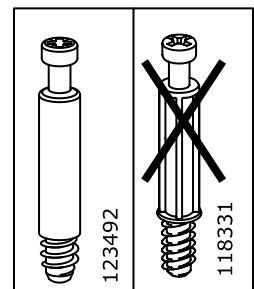
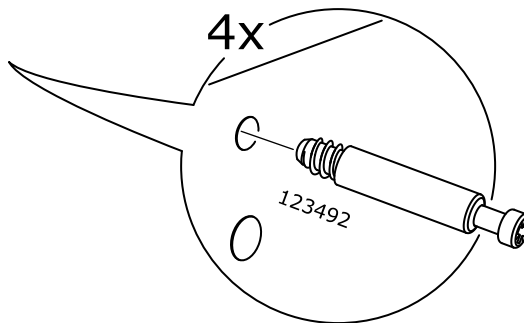
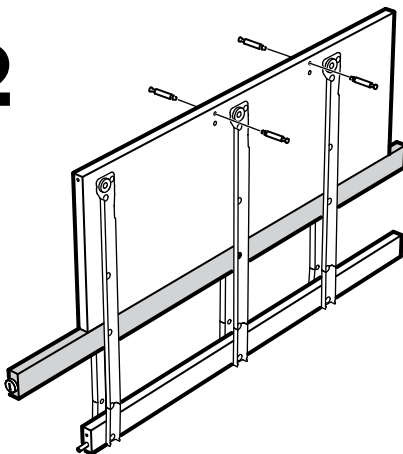

13

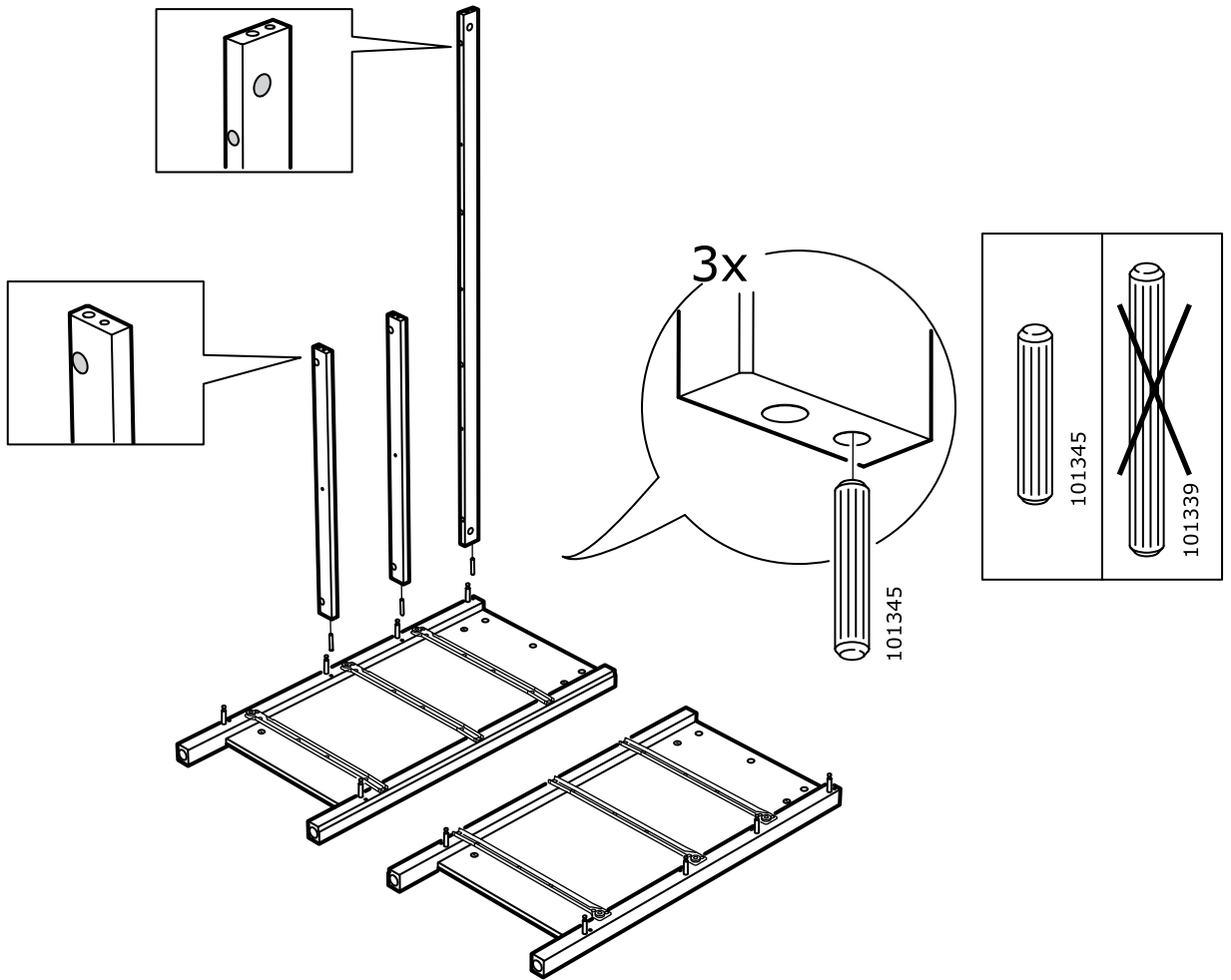

14

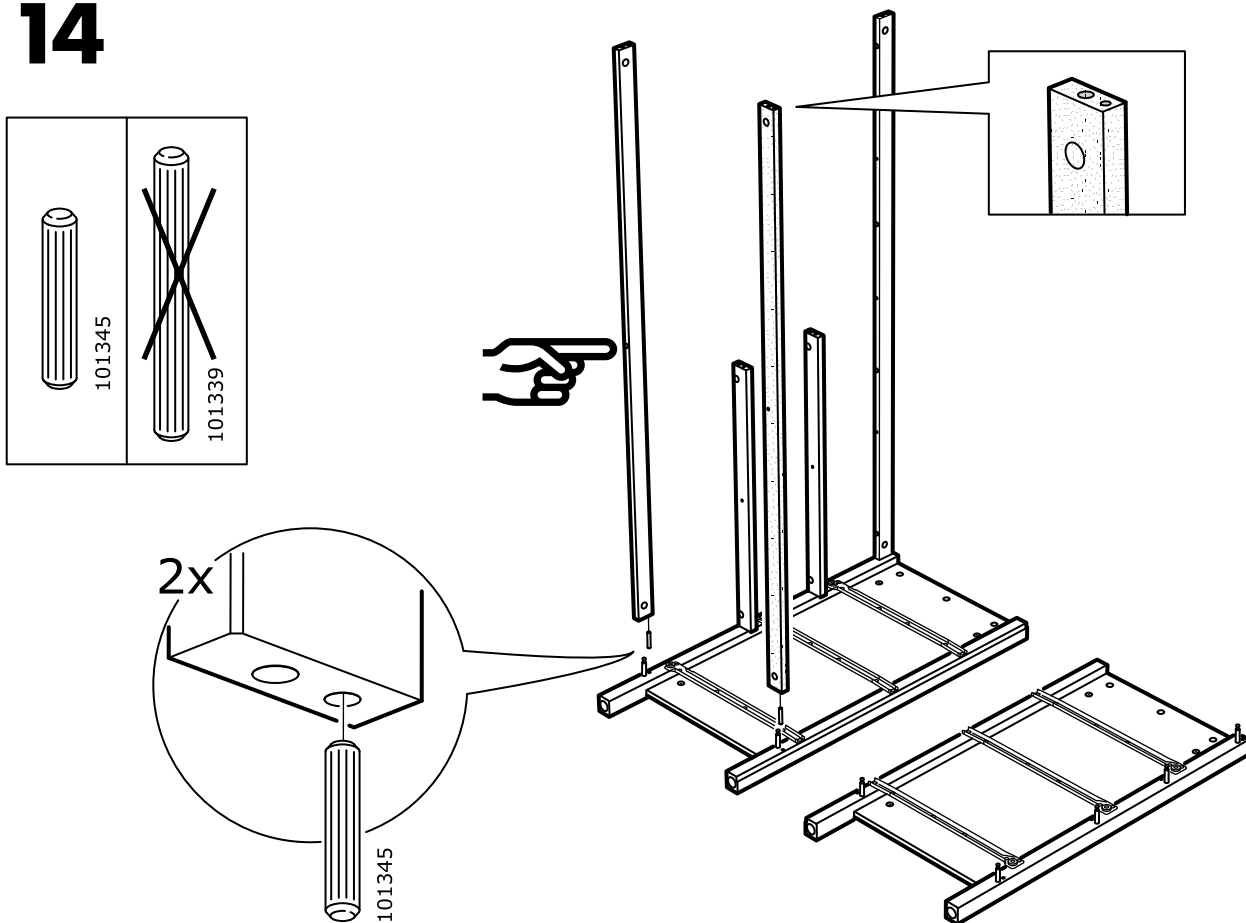

15

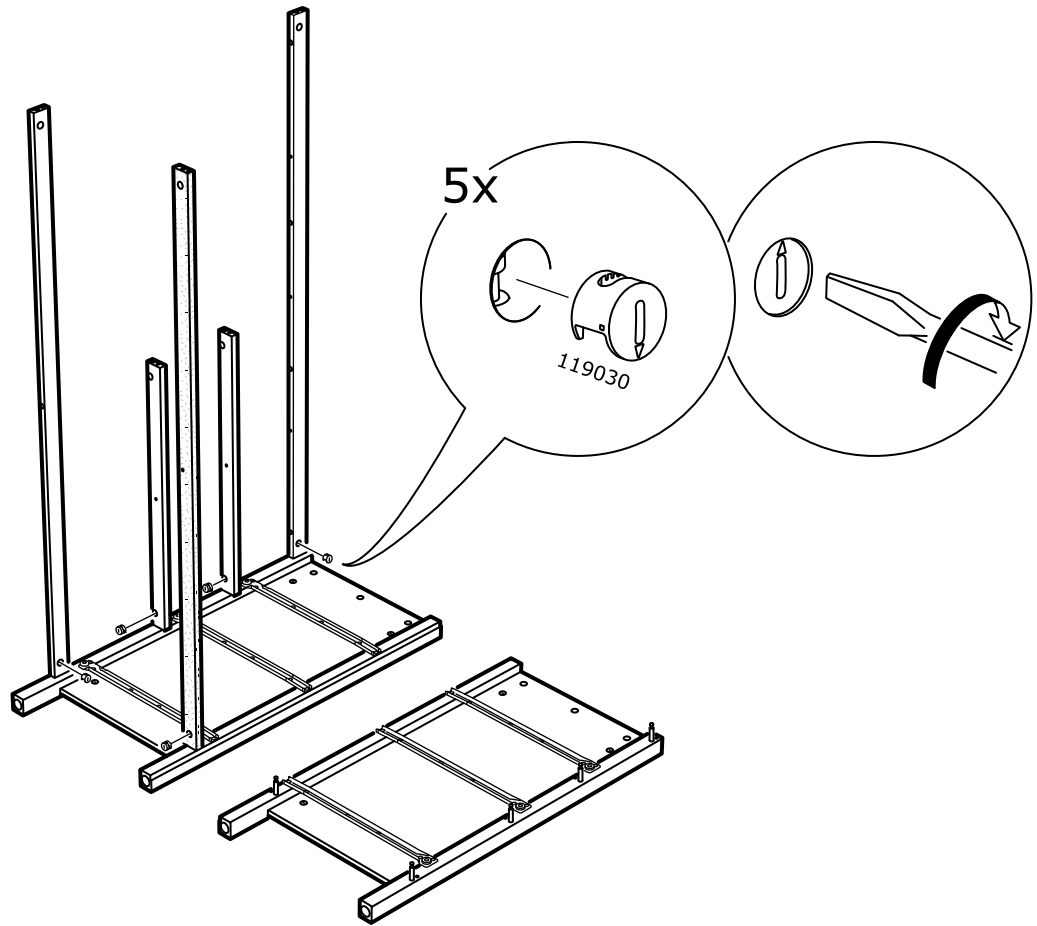

16

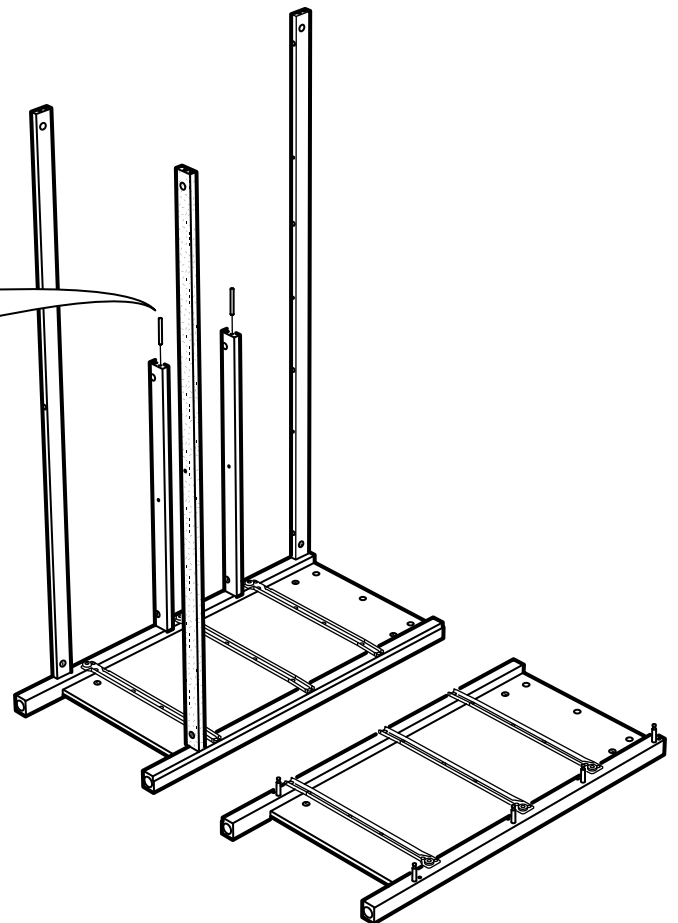
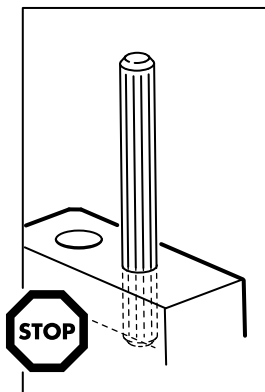
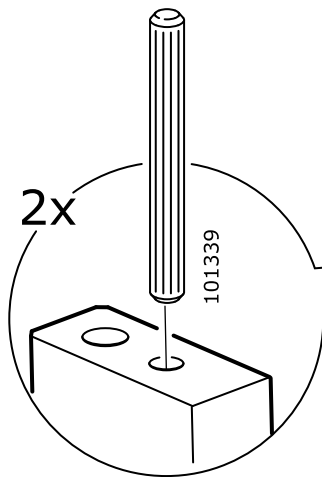
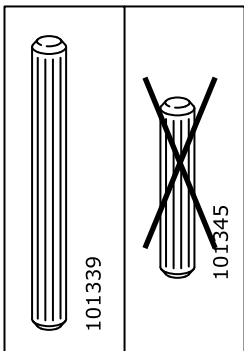

17

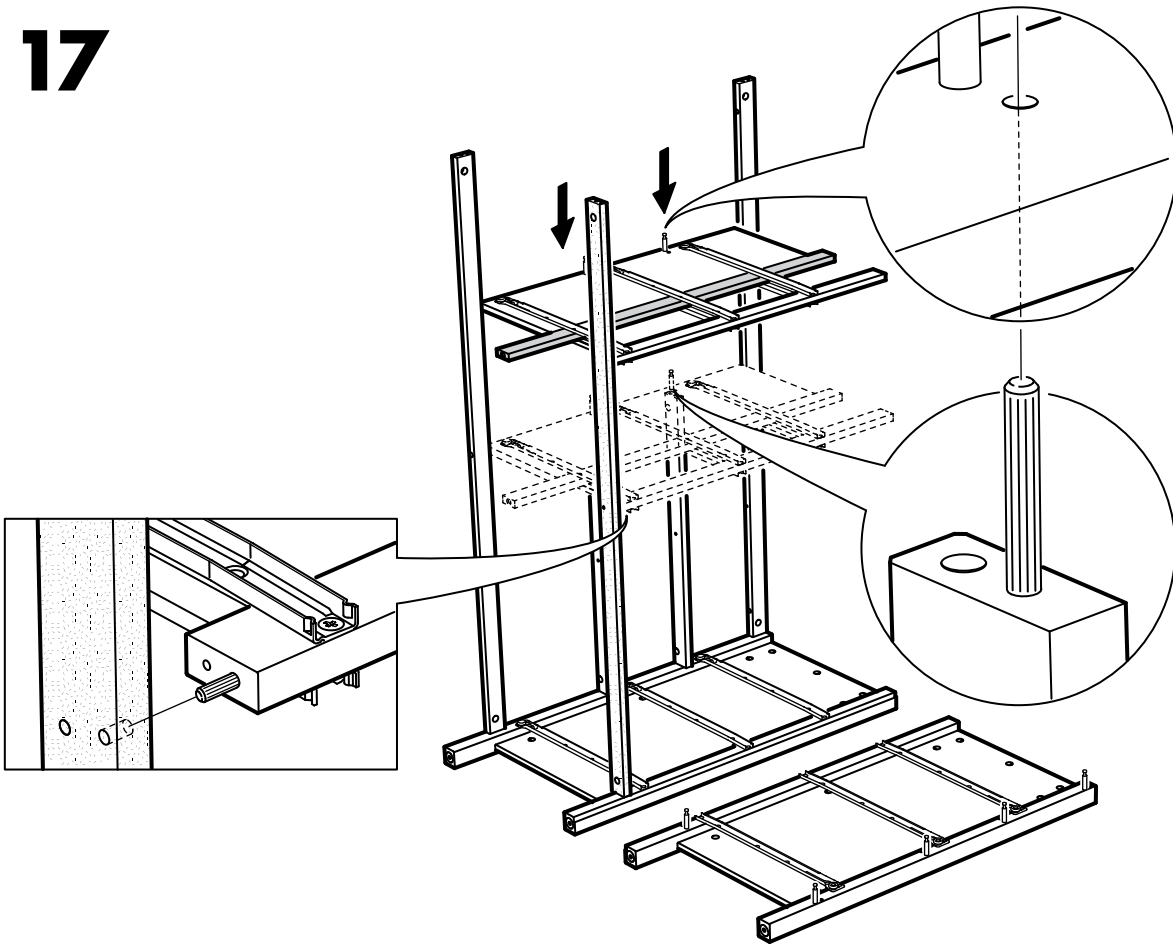

18

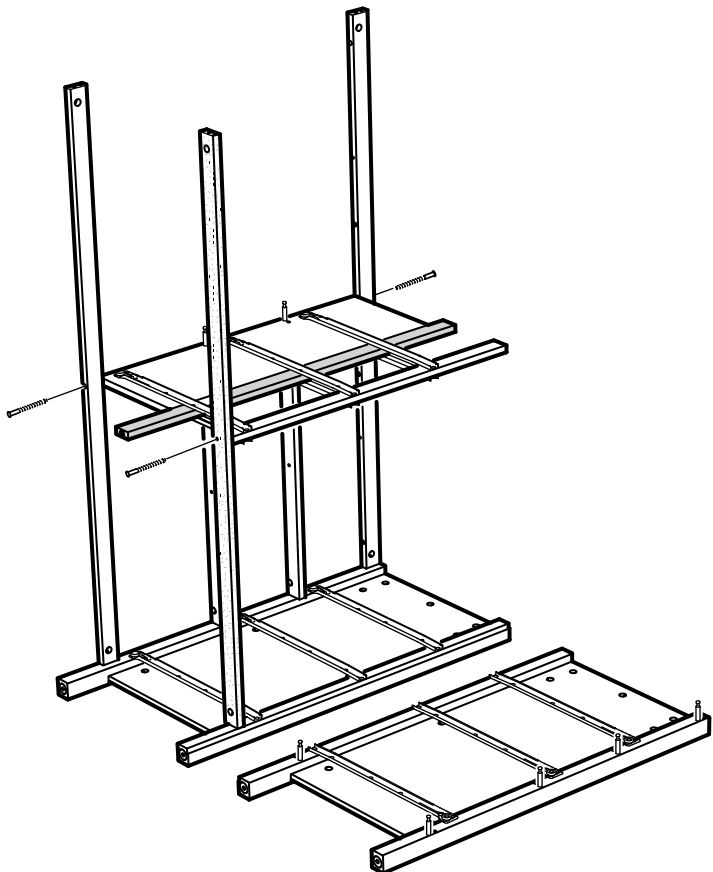
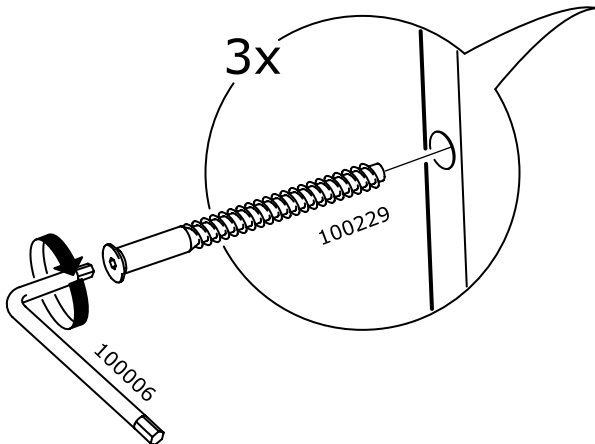
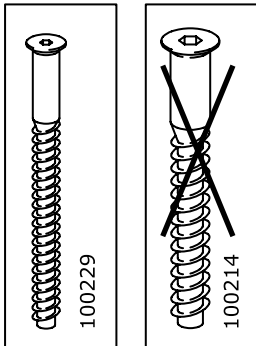

19

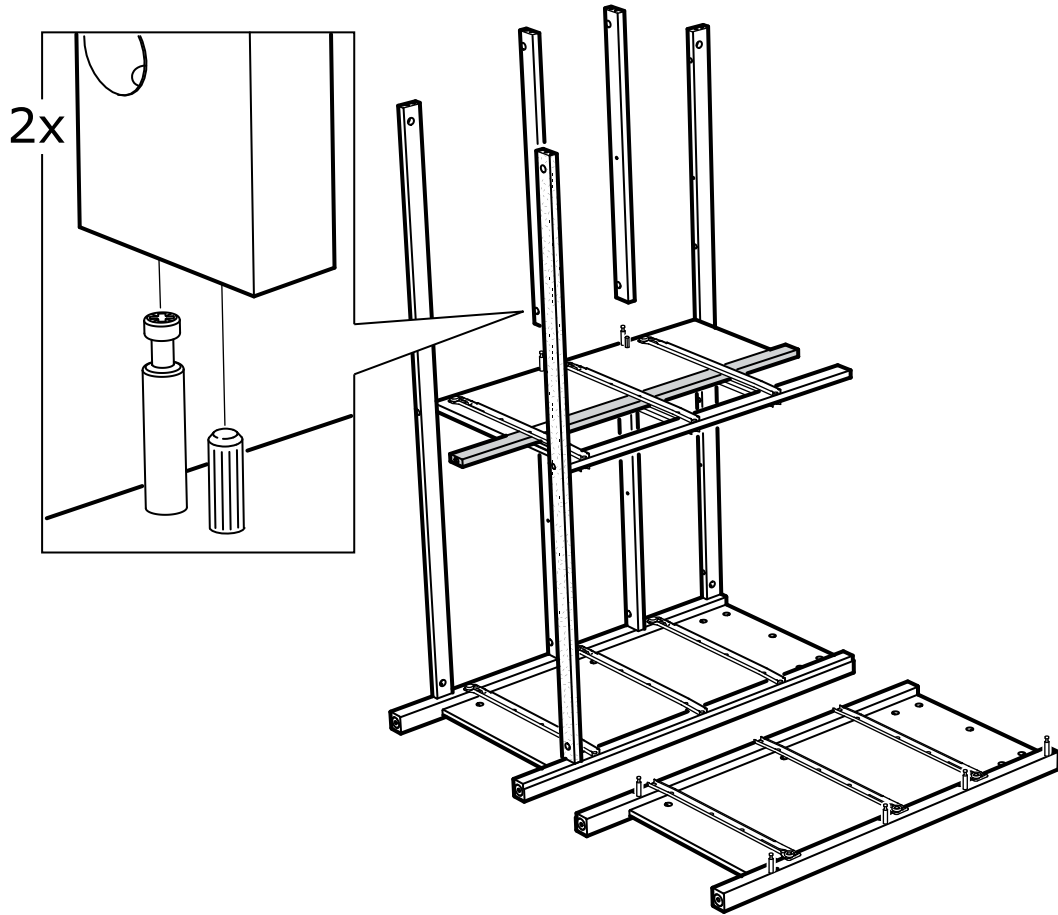

20

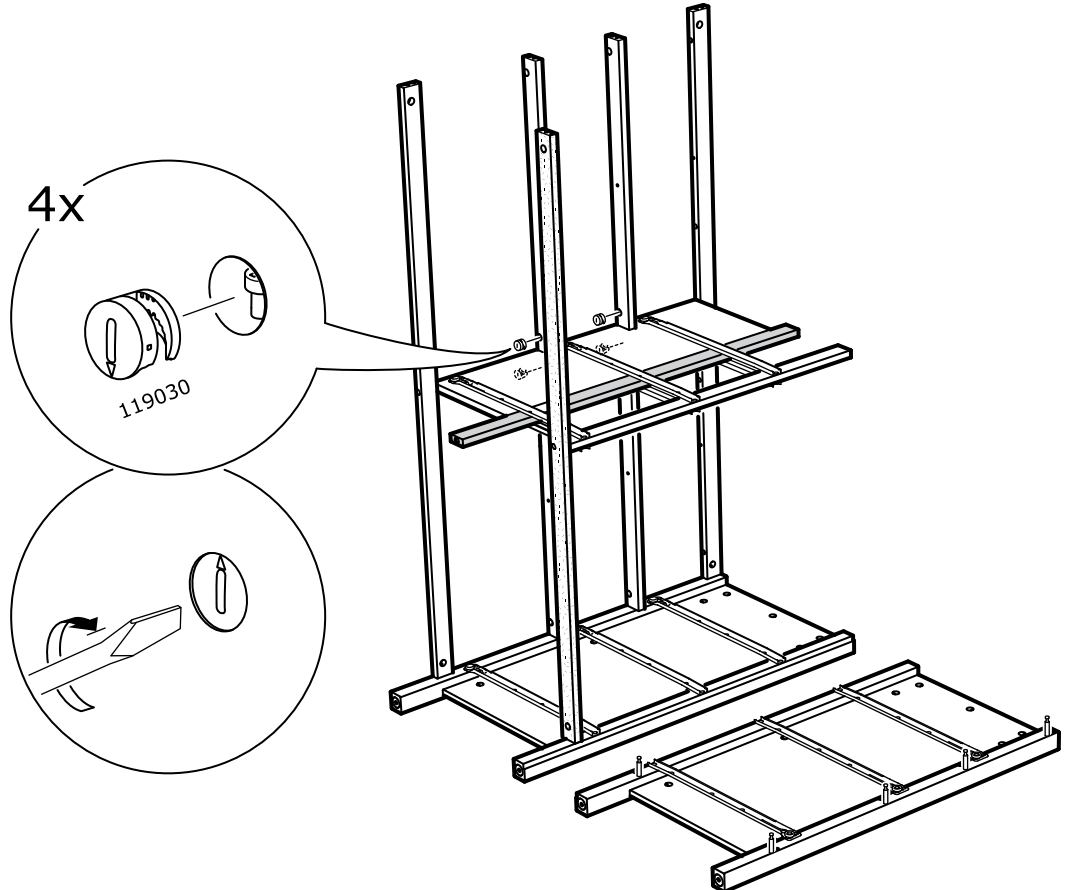

21

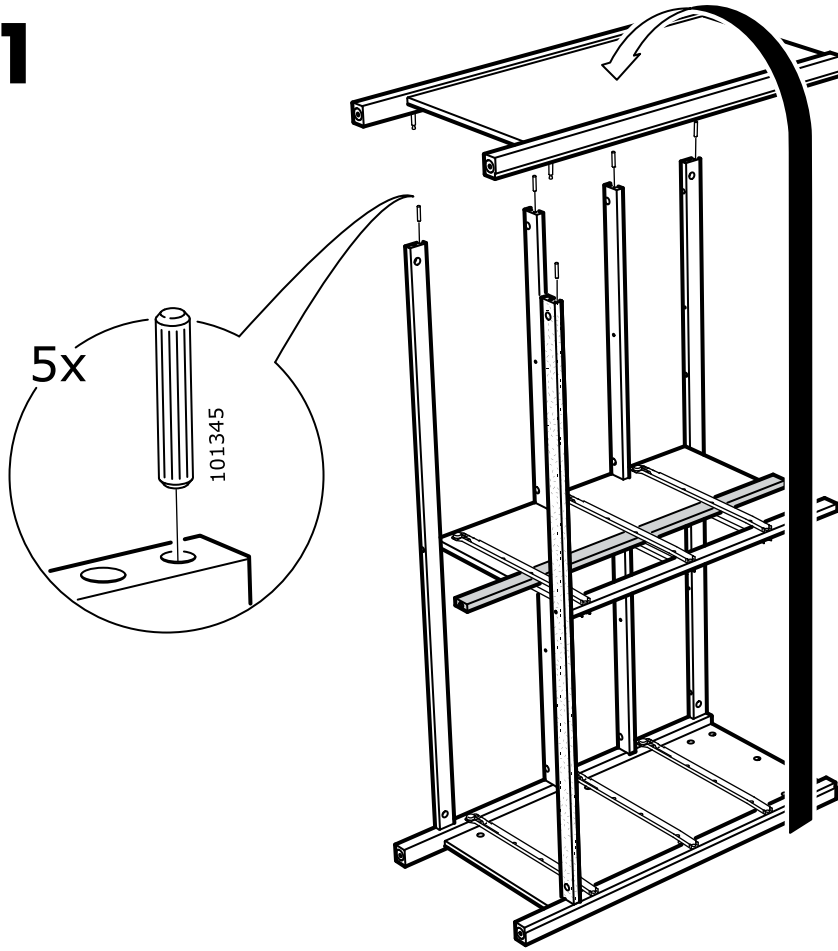

22

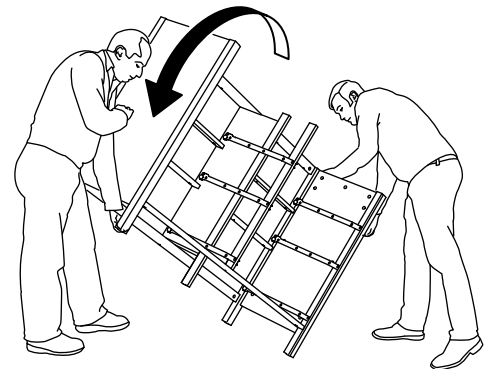
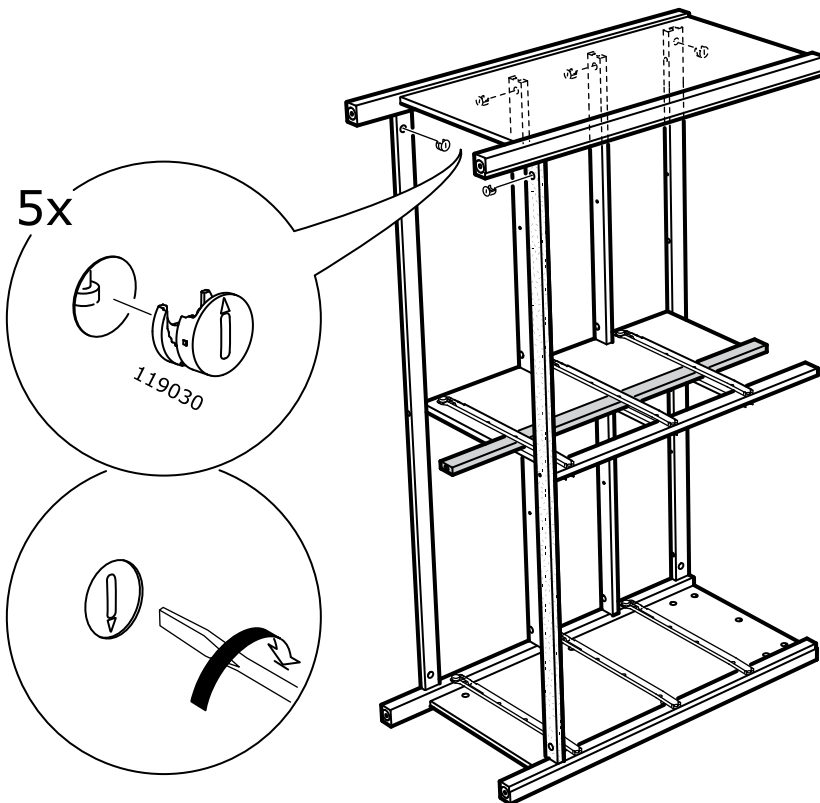

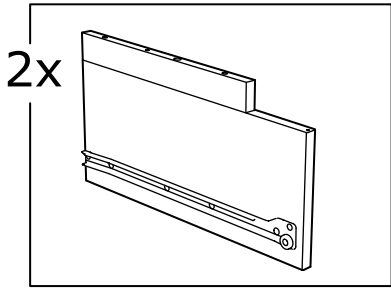

23

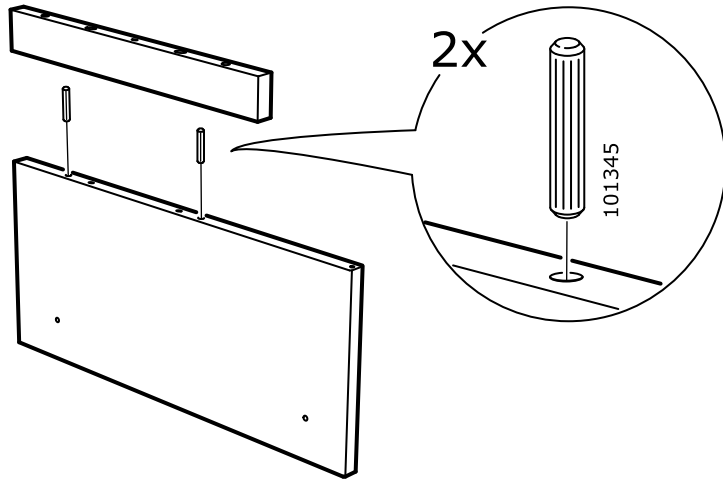

24

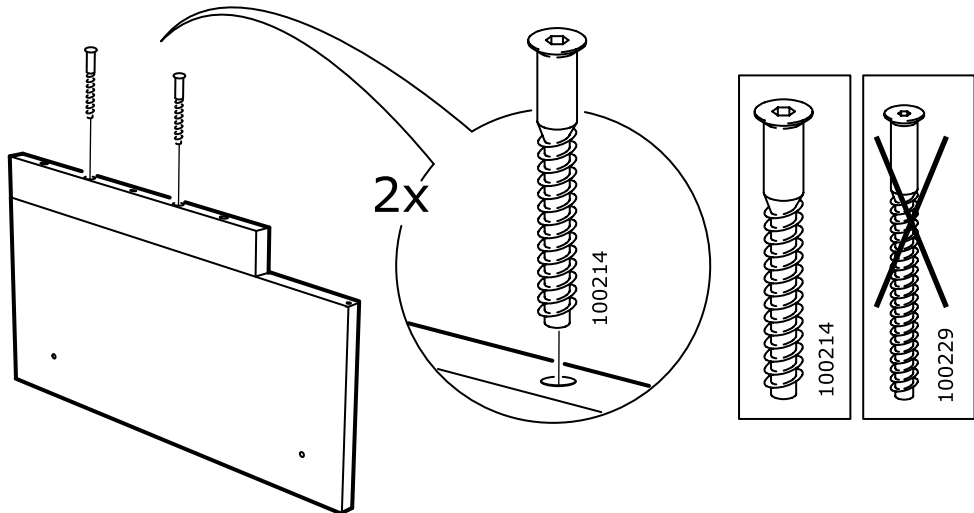

25

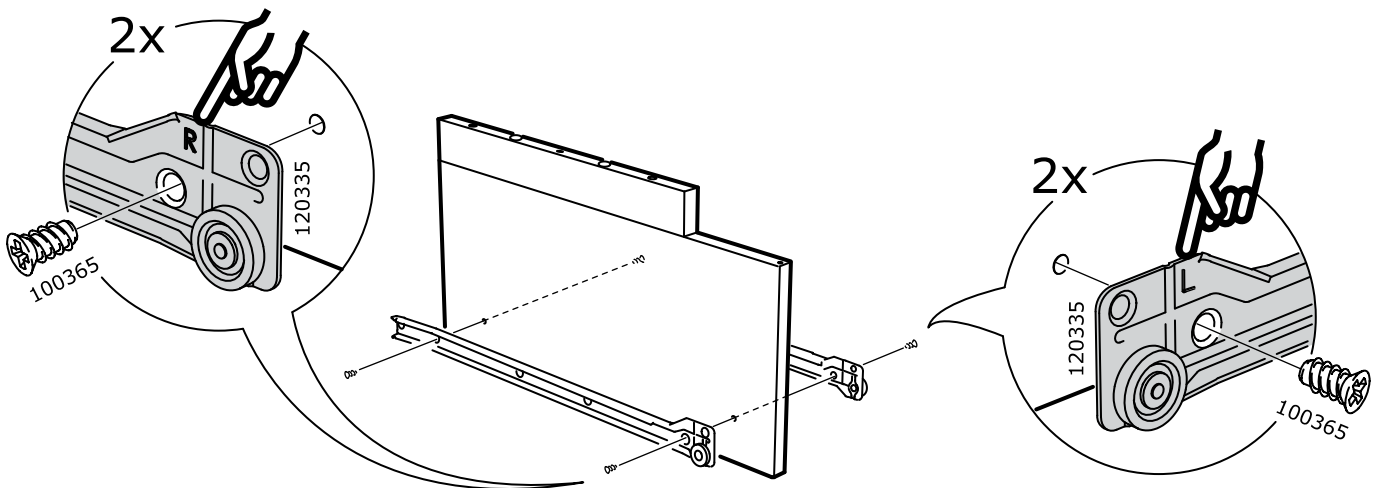

26

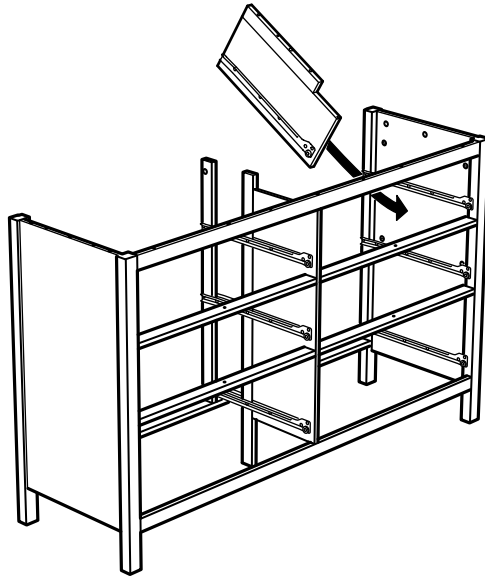

27

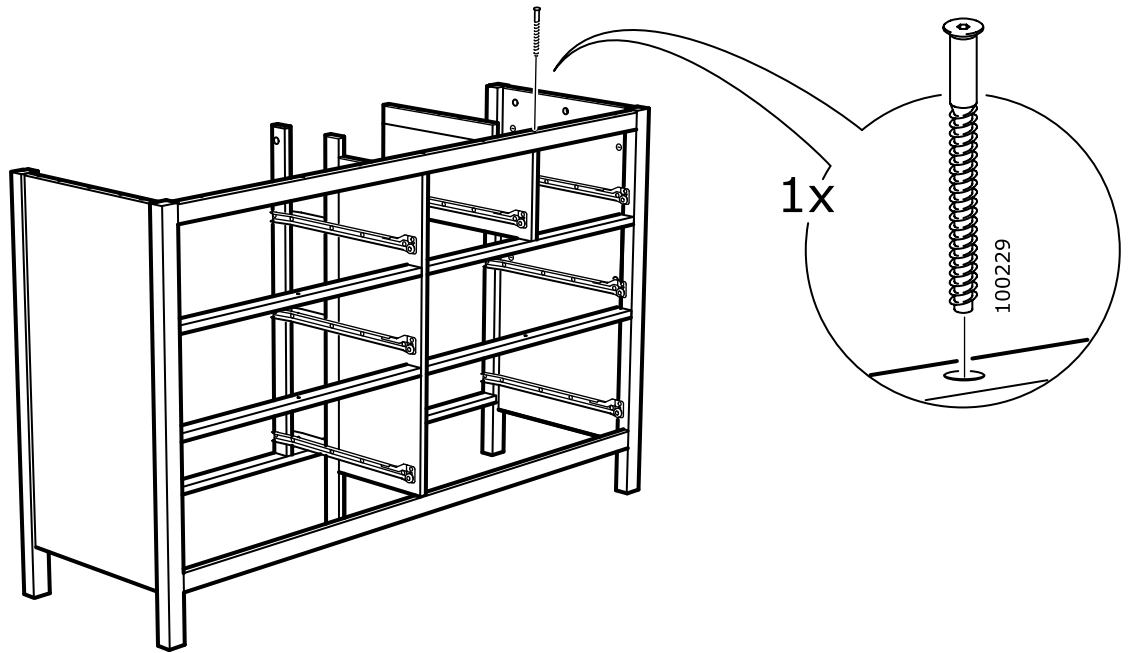

28

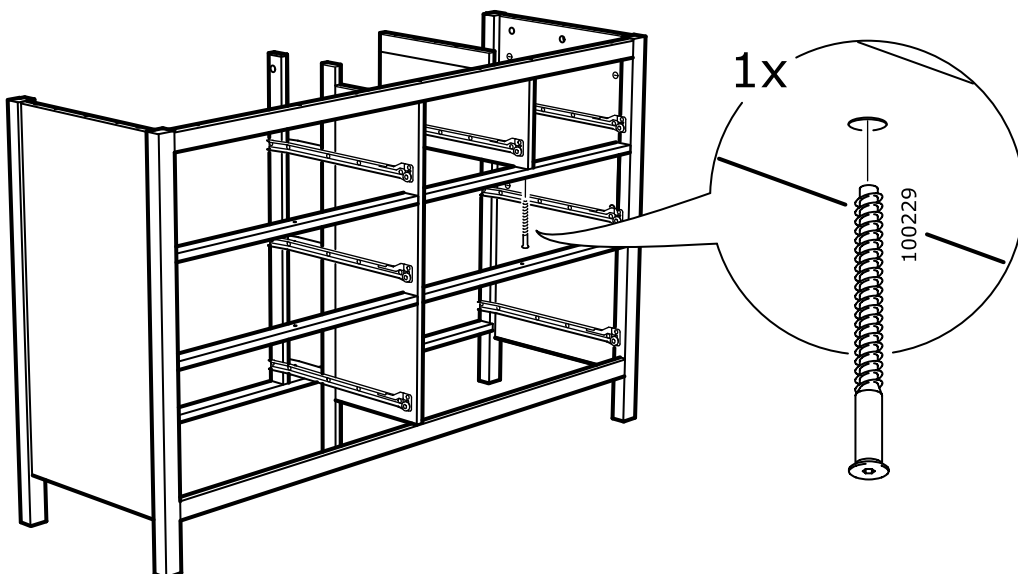

29



30

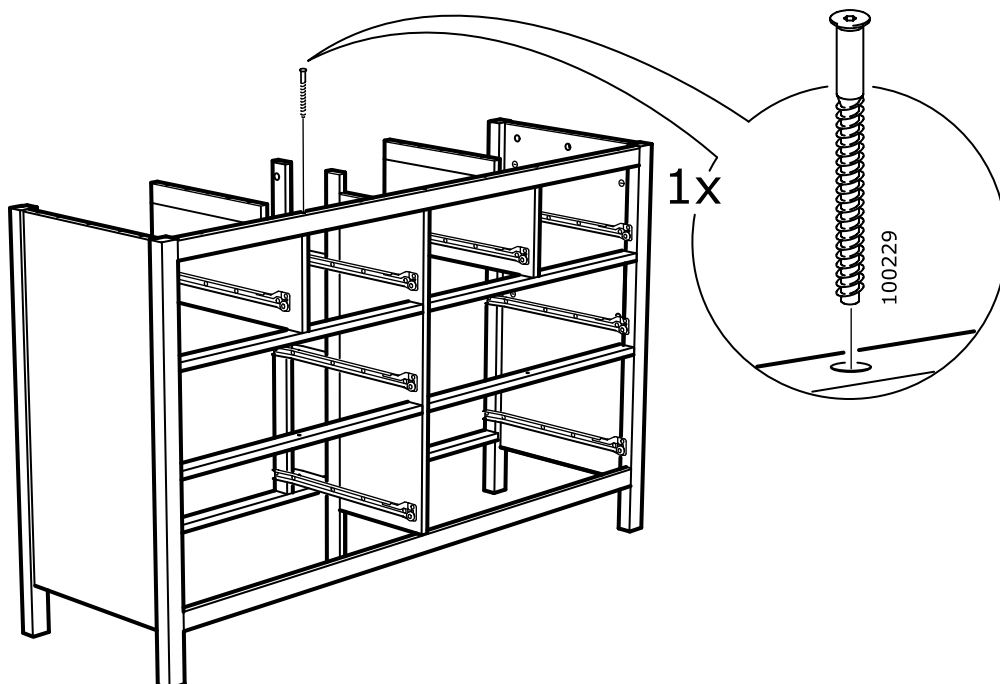

31

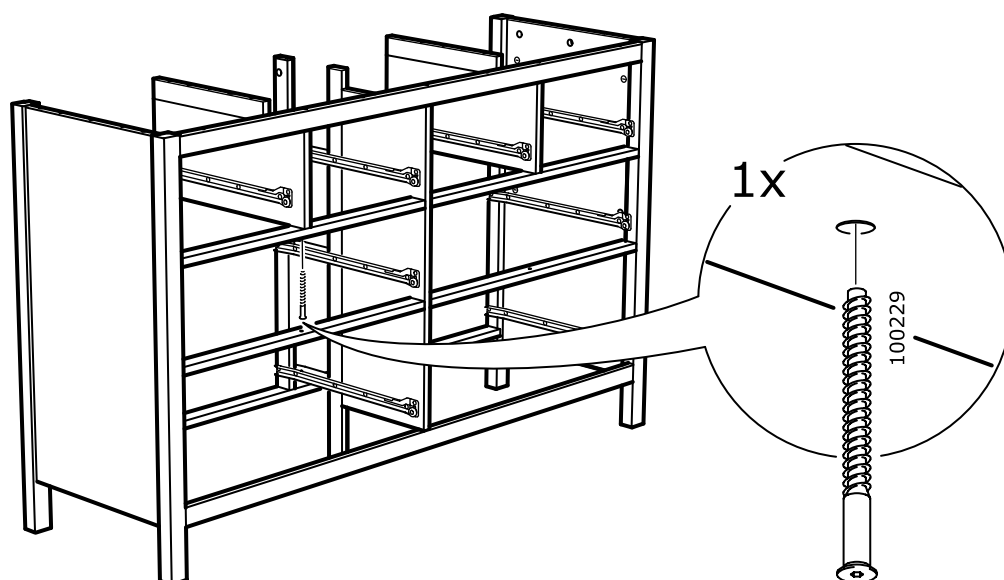

32

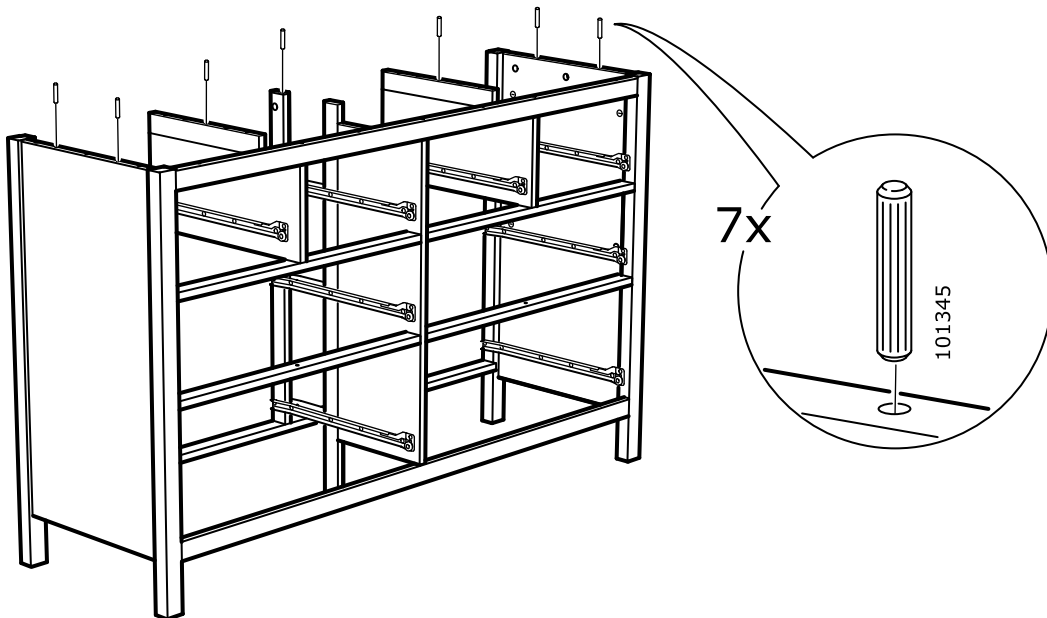

33

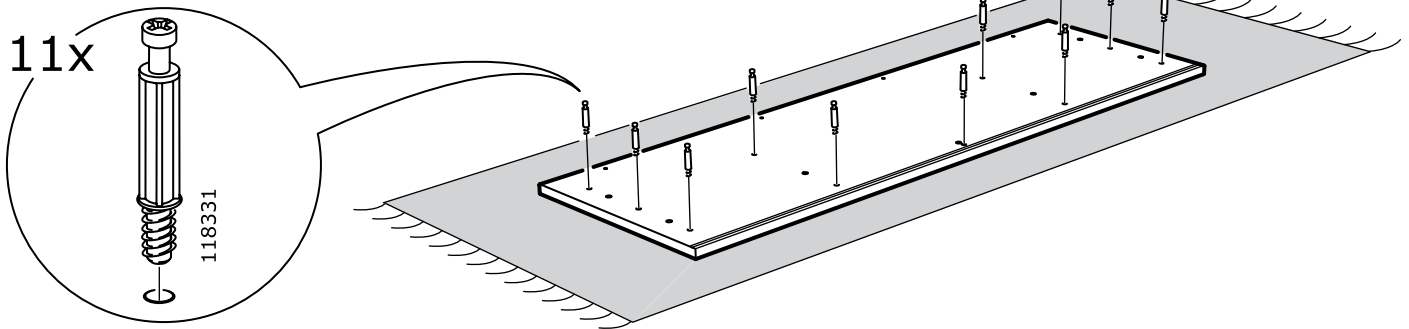

34

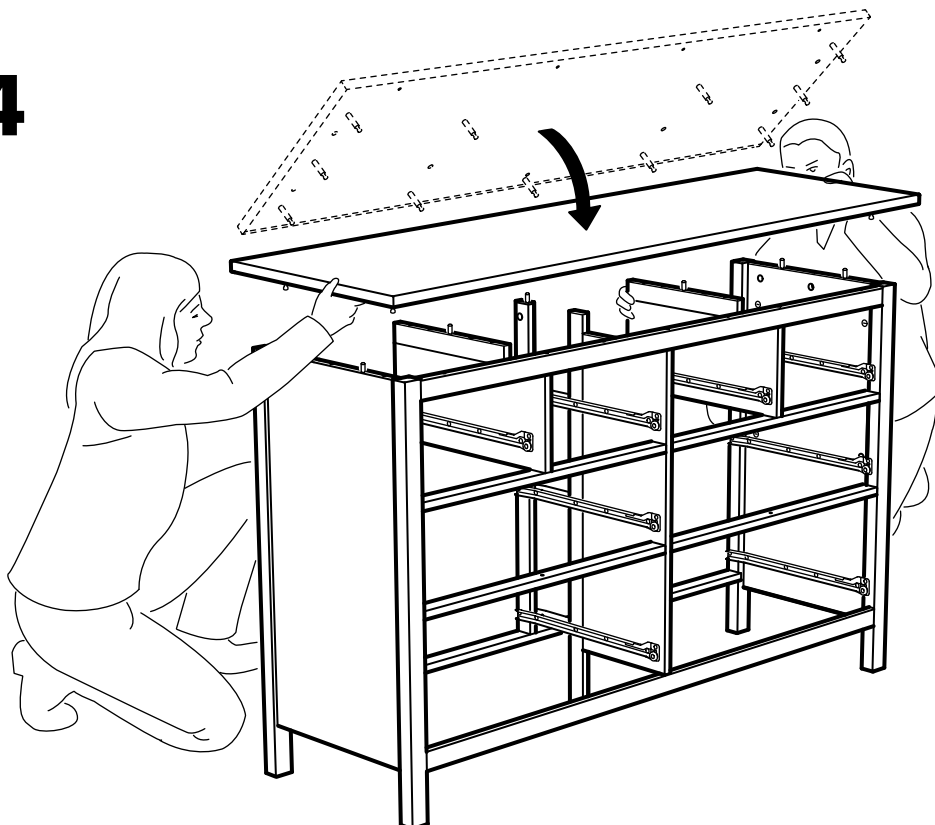

35

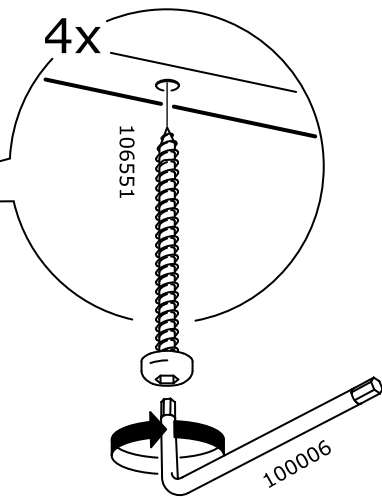
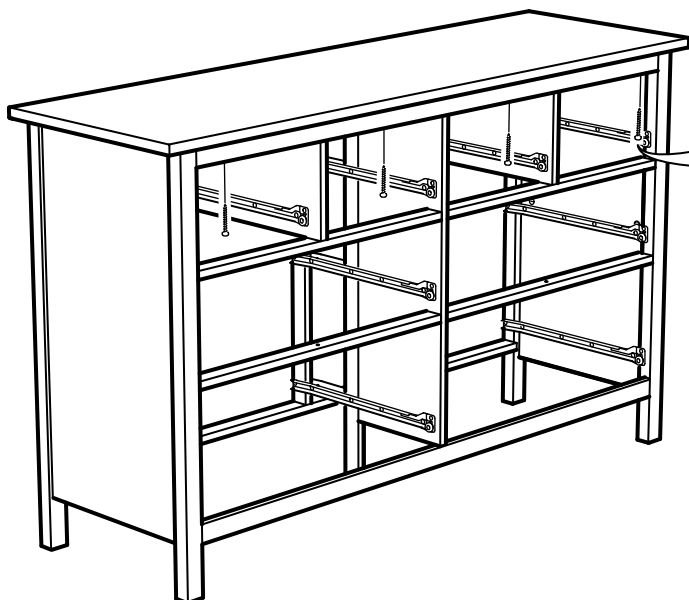

36

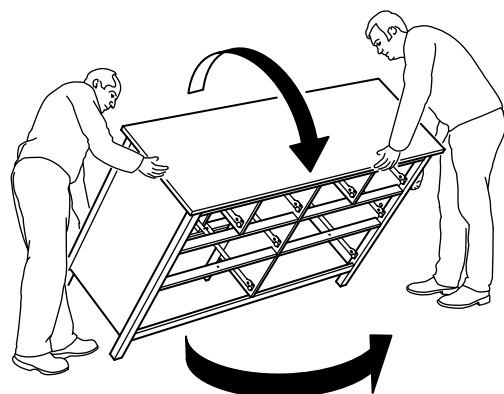
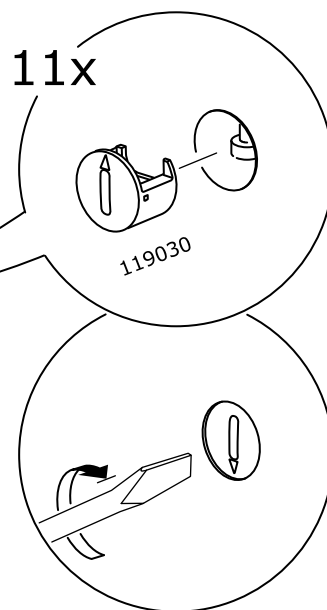
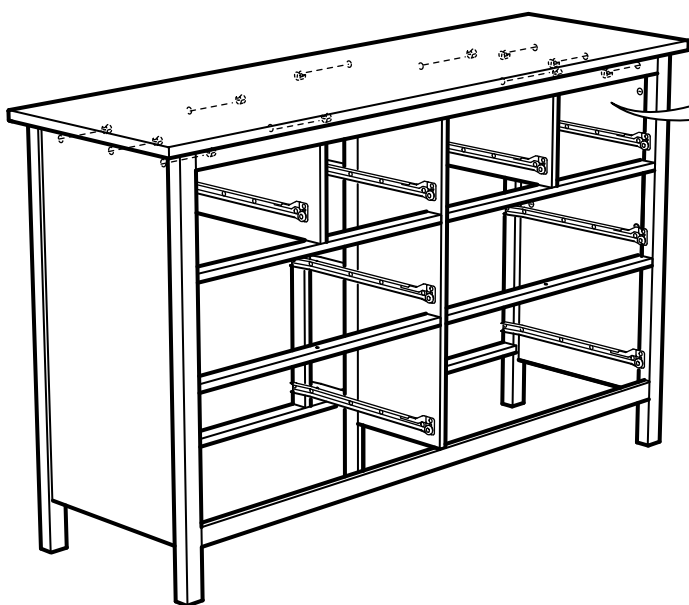

37

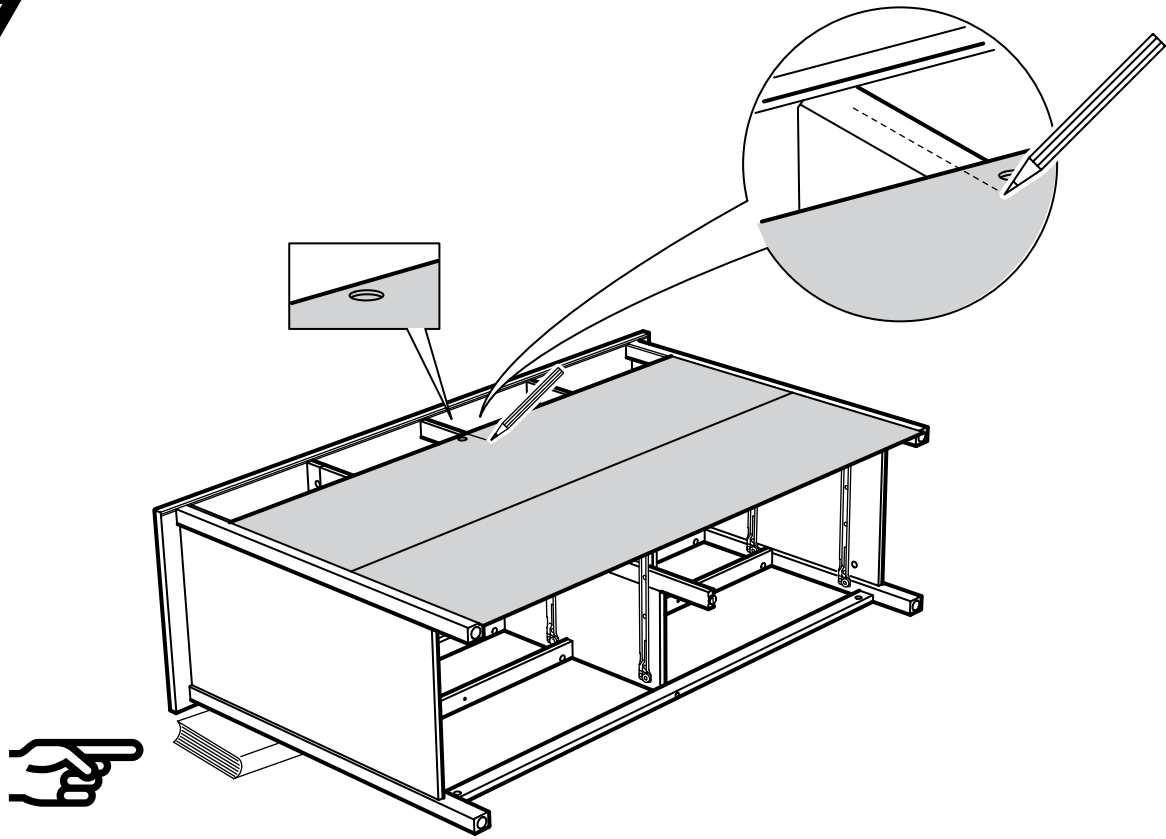

38

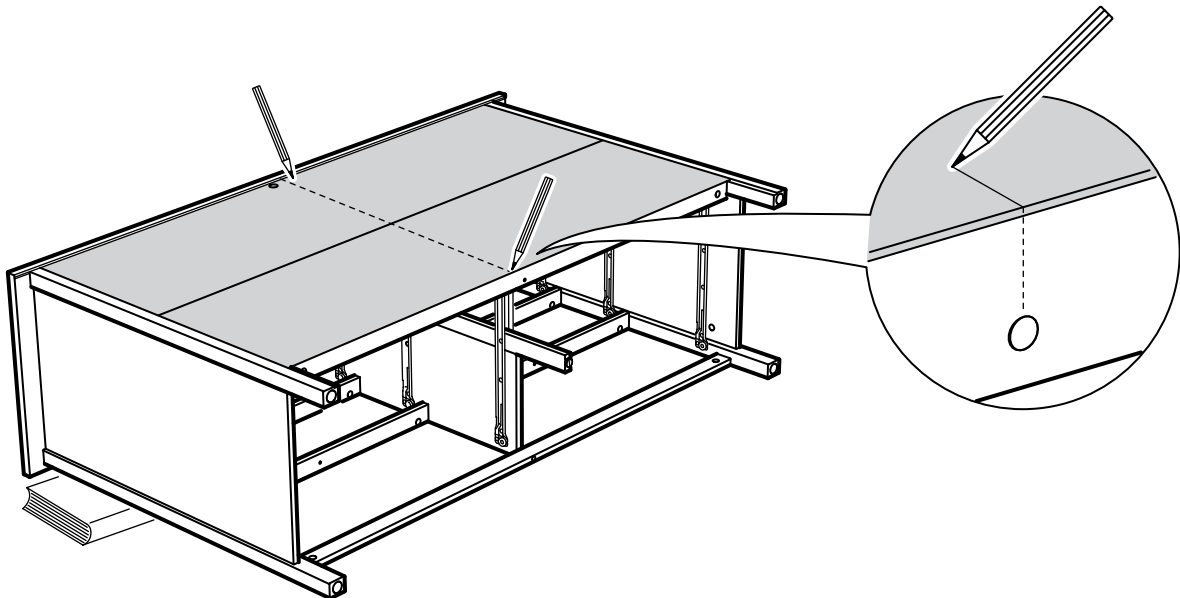

39

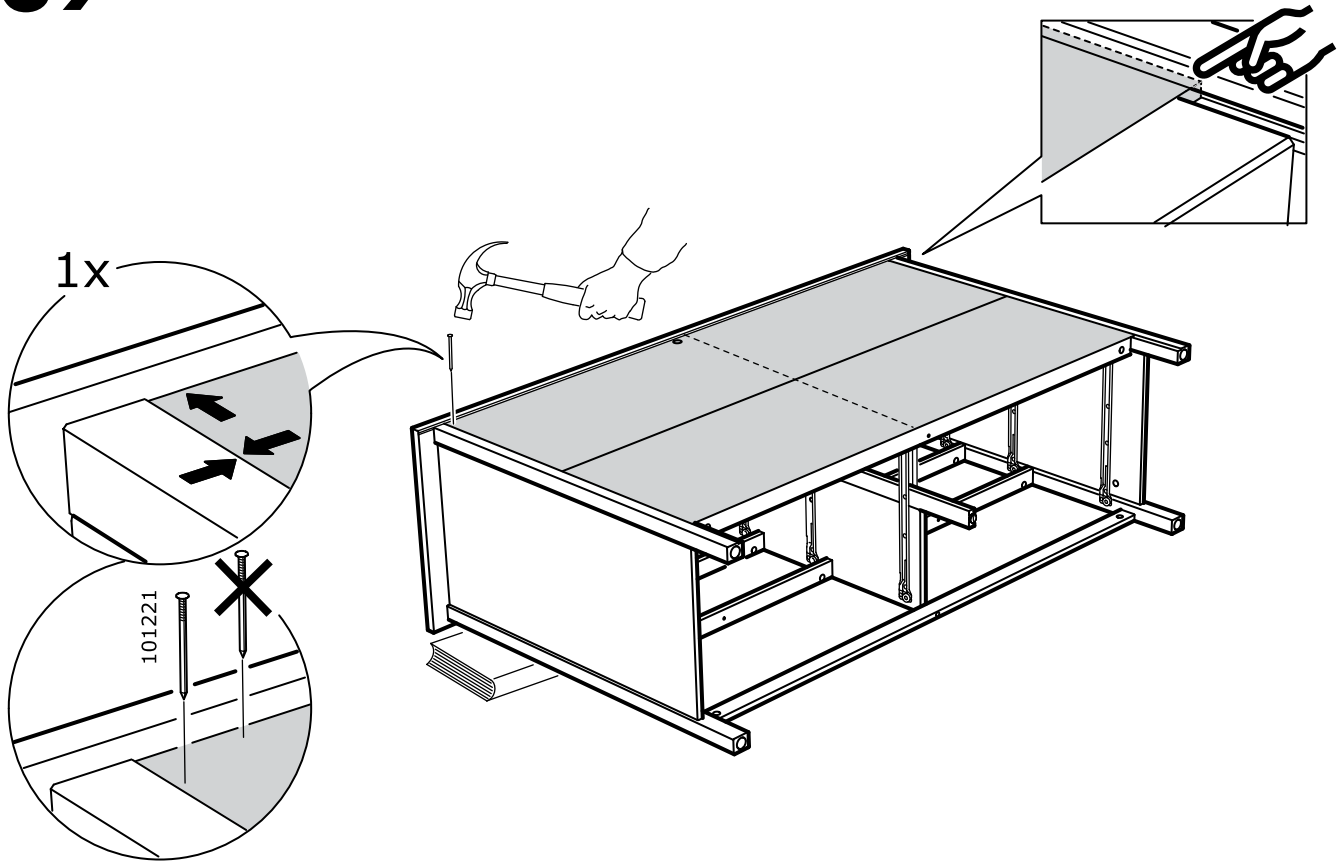

40

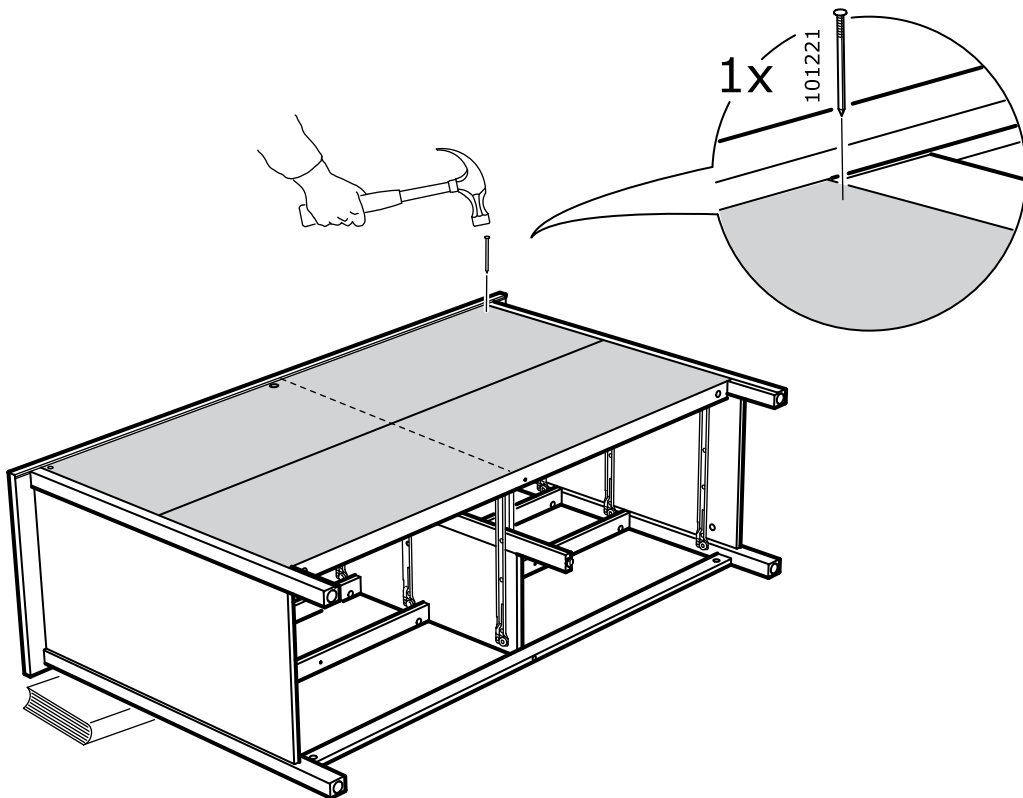

41

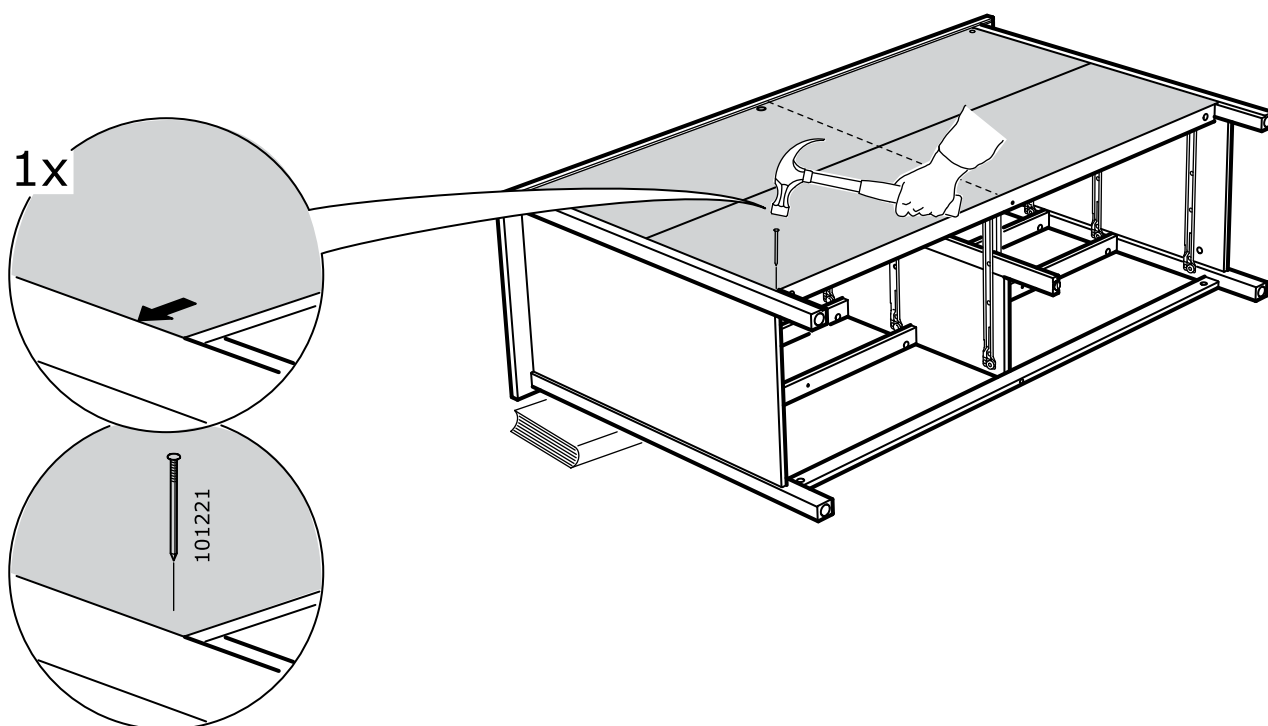

42

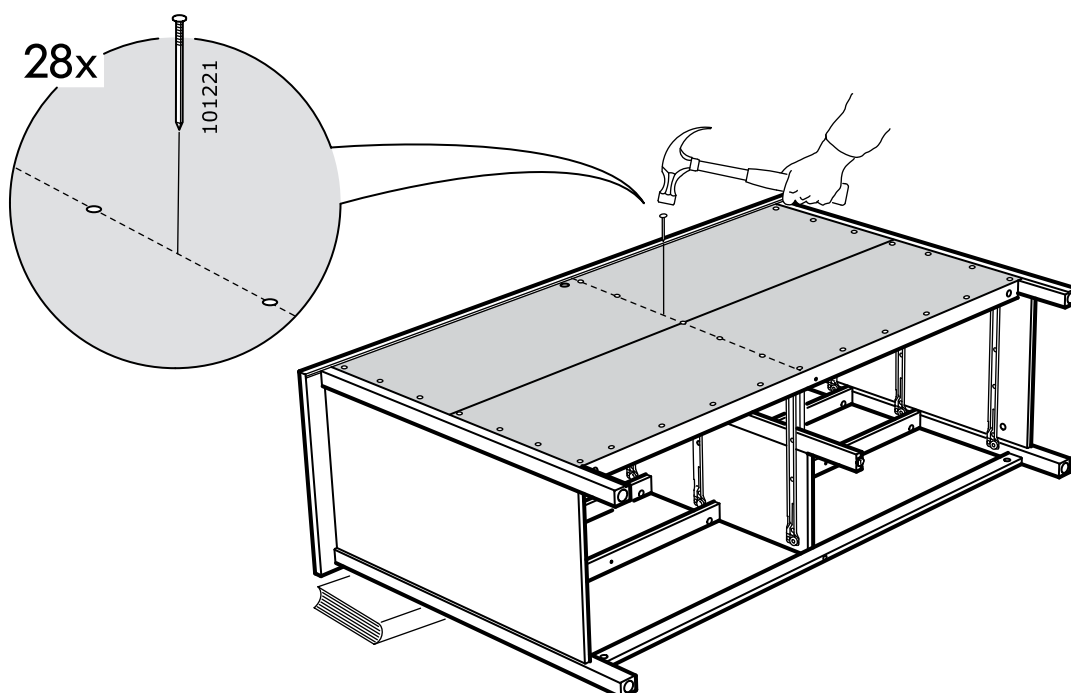

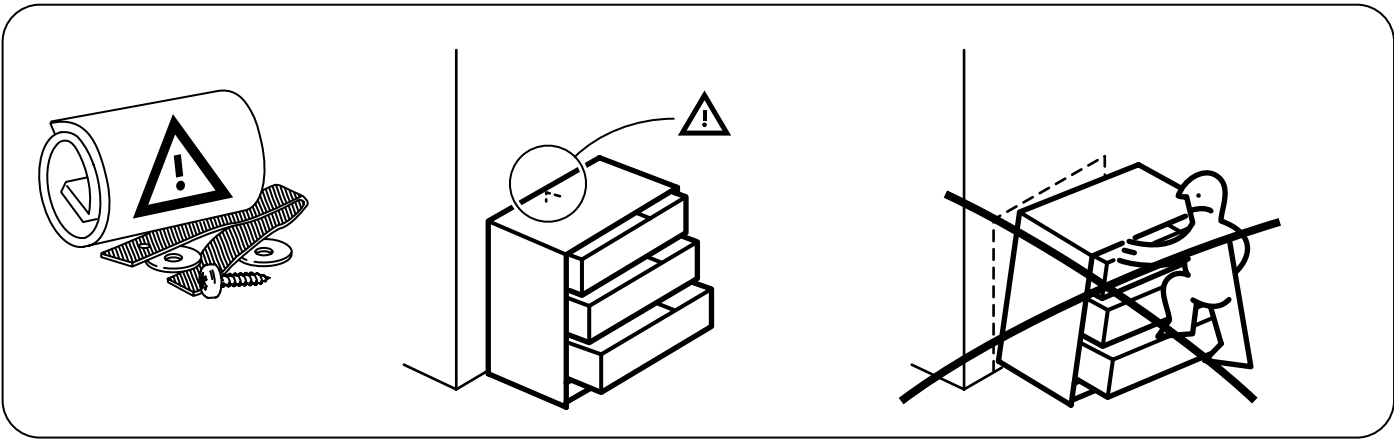

43

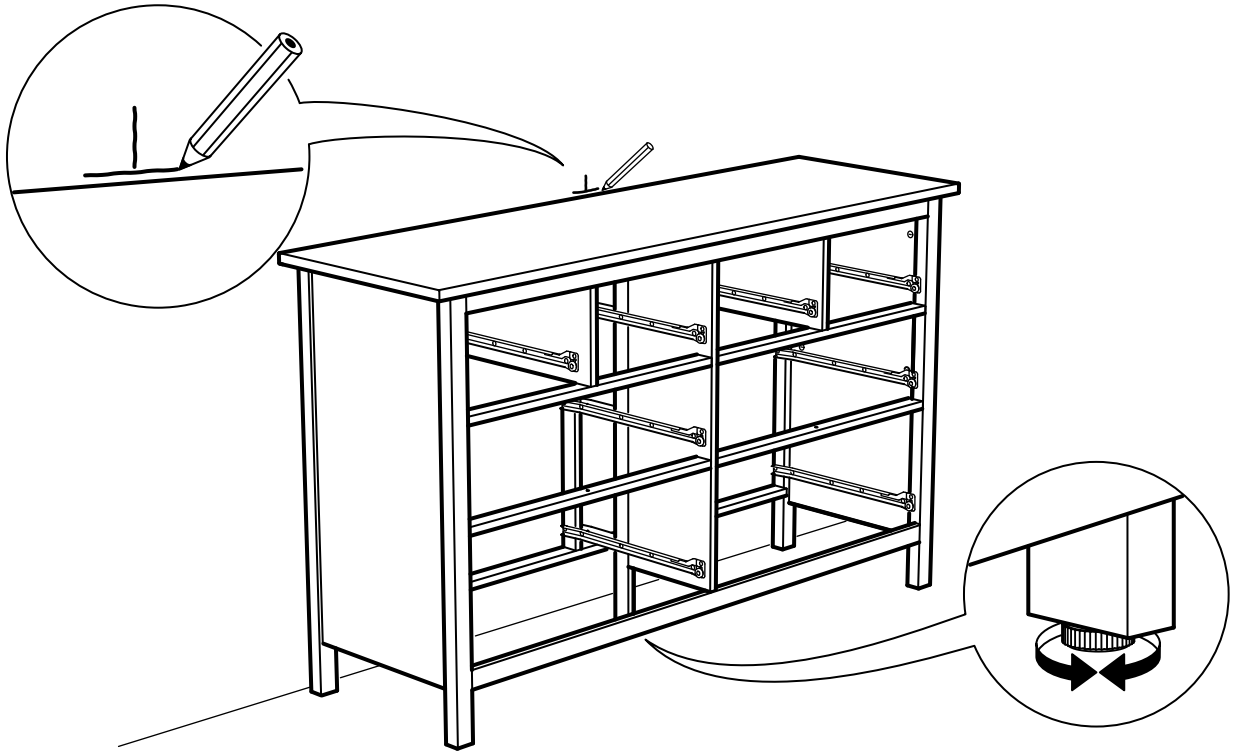

44

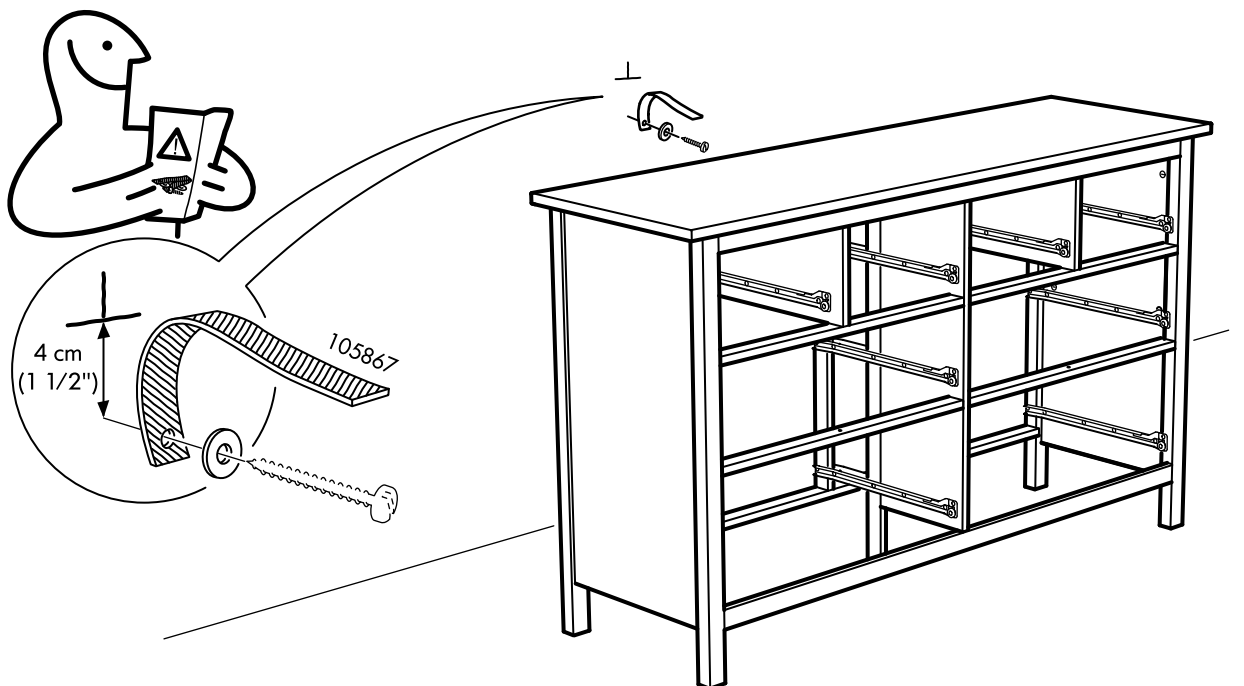

45

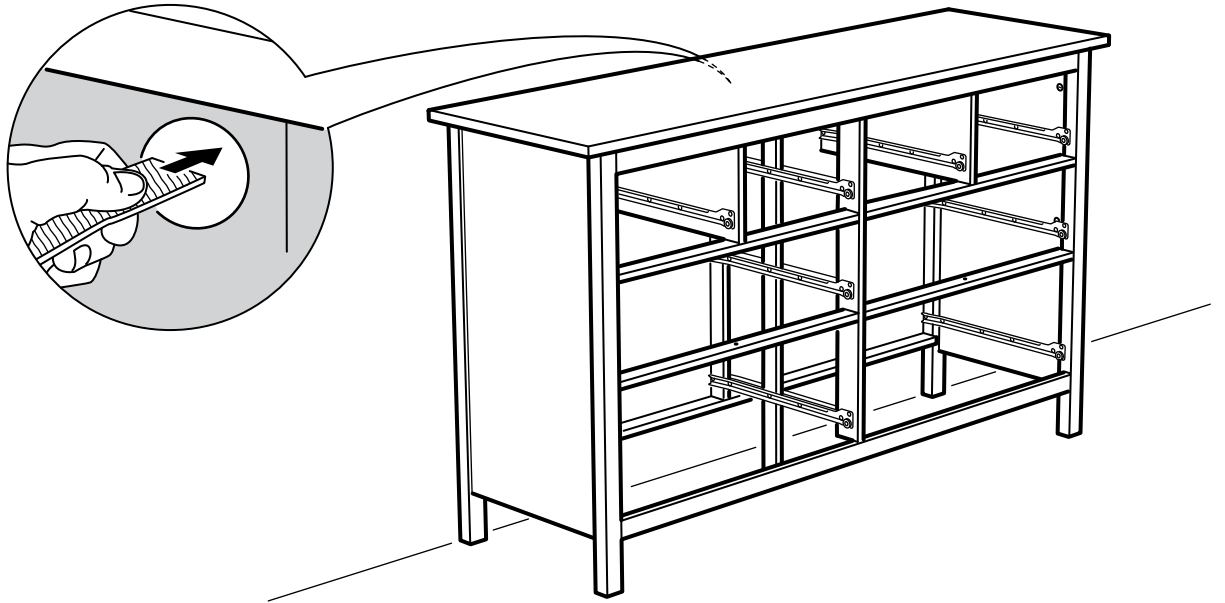

46

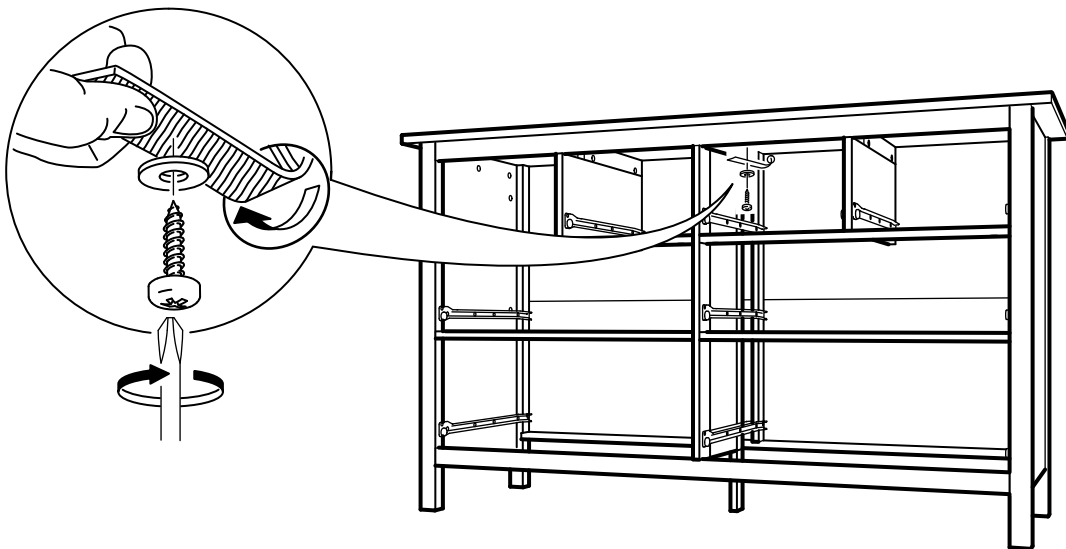

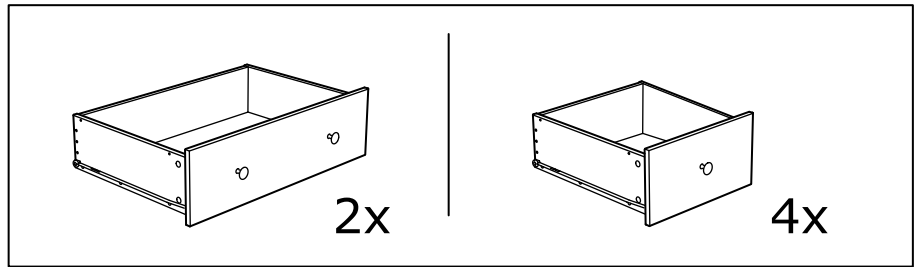
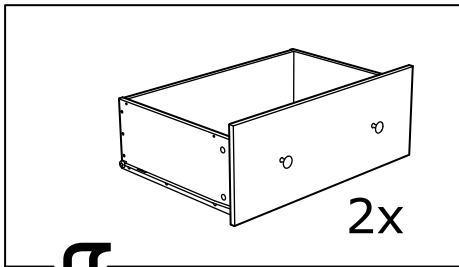

↕
47

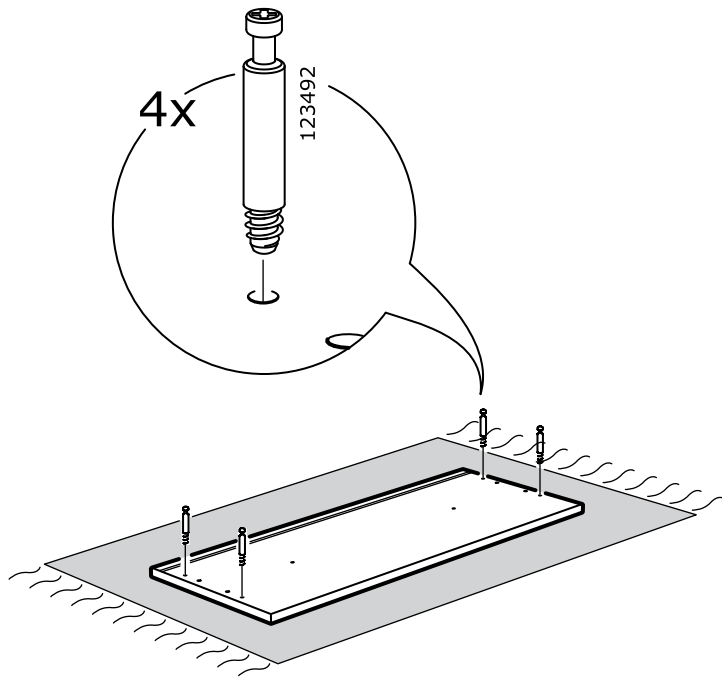
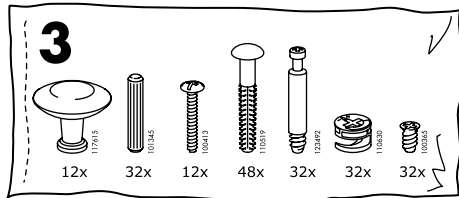

48

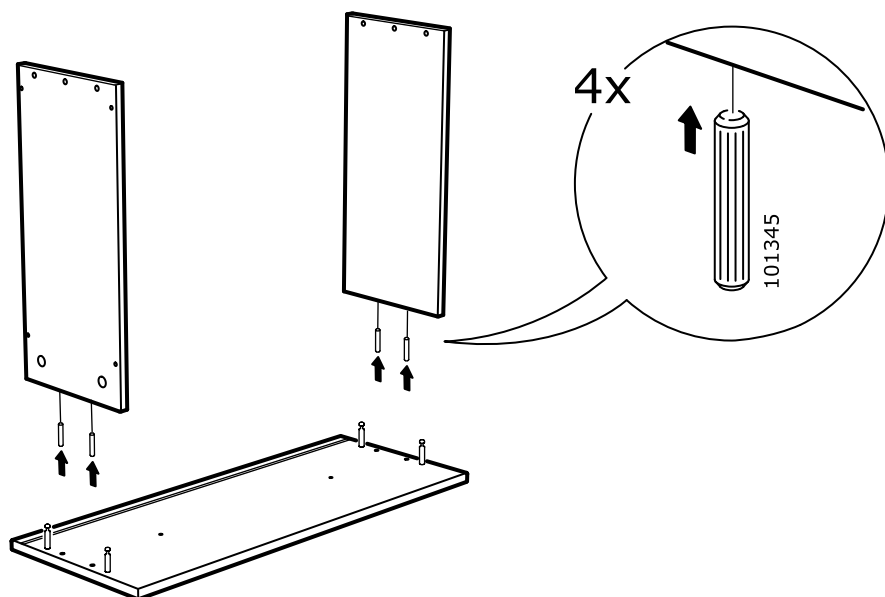

49

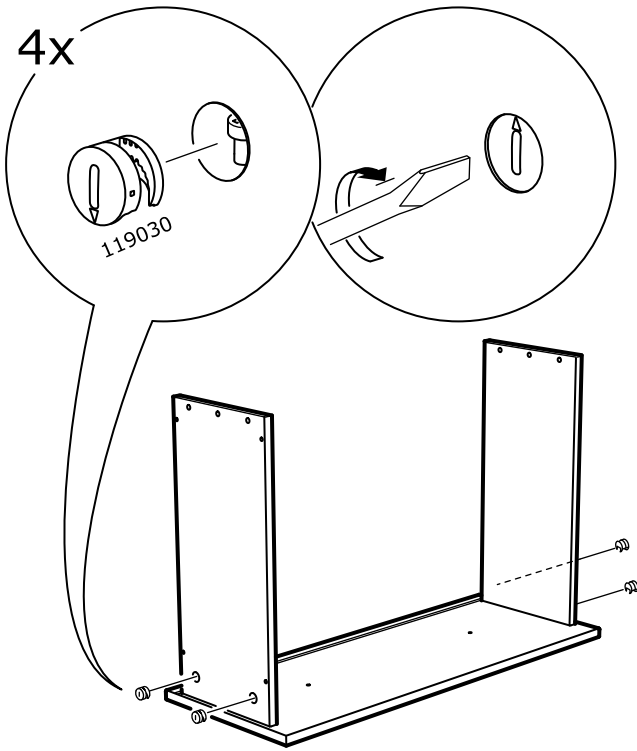

50

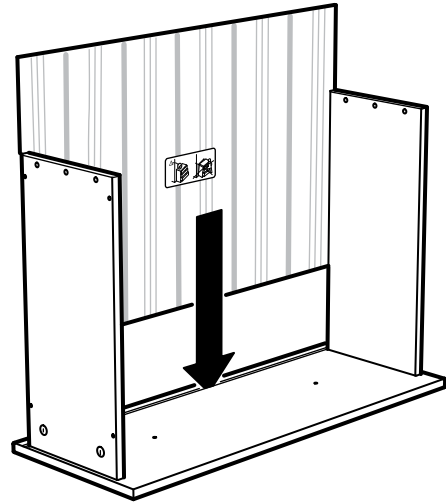

51

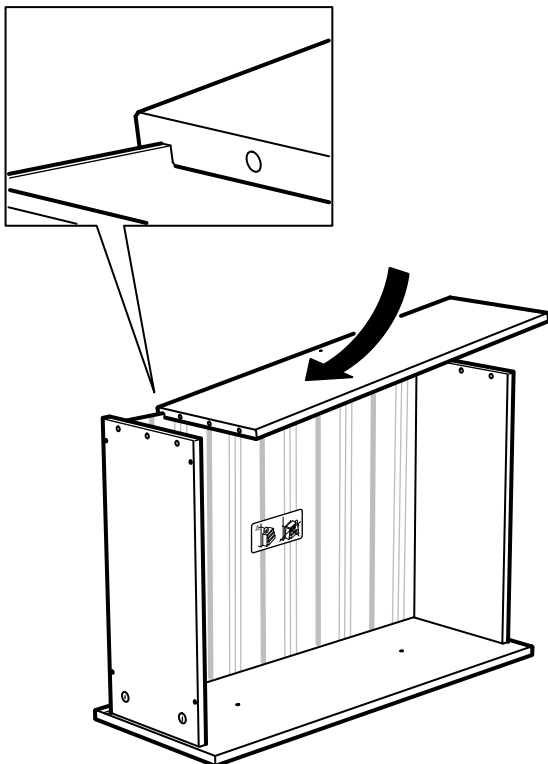

52

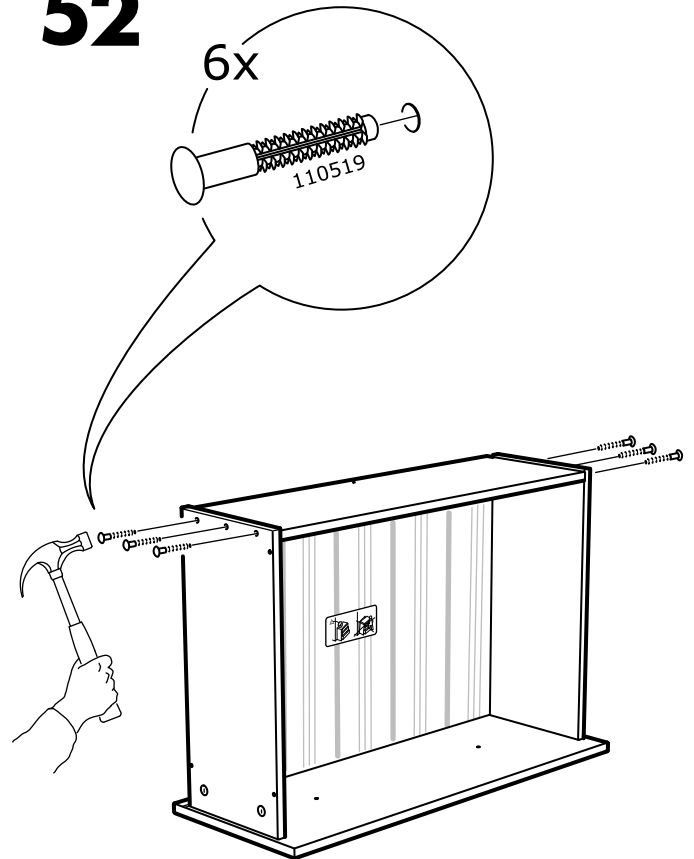

53

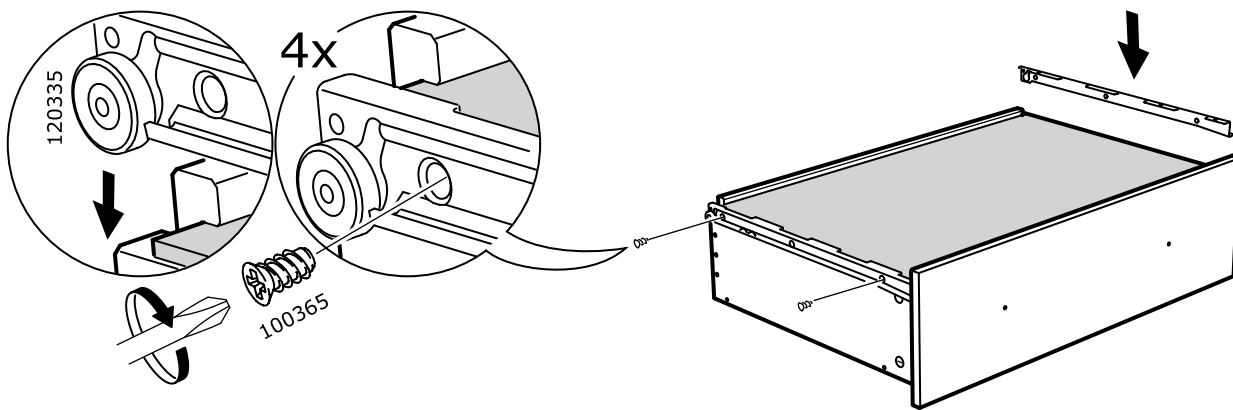

54

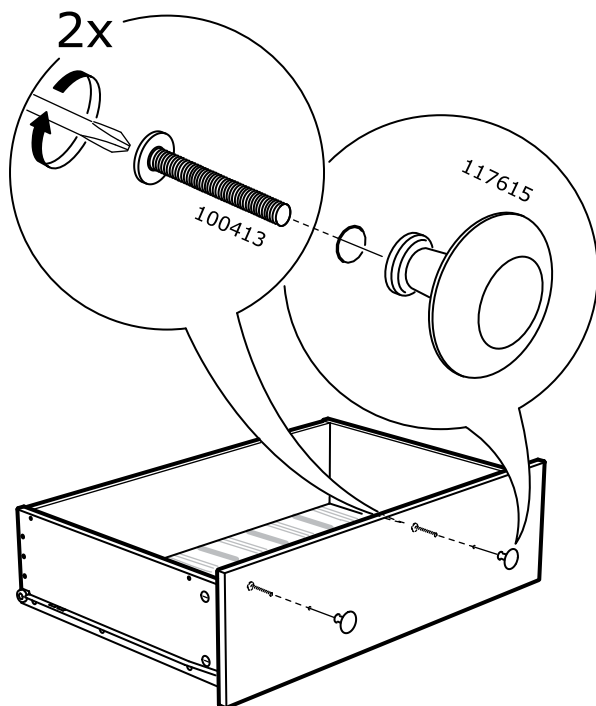

55

