

LAGAN

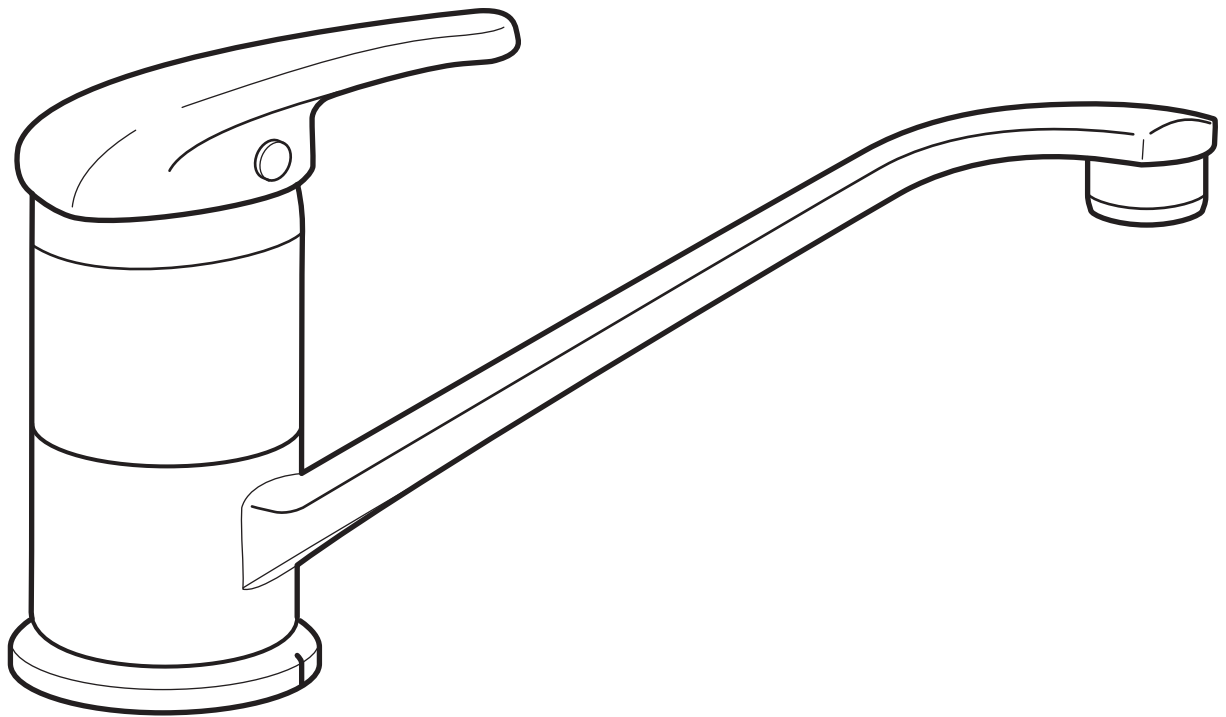

Design and Quality
IKEA of Sweden

**English**

Installation must be performed in compliance with current local construction and plumbing regulations. If in doubt, contact a professional.

Français

L'installation doit être réalisée en conformité avec les normes actuelles relatives à la construction et à la plomberie. En cas de doute, contacter un professionnel.

Español

La instalación debe realizarse siguiendo las normativas actuales sobre construcción y fontanería. En caso de duda, ponte en contacto con un profesional.

**English**

Switch off main shut-off valve before changing mixer tap.

Français

Fermer le robinet central d'eau avant de changer le mitigeur.

Español

Cierra la llave de paso general antes de cambiar el grifo.



2x

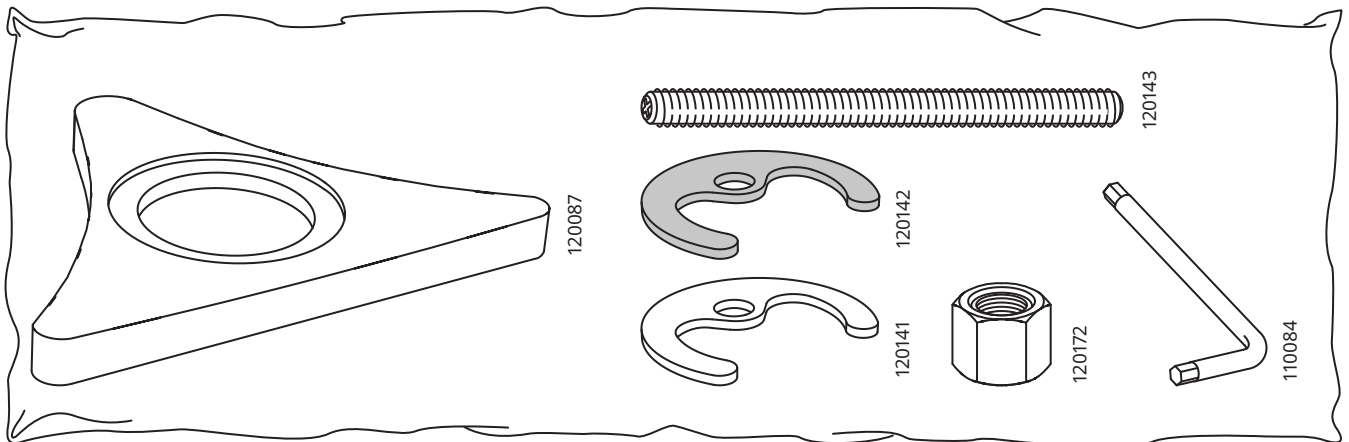
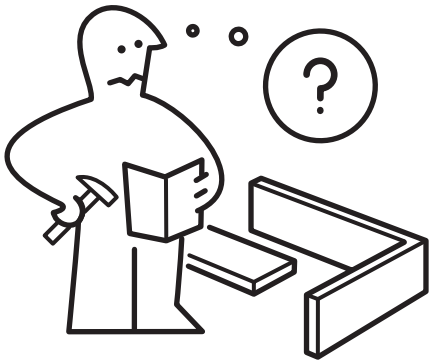

1

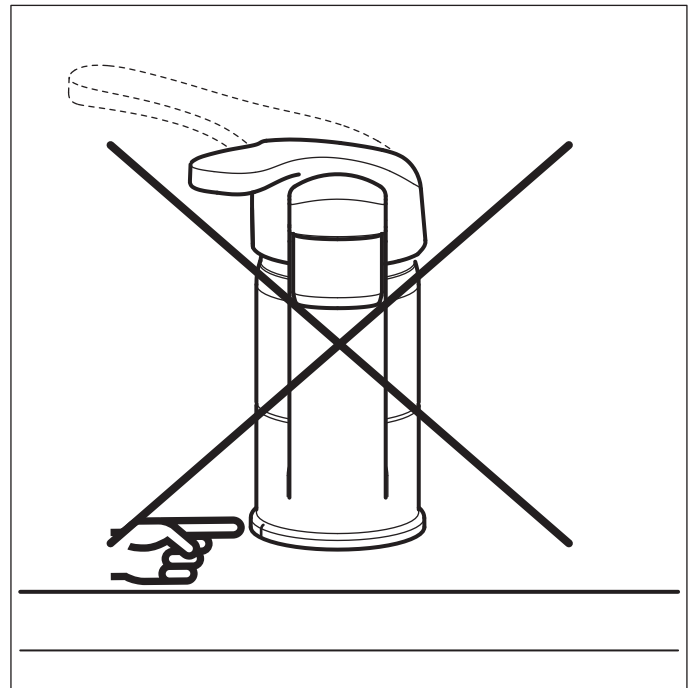
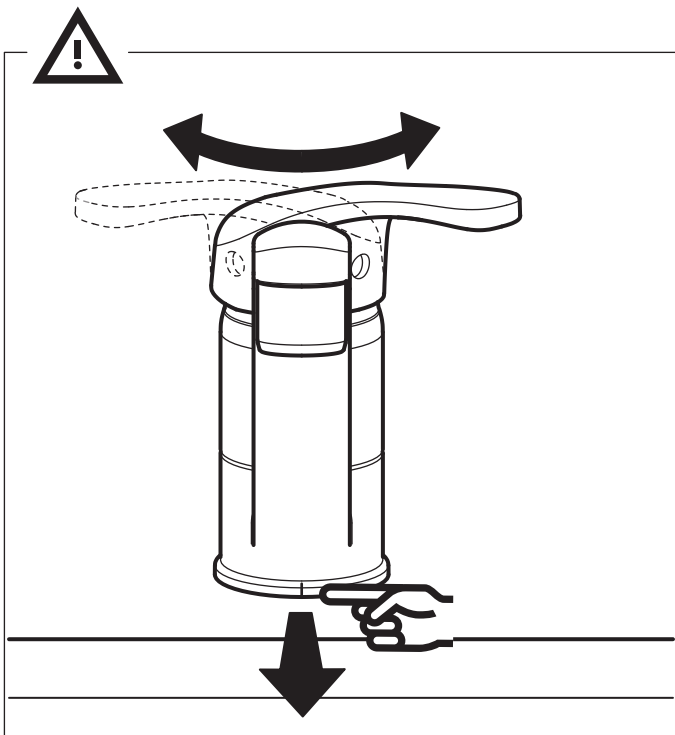
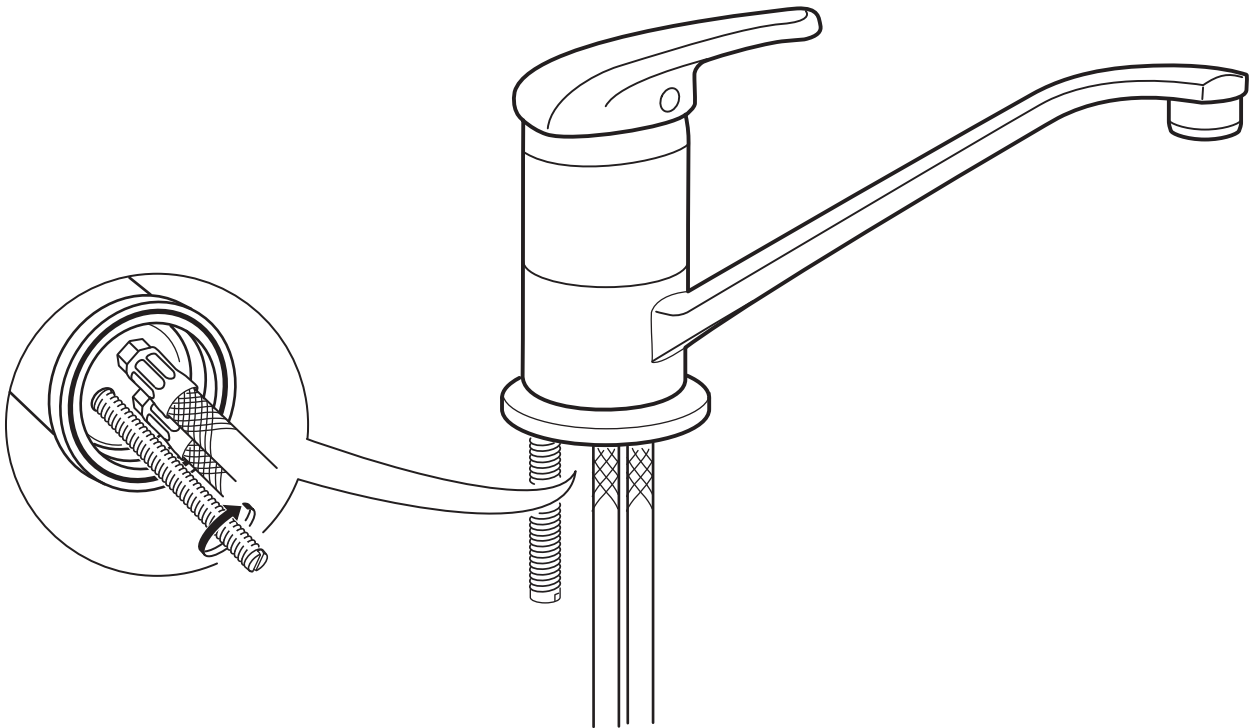

English
Seal the open surfaces with silicone to prevent water from penetrating the worktop upon any leaks. Silicone is not included.

Français
Appliquer un joint de silicone sur les interstices pour éviter les infiltrations d'eau dans le plan de travail en cas de fuite. Le silicone n'est pas inclus.

Español
Aplicar silicona en las juntas para evitar que penetren líquidos en la encimera en caso de fuga. La silicona no está incluida.

2

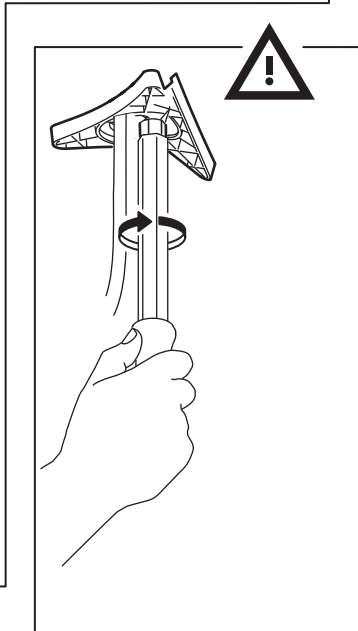
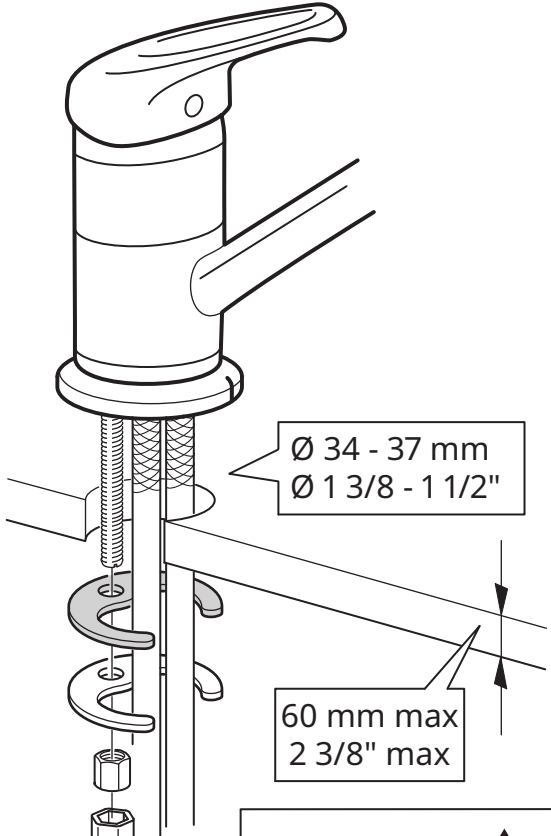
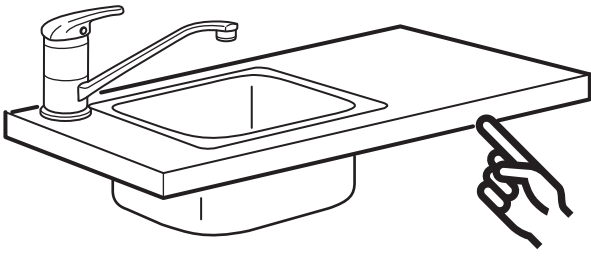

2

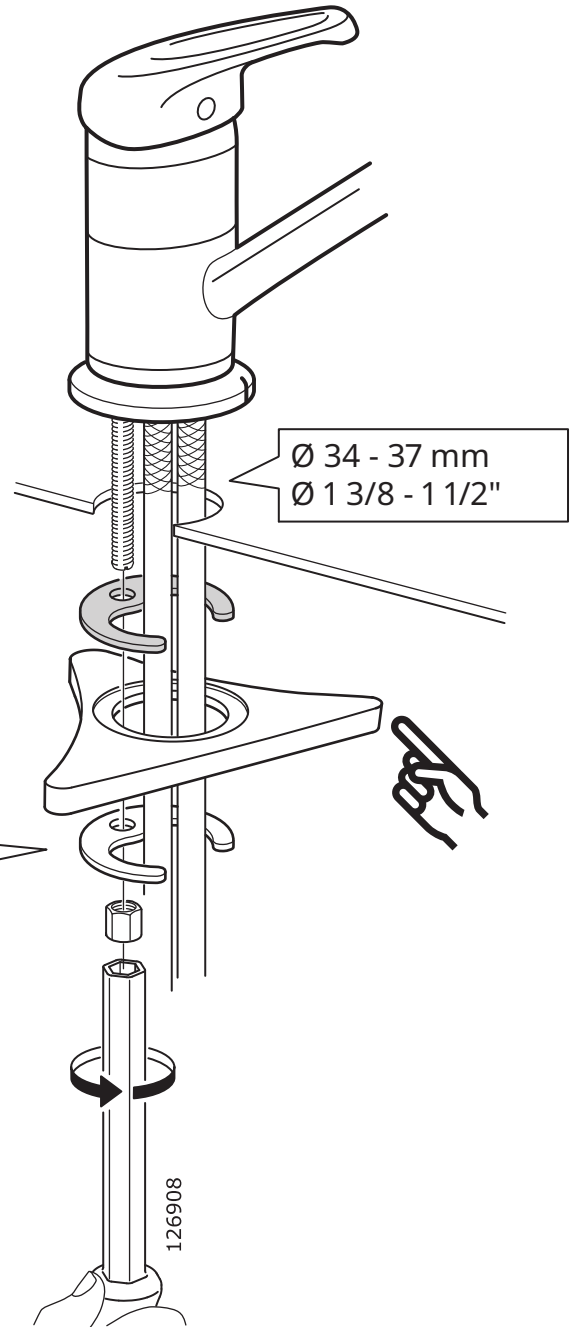
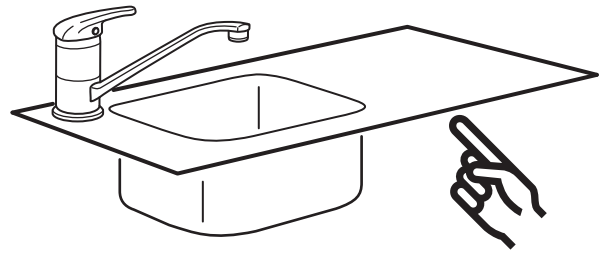

3

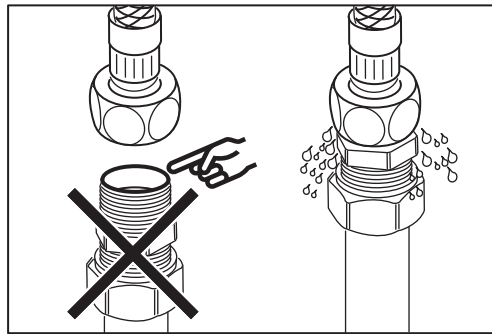
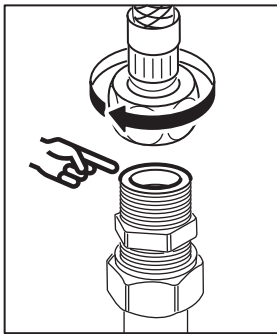
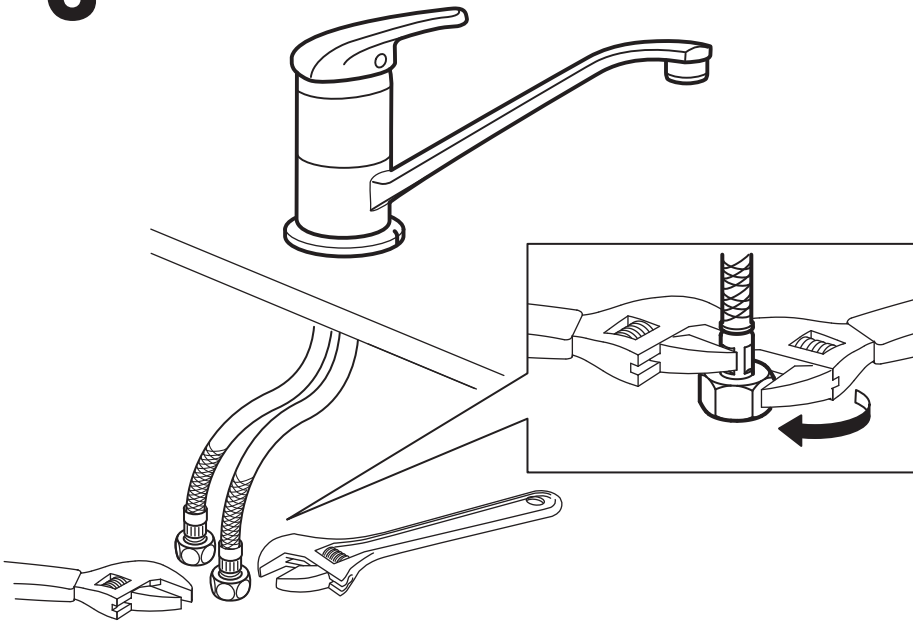

English
IMPORTANT! Do not
tighten too hard: this
can damage hoses/
pipes and washers.

Français
ATTENTION ! Ne pas serrer
trop fort : cela pourrait
abîmer les flexibles/
tuyaux et les joints.

Español
¡ATENCIÓN! No aprietes
demasiado, ya que
se pueden dañar las
tuberías/conductos y las
juntas.

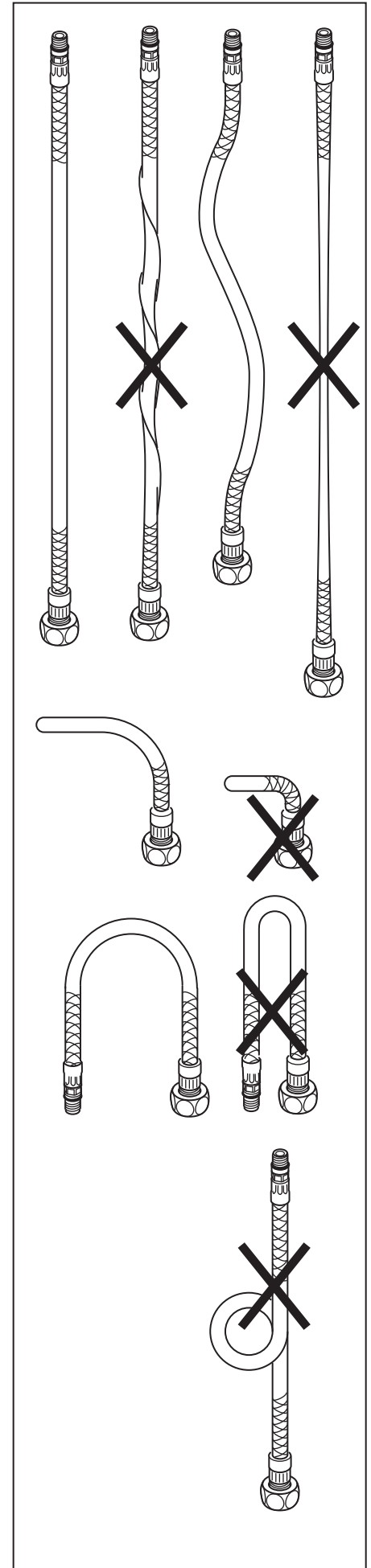

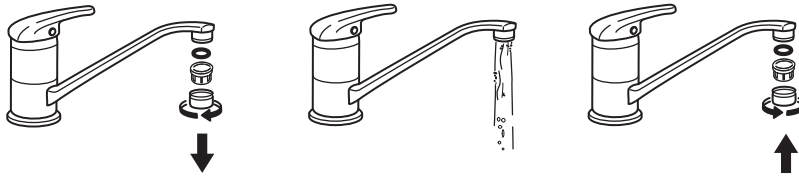

English

Before use: Unscrew the Aerator/Flow Guide and allow the water to run freely for a few minutes. Then screw the Aerator/Flow Guide back in place. Ensure that it is tight to prevent removal by hand.

Français

Avant utilisation : dévisser l'aérateur/guide d'écoulement et laisser couler pendant quelques minutes. Puis remettre l'aérateur/guide d'écoulement à sa place et le visser. Assurez-vous qu'il est assez serré pour ne pas être retiré à la main.

Español

Antes de utilizarlo: desenrosca el aireador/guía de desagüe y deja correr el agua libremente durante unos minutos. A continuación enróscalo de nuevo. Comprueba que está bien apretado, como para no poderlo retirarlo a mano.



English

Check at regular intervals to make sure that the installation is not leaking.

Français

Vérifier à intervalles réguliers que l'installation ne fuit pas.

Español

Comprobar a intervalos regulares que la instalación no gotee.