

# NOMINELL

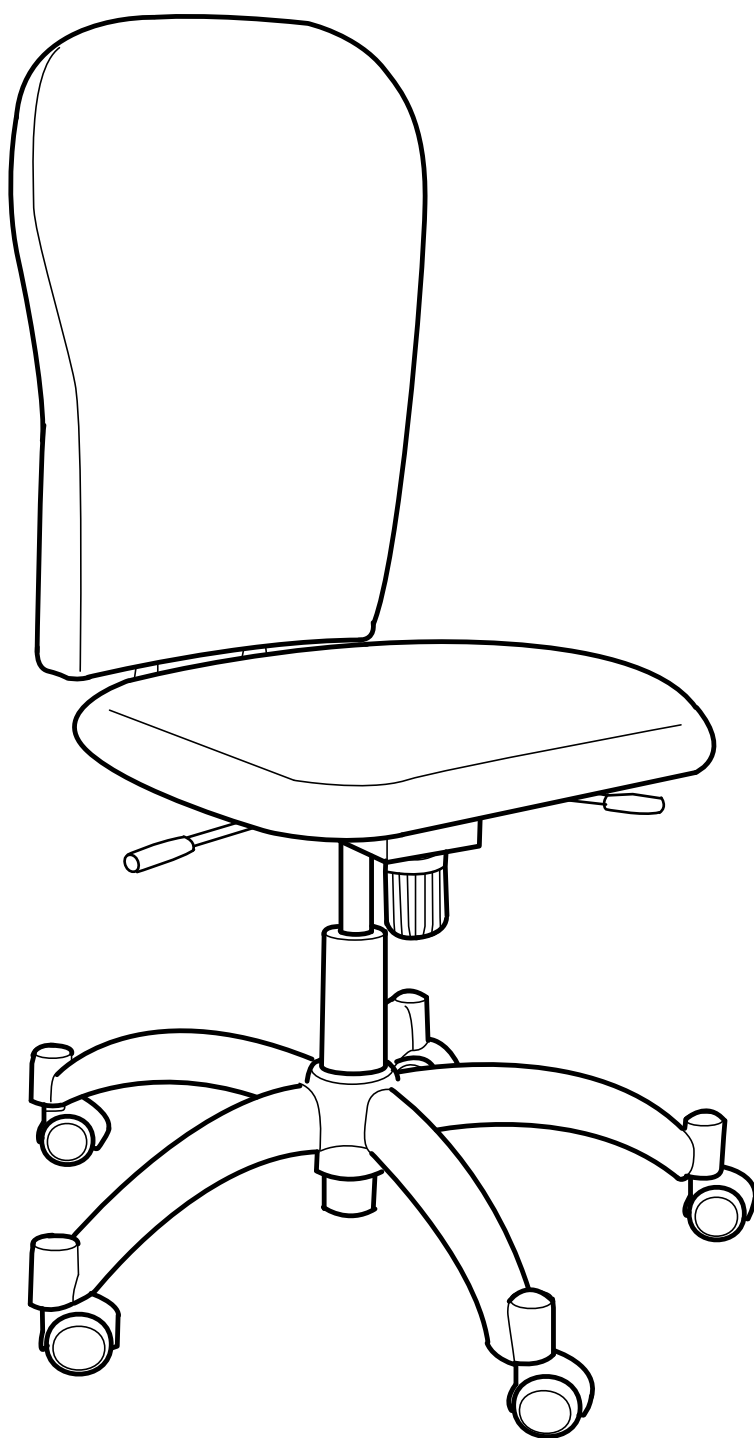

Design and Quality  
IKEA of Sweden

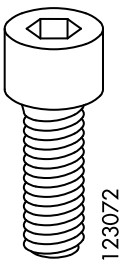
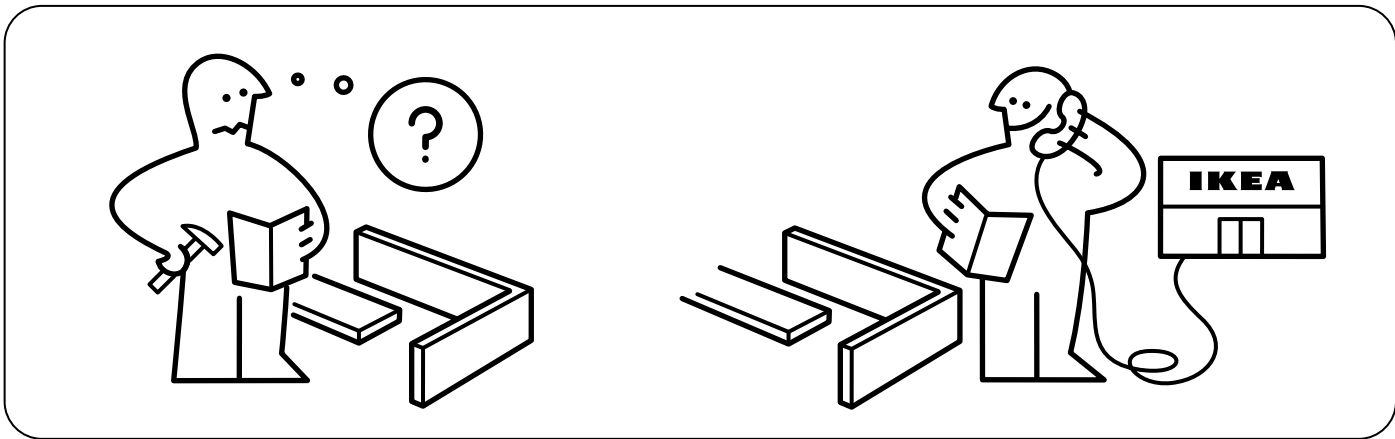
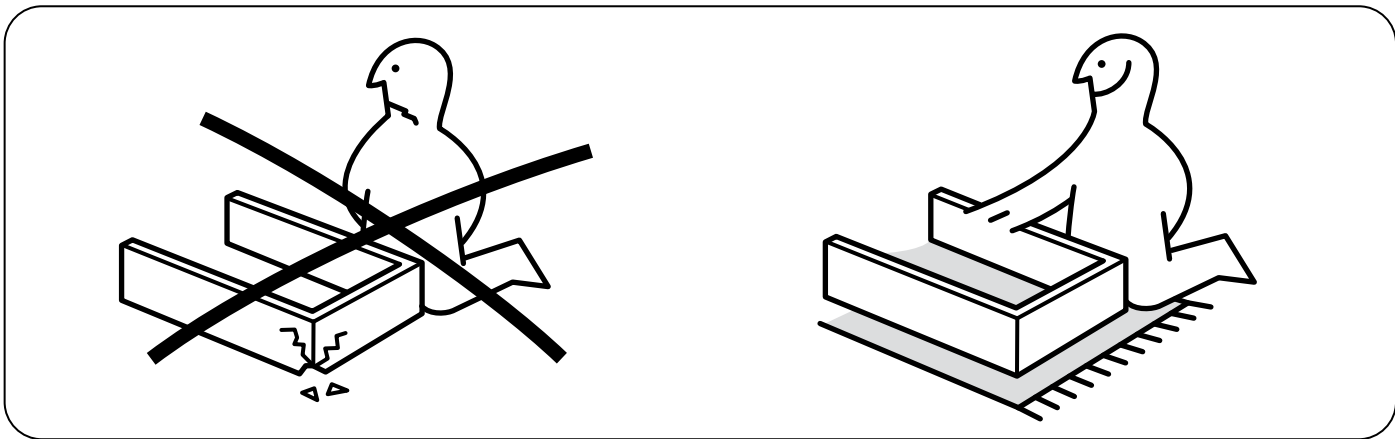

123072

4x

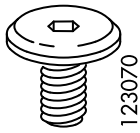

123070

4x

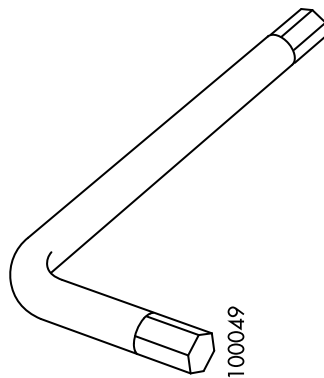

100049

1x

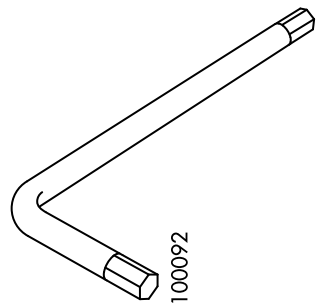

100092

1x

1

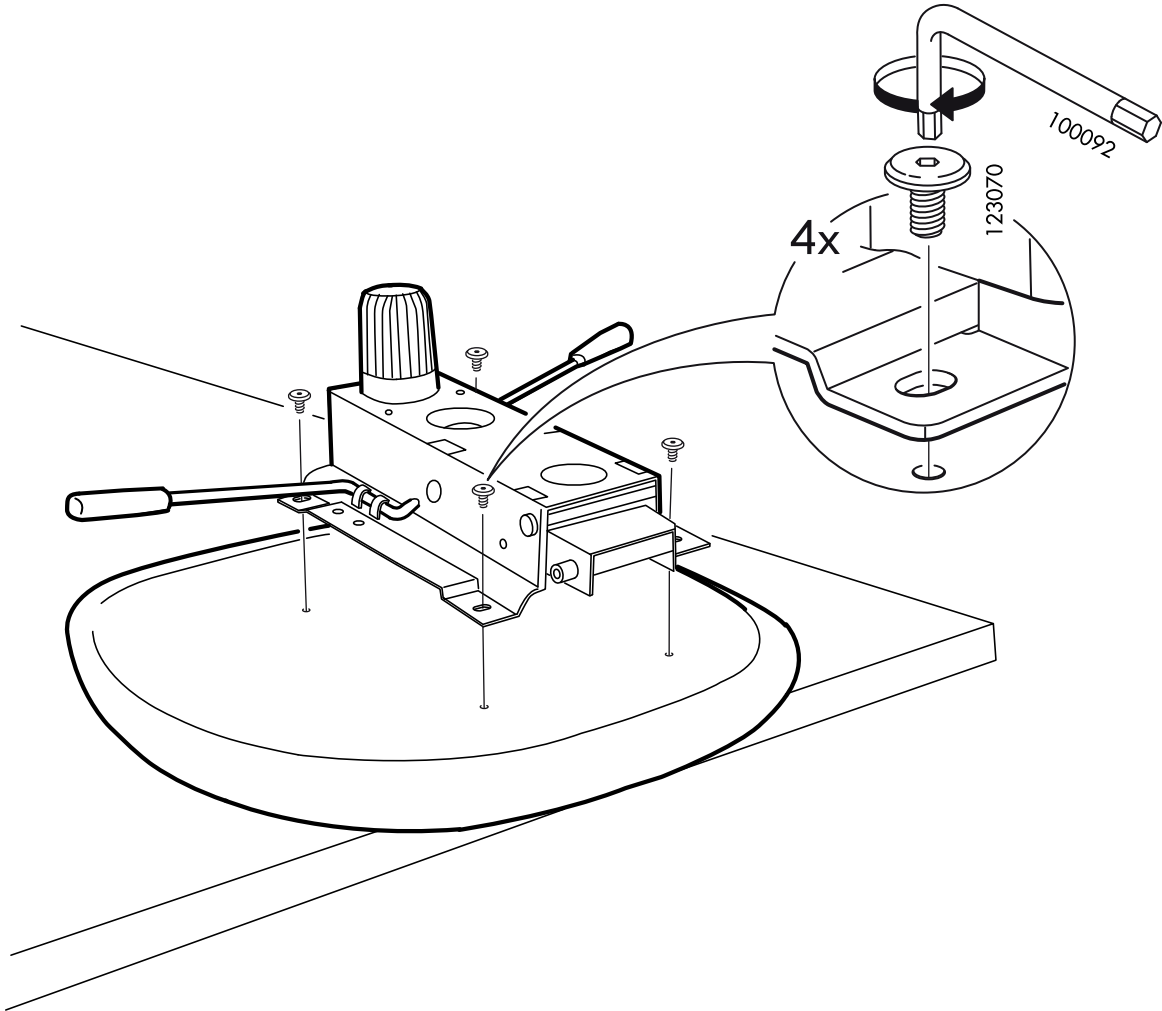

2

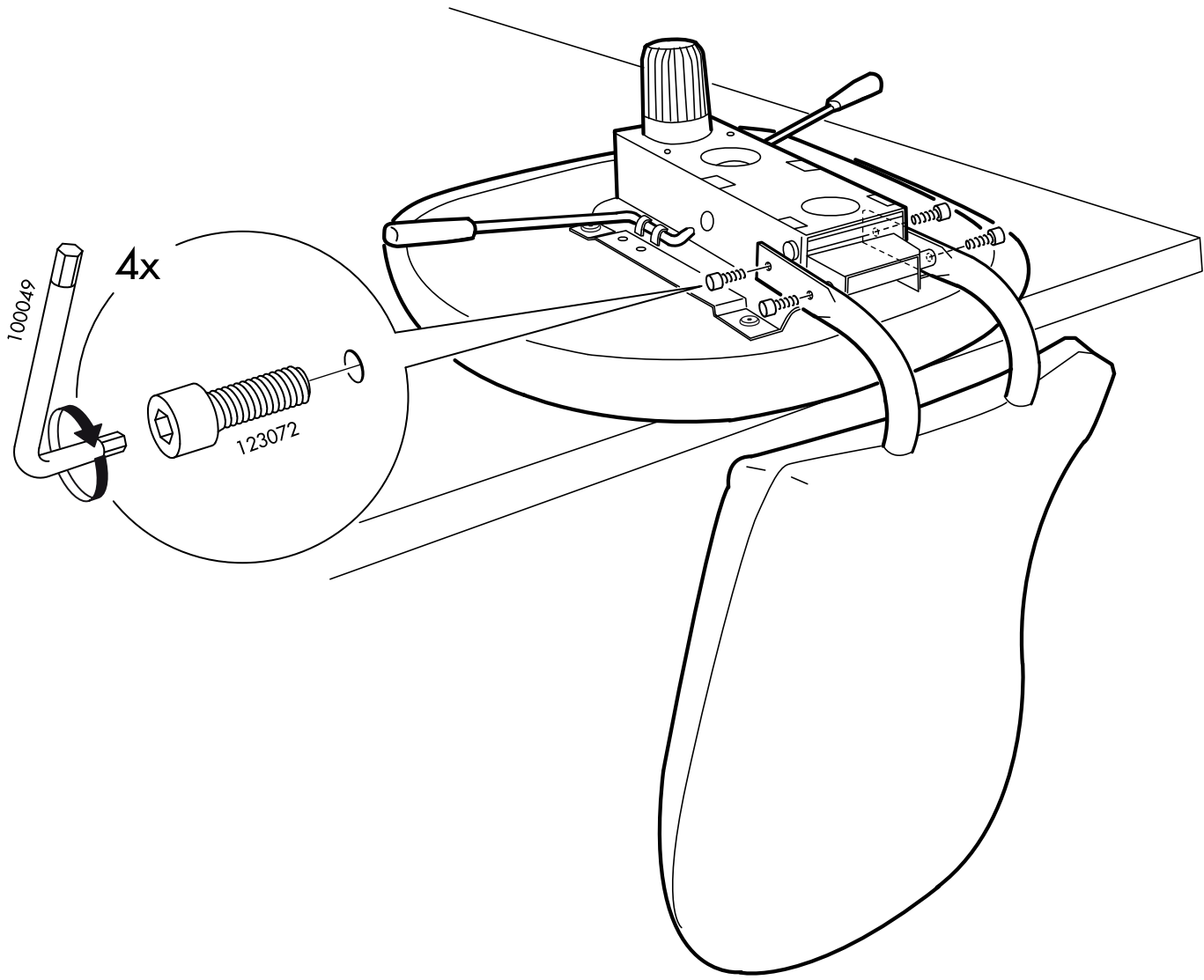
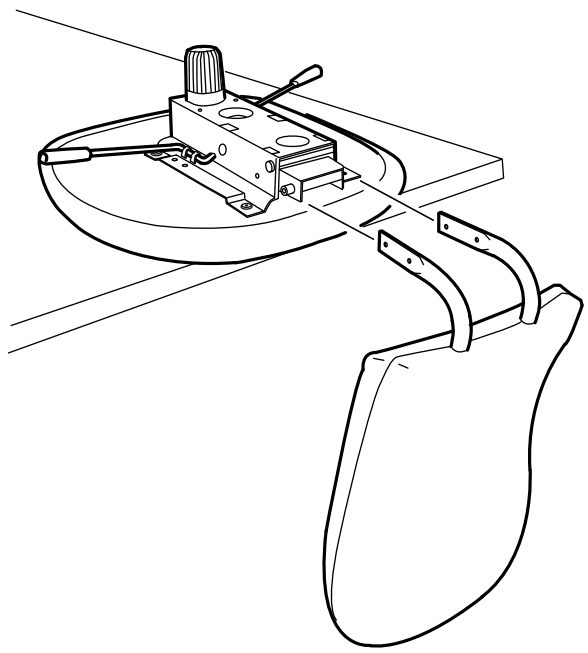

**3**

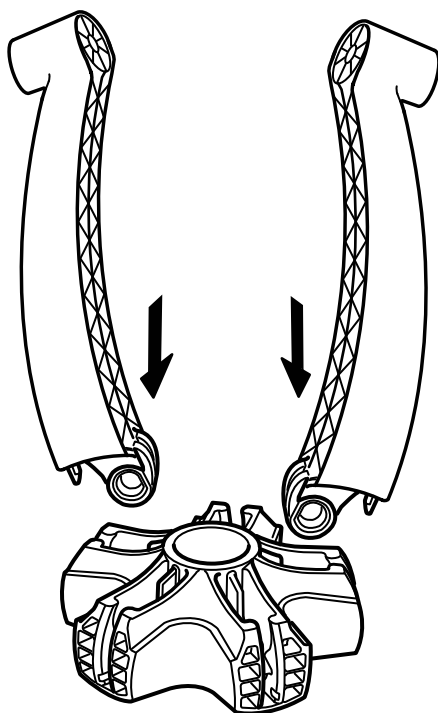

**4**

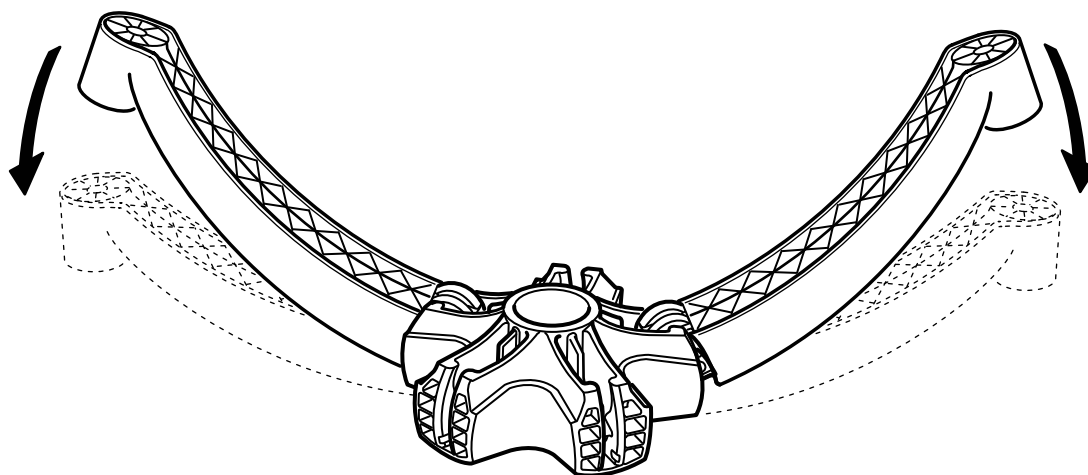

**5**

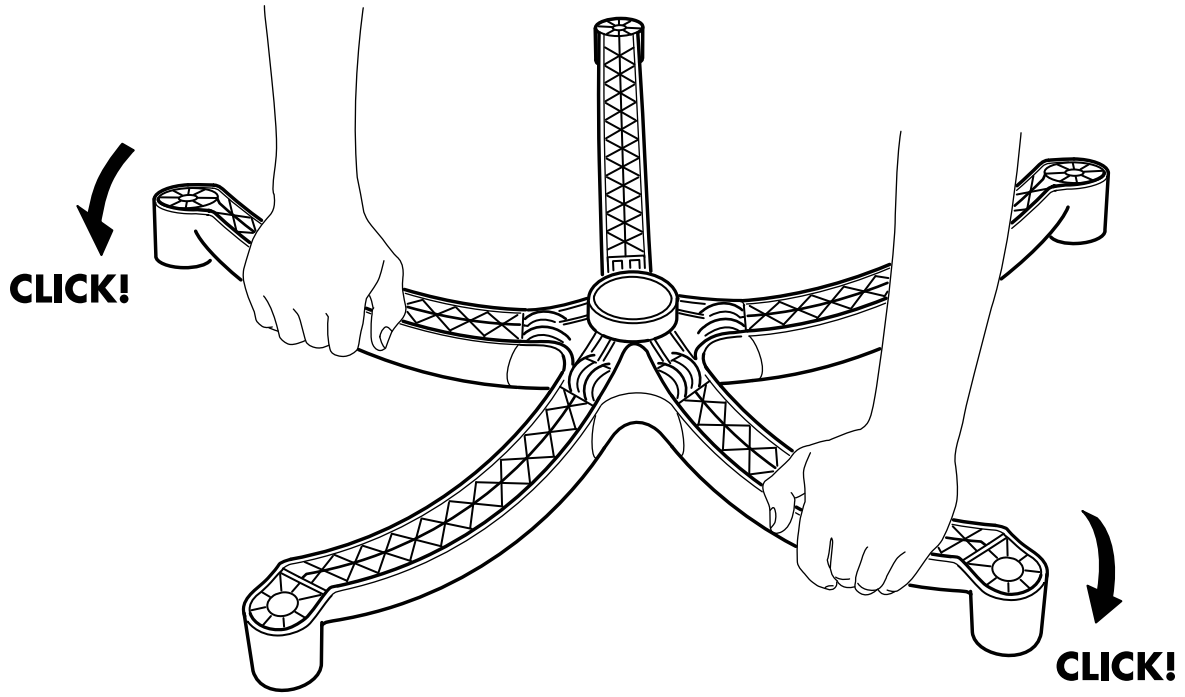

**6**

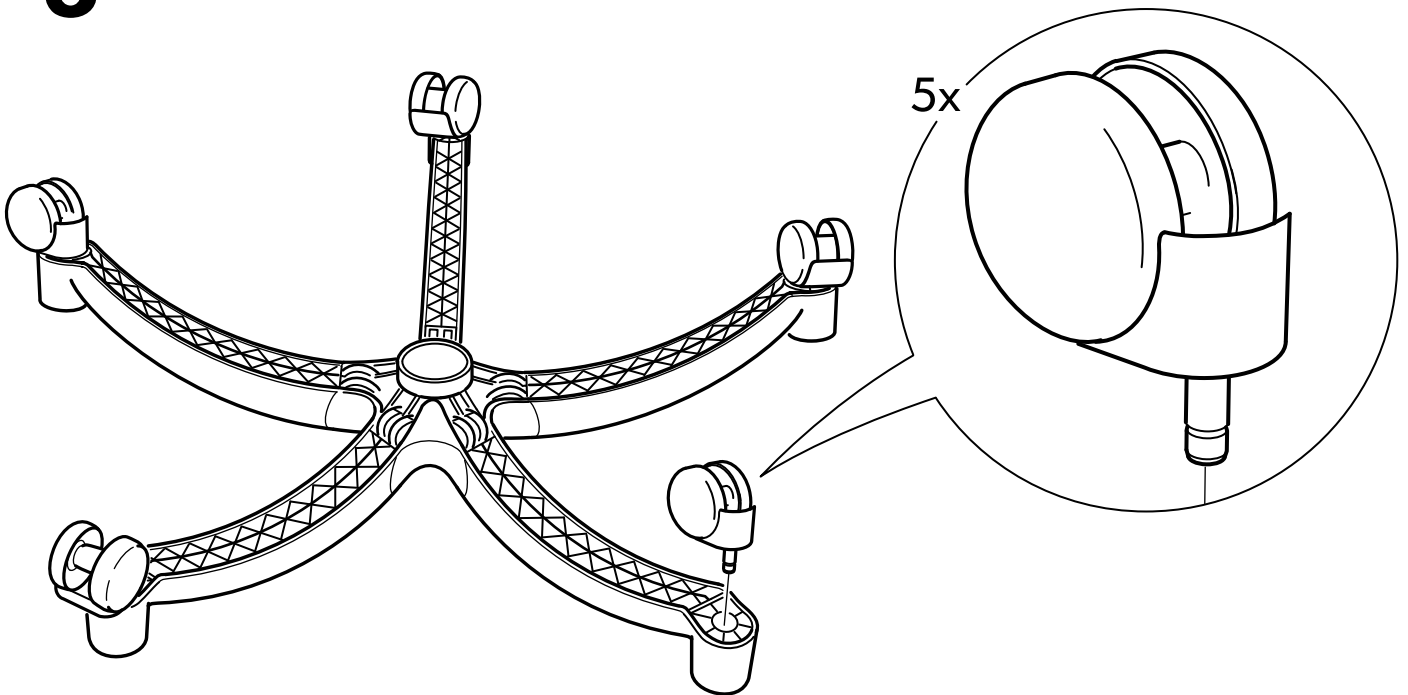

7

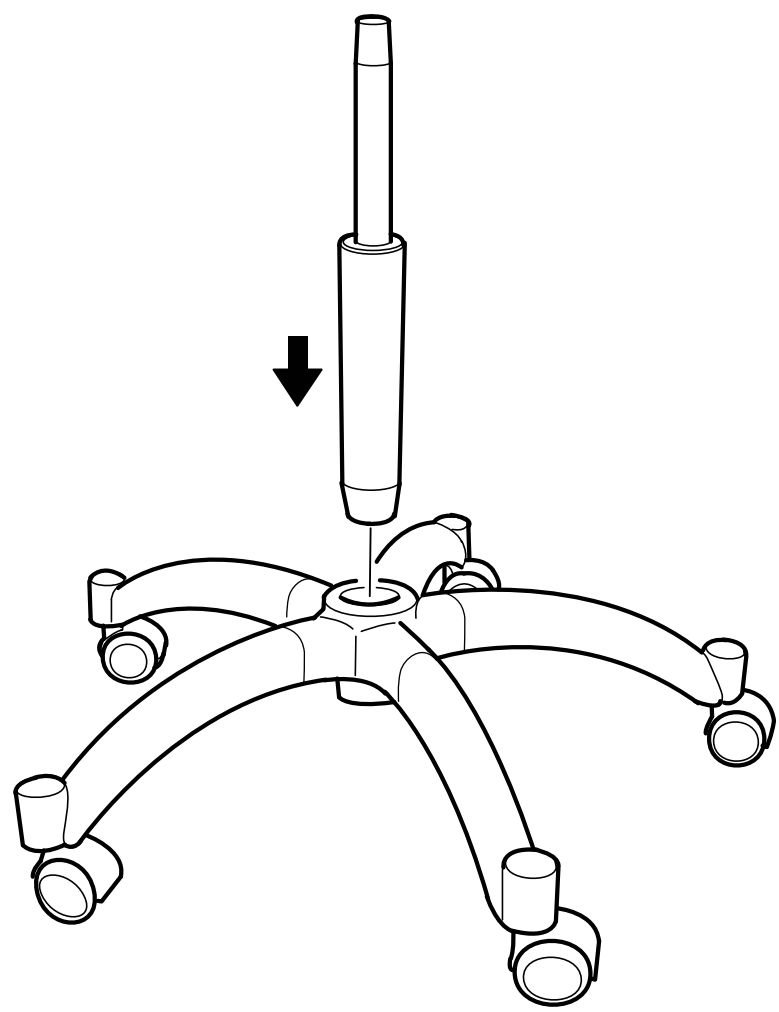
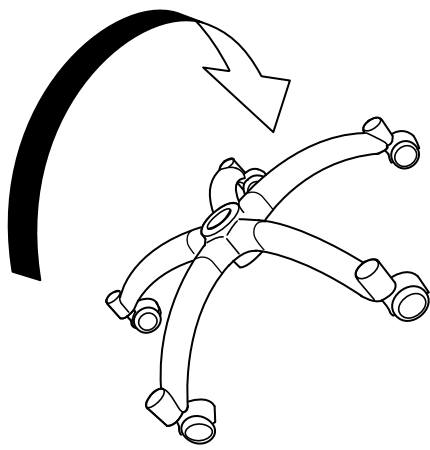

8

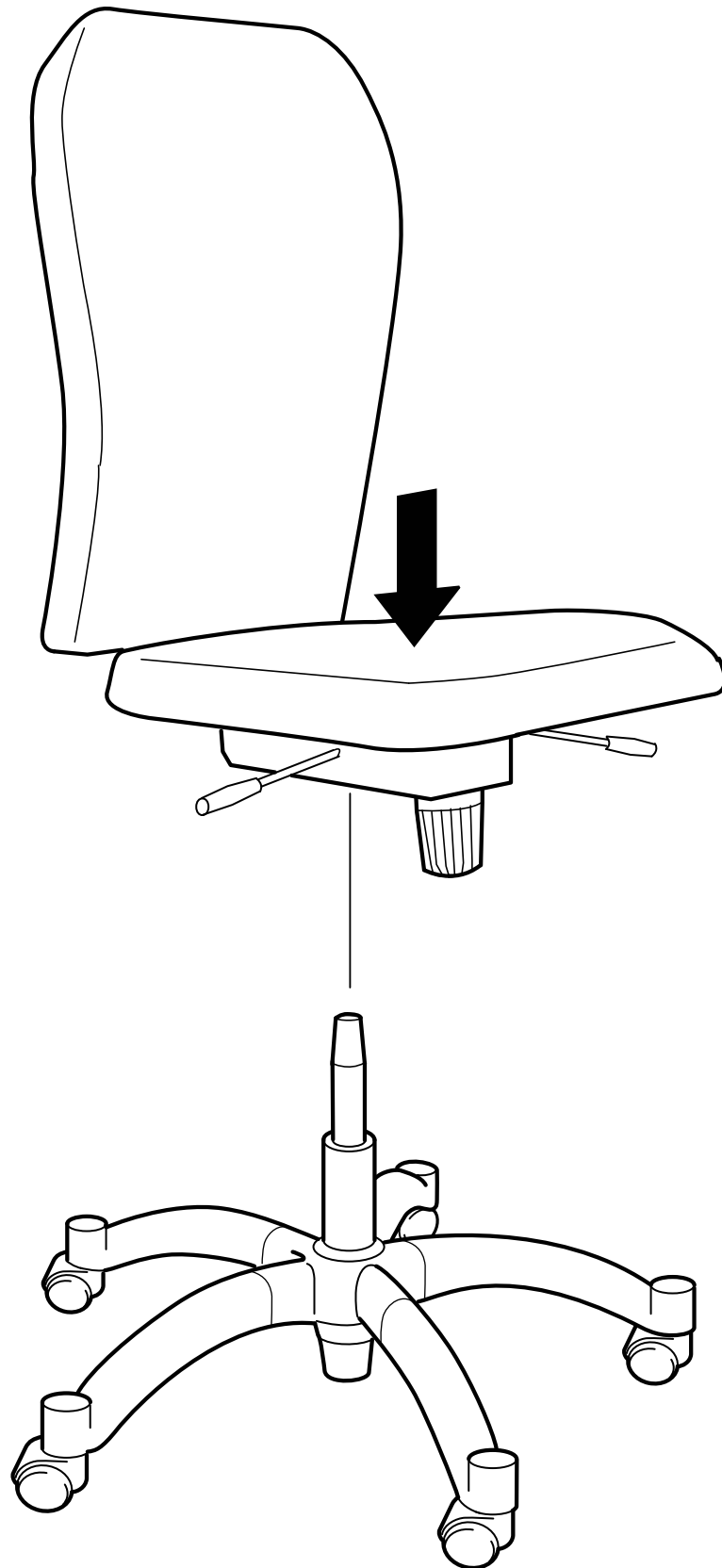



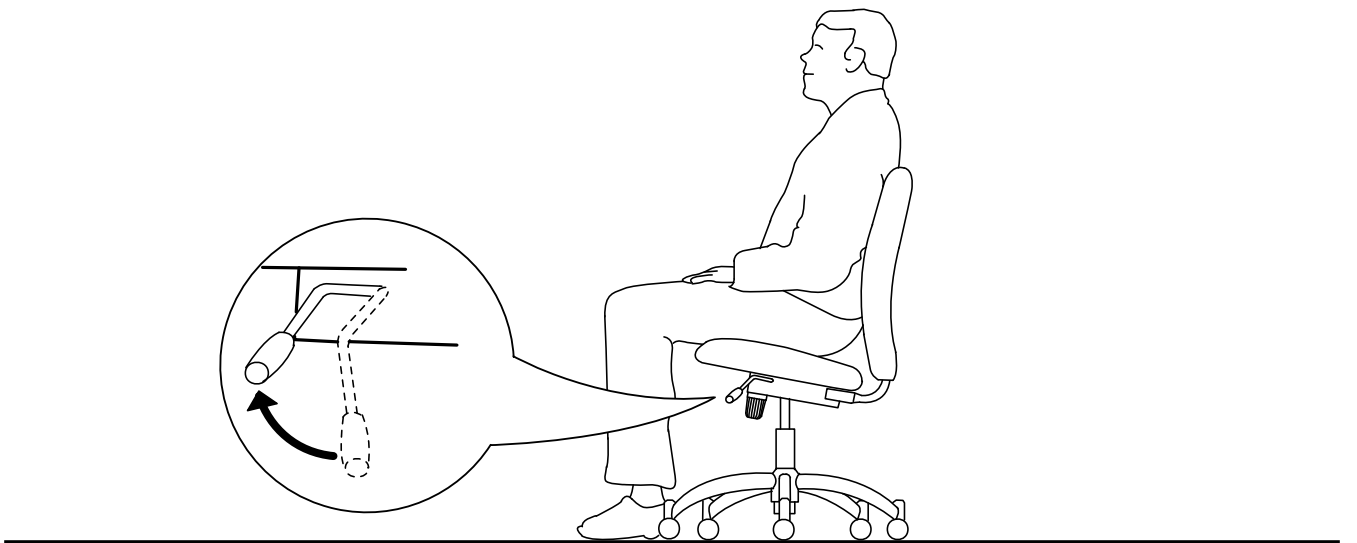
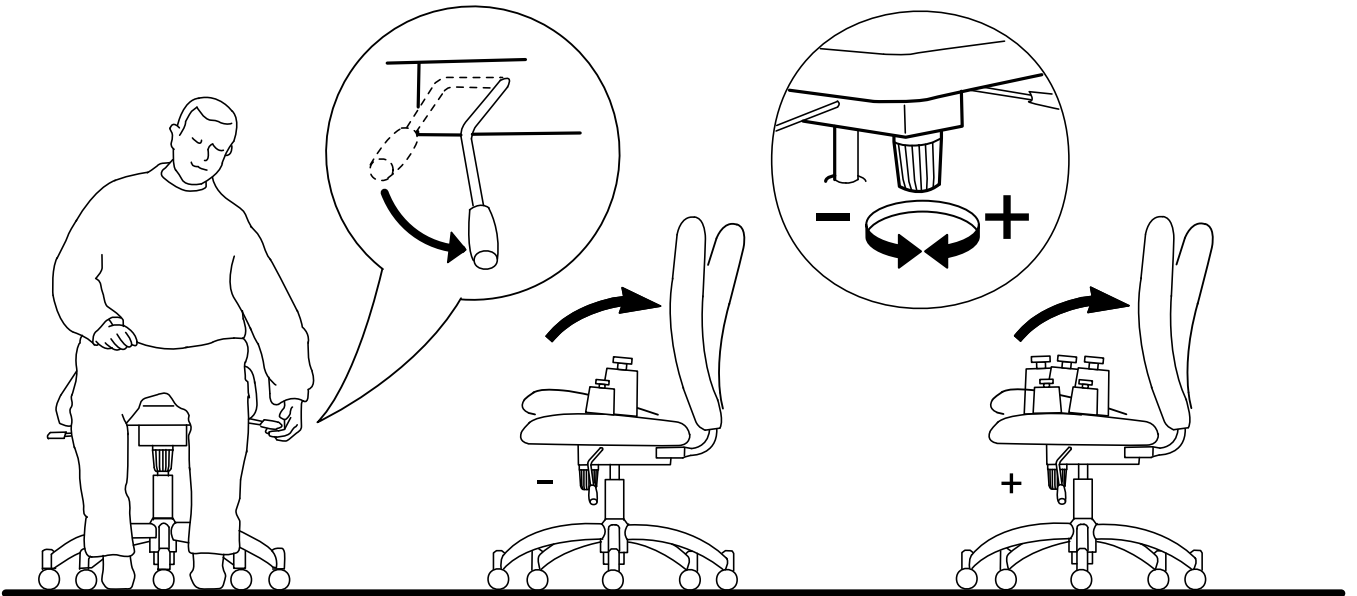
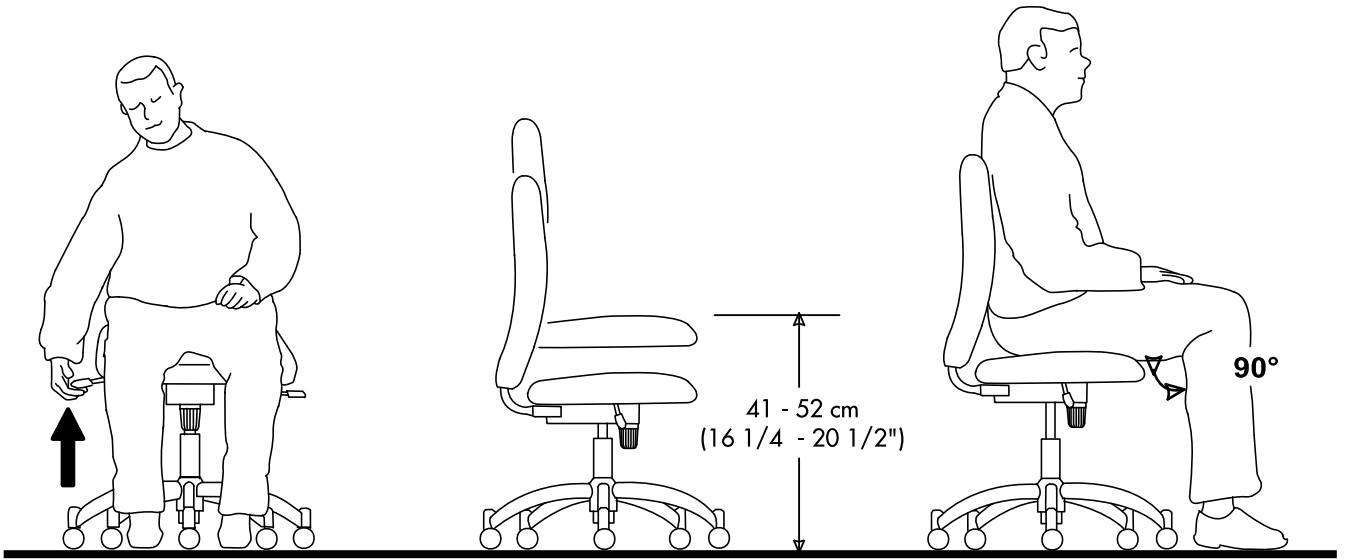

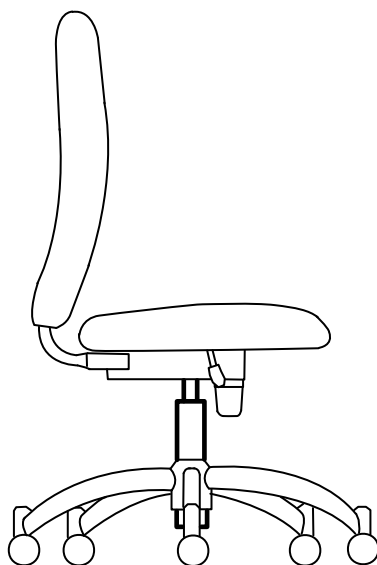
**ENGLISH**

Do not try to replace or repair.

**DEUTSCH**

Nie selbst austauschen oder reparieren.

**FRANÇAIS**

Ne pas essayer de remplacer ou de réparer.

**NEDERLANDS**

Niet proberen te vervangen of repareren.

**DANSK**

Må ikke udskiftes eller repareres.

**NORSK**

Forsøk aldri å bytte ut eller reparere selv.

**SUOMI**

Älä yrittä vaihtaa tai korjata.

**SVENSKA**

Försök aldrig ersätta eller laga själv.

**ČESKY**

Nesnažte se vyměnit nebo opravit.

**ESPAÑOL**

No intentes repararlo o reemplazarlo.

**ITALIANO**

Non effettuare alcuna sostituzione o riparazione.

**MAGYAR**

Ne próbáld meg kicserélni vagy megjavítani!

**POLSKI**

Nie próbuj wymieniać, ani naprawiać.

**PORTUGUÊS**

Não tente reparar nem substituir.

**ROMÂNĂ**

Nu încerca să schimbi sau să reparați.

**SLOVENSKY**

Nepremiestňujte ani neopravujte.

**БЪЛГАРСКИ**

Не подменяйте и не ремонтирайте.

**HRVATSKI**

Ne zamijenjujte ili popravljajte.

**ΕΛΛΗΝΙΚΑ**

Μην προσπαθήσετε να το αντικαταστήσετε ή να το επισκευάσετε.

**РУССКИЙ**

Не пытайтесь заменить или отремонтировать.

**SRPSKI**

Nemojte pokušati da popravite ili zamenite.

**SLOVENŠČINA**

Ne poskušajte zamenjati ali popraviti.

**TÜRKÇE**

Parçaları değiştirmeye veya tamir etmeye çalışmayınız.

**中文**

请勿自行更换或维修。

**繁中**

不可試圖更換或維修。

**日本語**

パーツをほかのもので代用したり、自分で修理しないでください。

**BAHASA MALAYSIA**

Jangan cuba menggantikan atau membaikinya.

**عربي**

لا تحاول إستبداله أو إصلاحه.

**ไทย**

อย่าพยายามซ่อมหรือเปลี่ยนใหม่



