

SKYTTA

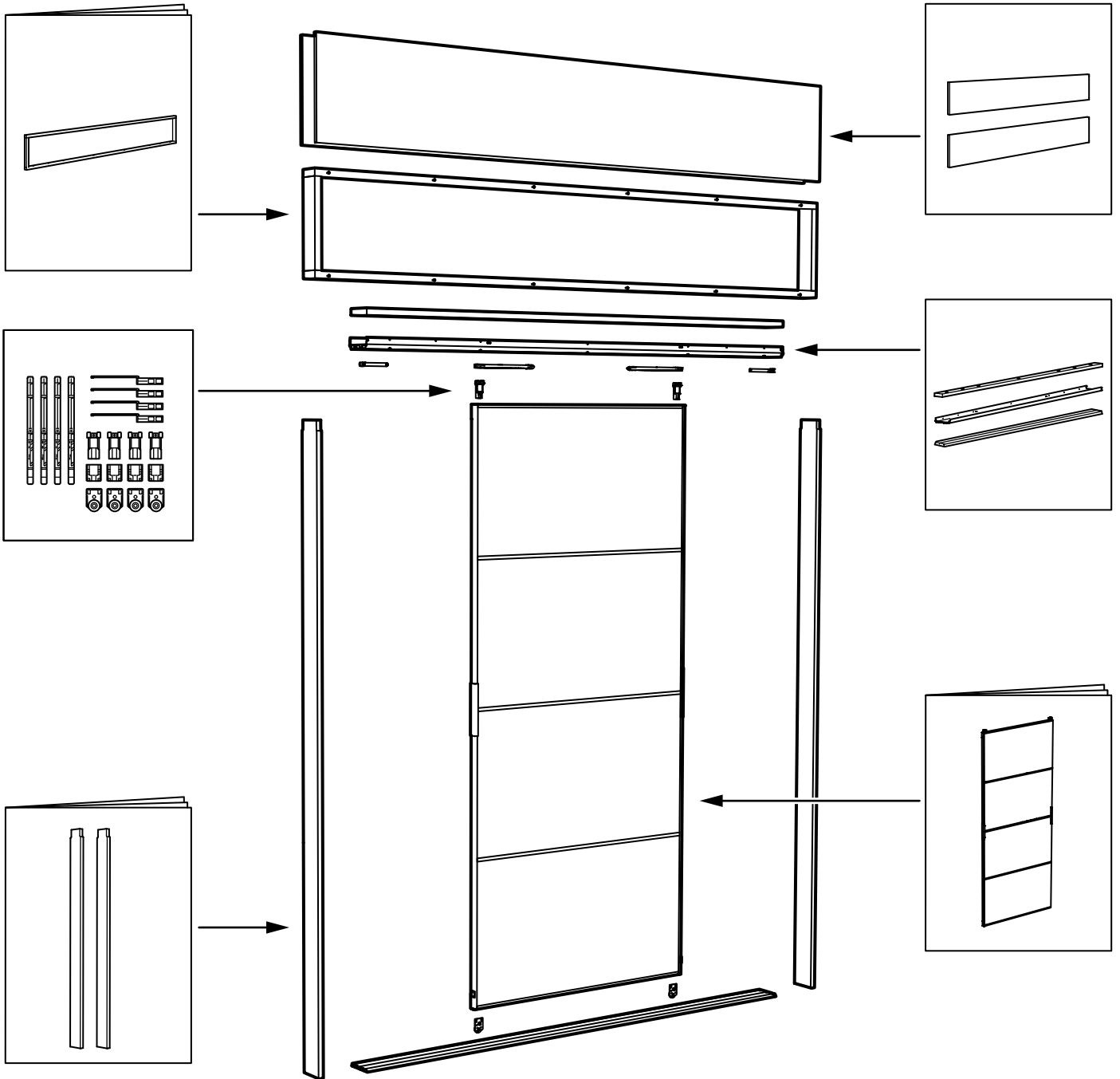

Design and Quality
IKEA of Sweden

English

NOTE! Screws or fittings to fix the furniture/object to the wall/ceiling are not included. Choose screws and fittings that are specially suited to the material in your wall/ceiling and have sufficient holding power. If you are uncertain, contact your local specialised retailer.

Deutsch

WICHTIG! Schrauben oder Beschläge zur Wand-/Deckenbefestigung sind nicht beige packt. Achten Sie darauf, dass Sie Schrauben/Beschläge entsprechend der Wand-/Deckenbeschaffenheit und mit ausreichender Tragfähigkeit verwenden. Erkundigen Sie sich gfs. beim Eisenwarenfachhandel.

Français

ATTENTION ! Les vis et ferrures pour fixer le meuble/l'objet au mur ou au plafond ne sont pas incluses. Pensez à adapter les vis ou ferrures au matériau du mur/du plafond et au poids de l'objet. En cas de doute, demandez conseil à un vendeur spécialisé.

Nederlands

N.B. Schroeven of beslag om het meubel/voorwerp in de wand/het plafond vast te zetten, zijn niet inbegrepen. Denk er aan dat de schroeven of het beslag dat je kiest geschikt moeten zijn voor de wand/het plafond waarin ze vastgezet moeten worden, en voldoende draagkracht moeten hebben. Neem bij twijfel contact op met de lokale vakhandel.

Dansk

BEMÆRK! Skruer og rawlplugs til montering af møblet/genstanden på væggen/loftet medfølger ikke. Vælg skruer og rawlplugs, der er egnet til væg-/loftmaterialet og som har tilstrækkelig bærekraft. Hvis du er i tvivl, skal du kontakte en uddannet forhandler.

Íslenska

ATHUGIÐ! Skrufur eða festingar til að festa húsgagnid/hlutinn við vegg/loft fylgja ekki. Notið alltaf skrufur og festingar sem eru sérstaklega ætlaðar efnunum í veggnum/loftinu og hafa nægt burðarþol. Leitaðu ráða í byggingavöruverlun ef þú ert í vafa.

Norsk

OBS! Skruer eller festebeslag til å feste møbelet/objektet til veggen/taket følger ikke med. Pass på at de skruene/festebeslagene du bruker er beregnet for det materialet de skal festes i, samt at de har tilstrekkelig bærekraft. Kontakt din lokale faghandel dersom du er i tvil.

Suomi

HUOM! Huonekalun/esineen seinään/kattoon kiinnittämistä varten tarvittavat ruuvit/kiinnikkeet eivät sisälly pakkaukseen. Ota huomioon ruuveja/kiinnikkeitä valitessasi seinän/katon laatu ja että ruuveilla/kiinnikkeillä on riittävä kantavuus. Jos olet epävarma ruuvien/kiinnikkeiden valinnassa, ota yhteys paikalliseen rautakauppaan.

Svenska

OBS! Skruvar eller fästbeslag att fästa möbelen/föremålet i väggen/taket medföljer ej. Tänk på att skruvarna eller fästbeslagen du väljer ska vara avsedda för väggen/taket de ska fästa i, samt ha tillräcklig bärkraft. Är du osäker kontakta din lokala fackhandel.

Česky

UPOZORNĚNÍ! Šrouby nebo kování, které jsou zapotřebí k připevnění nábytku/věcí ke stěně/stropu, nejsou součástí balení. Použijte šrouby nebo kování, které jsou vhodné do dané stěny/stropu a mají dostatečnou hmotnost. Nejste-li si jisti, obraťte se na nejbližší specializovaný obchod.

Español

¡ATENCIÓN! No se incluyen los tornillos o herrajes para sujetar el mueble/elemento en la pared/el techo. Recuerda que los tornillos o herrajes que elijas deben ser los adecuados para la pared/el techo en donde irán sujetos, y que tenga la resistencia suficiente. Si no estás seguro, ponte en contacto con tu tienda especializada.

Italiano

N.B. Le viti e gli accessori per fissare il prodotto alla parete/al soffitto non sono inclusi. Scegli viti e accessori di fissaggio in grado di sostenere il peso del prodotto in questione e adatti alla parete/al soffitto a cui l'articolo va fissato. Se hai dei dubbi, rivolgiti a un rivenditore specializzato.

Magyar

FIGYELEM! A fali / mennyezeti rögzítéshez szükséges csavarokat, alkatrészeket külön kell megvásárolnod. Mindig válassz olyan csavart, rögzítőt, tiplit, mely leginkább alkalmas az otthonodban található fal minőségéhez és ellenőrizd, hogy teherbíró képessége is megfelelő legyen. Ha bizonytalan vagy, kérj tanácsot az eladótól az IKEA- ban.

Polski

UWAGA! Wkręty lub zamocowania potrzebne do przymocowania mebla/obiektu do ściany/sufitu nie zostały zawarte w komplecie. Wybieraj zawsze wkręty i zamocowania, które są odpowiednie do twojej ściany/sufitu i mają wystarczającą wytrzymałość. W przypadku jakichkolwiek wątpliwości należy skontaktować się z lokalnym specjalistą w sklepie.

Eesti

TÄHELEPANU! Tootega pole kaasas kruvisid ega muid kinnitusvahendeid (mööbli)esemete seinale/lakke kinnitamiseks. Valige alati kinnitusvahendid, mis sobivad teie sein-/laematerjaliga ning millel on piisav kandevõime. Asjakohase informatsiooni saamiseks pöörduge tööriistapoodi.

Latviešu

UZMANĪBU! Skrūves un stiprinājumi mēbeļu/priekšmetu tie jāizvēlas atkarībā no konkrētā sienu/griestu materiāla. Izvēlieties skrūves un stiprinājumus, kas ir piemēroti konkrētajam sienu/griestu materiālam un spēj izturēt tiem paredzēto slodzi. Šābu gadījumā konsultējieties ar speciālistu.

Lietuvių

DĖMESIO! Varžtai ar baldų/gaminio tvirtinimo prie sienos/lubų detalės nepriedamos. Visada rinkitės varžtus ir tvirtinimo detales pagal sienų/lubų apdailos medžiagas ir atitinkamą laikomąją galią. Jei abejojate, kreipkitės į specializuotus pardavėjus.

Portugues

ATENÇÃO! Os parafusos e ferragens para fixar o móvel à parede/tecto não estão incluídos. Escolha sempre os parafusos e ferragens apropriados para o material da sua parede/tecto e que tenham suficiente capacidade de suporte. Se tiver dúvidas, contacte com um especialista.

Româna

ATENȚIE! Șuruburile și accesoriile necesare fixării obiectului/mobilei pe peretei/plafon nu sunt incluse. Alege întotdeauna șuruburi și accesorii adecvate materialului plafonului/peretelui tău și care au suficientă capacitate de susținere. Contactează retailer-ul tău local pentru consiliere.

Slovensky

UPOZORNENIE! Skrutky alebo kovanie na upevnenie nábytku/objektu na stenu/strop nie sú súčasťou balenia. Použite vždy skrutky a kovanie, ktoré sú vhodné na použitie do materiálu danej steny/stropu a majú dostatočnú nosnosť. Ak si nie ste istí, obráťte sa na špecializovaného predajcu.

Български

ВАЖНО! Винтове и фитинги за прикрепяне към стената/тавана не са осигурени. Подбирайте винтове и фитинги, които са специално съобразени с материала на вашите стени/тавани и с нужната здравина. Ако имате въпроси, свържете се със специализиран доставчик.

Hrvatski

NAPOMENA! Vijci i okovi za pričvršćivanje namještaja/predmeta na zid/strop nisu priloženi. Uvijek odaberite vijke i okove koji točno odgovaraju vrsti vašeg zida/stropa i imaju dovoljnu nosivost. Ako niste sigurni, kontaktirajte svoju lokalnu specijaliziranu prodavaonicu.

Ελληνικά

ΣΗΜΕΙΩΣΗ! Οι βίδες ή τα εξαρτήματα για την στερέωση του επίπλου/αντικειμένου στον τοίχο/ταβάνι δεν περιλαμβάνονται. Επιλέξτε βίδες και εξαρτήματα, τα οποία να είναι τα πλέον κατάλληλα για το υλικό του τοίχου ή του ταβανιού σας και τα οποία να έχουν αρκετή ικανότητα στήριξης. Εάν έχετε κάποια αμφιβολία, ελάτε σε επαφή με το ειδικευμένο κατάστημα λιανικής πώλησης της περιοχής σας.

Русский

ВНИМАНИЕ! Шурупы или крепления для фиксации мебели/предметов на стене/потолке не прилагаются. Выбирайте шурупы и крепления, которые подходят к материалу Вашей стен/потолков и которые обладают достаточной несущей способностью. В случае каких-либо сомнений обратитесь в местный специализированный магазин.

Українська

ПРИМІТКА! Шурупи та арматура для кріплення меблів/предмета до стіни/стелі не додаються. Завжди вибирайте шурупи та арматуру, які підходять для матеріалу ваших стін/стелі та мають достатню тримкість. Якщо у вас є сумніви, зверніться до найближчого спеціалізованого магазину.

Srpski

PAŽNJA! Zavrtnji ili spone za montiranje nameštaja/predmeta na zid/tavanicu ne dobijaju se uz proizvod. Odaberi zavrtnje i spone dovoljne nosivosti i da odgovaraju vrsti zida/tavanice. Ako si u nedoumici, raspitaj se u specijalizovanoj radnji.

Slovenščina

POMNI! Vijaki in vložki za pritrditev pohištva/izdelka na steno/strop niso priloženi. Uporabi take vijake in zidne vložke, ki ustrezajo sestavi zidu/stropa in imajo primerno nosilno moč. Za nasvet se obrni na najbližjo specializirano trgovino.

Türkçe

NOT! Mobilya/şeyayı duvar/tavana monte etmek için kullanılan vida veya bağlanti parçaları dahil değildir. Duvar/tavan yapı malzemenize uygun ve yeterli taşıma gücüne sahip vida ve bağlanti parçalarını seçin. Emin değilseniz ilgili araç-gereçleri satan dükkanlara başvurunuz.

中文

注意！包装内不含墙面/顶棚固定螺钉。根据具体墙体/顶棚材料，选择适用的安装螺钉，并具有足够承载力。需要时，可向当地专业人员咨询。

繁中

注意！固定家具/物品所需的螺絲或配件需另購。請選用適合家中牆壁/天花板材質及承重量的螺絲和配件。如有任何疑慮，請洽詢服務人員。

한국어

주의! 제품을 벽/천장에 고정하는 나사나 고정장치는 제품에 포함되어 있지 않습니다. 벽/천장 소재에 적합하고 충분한 고정력을 가진 나사와 고정장치를 사용하세요. 필요한 경우, 전문가에게 문의하세요.

日本語

注意！壁や天井に取り付けるためのネジやネジ固定具は含まれていません。壁や天井の材質に合わせ、十分強度を維持できるネジやネジ固定具を使用してください。ご不明の場合には、お近くの専門店にご相談ください。

Bahasa Indonesia

CATATAN! Sekrup atau kelengkapan untuk menetapkan perabot/objek pada dinding/langit-langit tidak disertakan. Pilihlah sekrup atau kelengkapan yang sesuai bahan dinding/langit-langit Anda dan cukup kuat untuk menahan. Bila Anda ragu, hubungi dealer spesialis setempat Anda.

Bahasa Malaysia

NOTA! Skru atau pelengkap untuk memasang perabot/objek ke dinding/siling tidak disertakan. Sentiasa pilih skru dan pelengkap yang paling sesuai dengan bahan binaan dinding/siling dan mempunyai cukup kuasa menahan beban. Jika anda tidak pasti, hubungi wakil penjual khusus di kawasan anda.

عربي

ملاحظة! تركيبات ومسامير لولبية لتثبيت الأثاث/الأغراض على الحائط/السقف غير مضمّنة. يتوجب استعمال المسامير والتجهيزات الملائمة للمواد في الحائط/السقف وتتمتع بإمكانية حمولة كافية. في حال الشك إتصل بالوكيل المعتمد والمتخصص.

ไทย

หมายเหตุ! สกรูสำหรับยึดเฟอร์นิเจอร์ติดผนังหรือเพดาน ไม่ได้นำมาด้วย คุณควรเลือกใช้สกรูหรืออุปกรณ์ยึด ที่มีแรงยึดเกาะมากเพียงพอ และเป็นชนิดที่เหมาะสมกับพื้นผิวที่ต้องการติดตั้ง หากคุณมีข้อสงสัยหรือไม่แน่ใจในการเลือกซื้อ กรุณาสอบถามร้านจำหน่ายอุปกรณ์ใกล้บ้าน

Tiếng Việt

LƯU Ý! Ốc vít hoặc phụ kiện lắp ráp để gắn đồ nội thất/vật dụng vào tường/trần nhà không đi kèm với sản phẩm. Hãy chọn loại ốc vít và phụ kiện lắp ráp phù hợp với chất liệu tường/trần nhà của bạn và có đủ khả năng chịu lực. Nếu bạn không chắc chắn, hãy liên hệ với cửa hàng chuyên doanh tại địa phương.

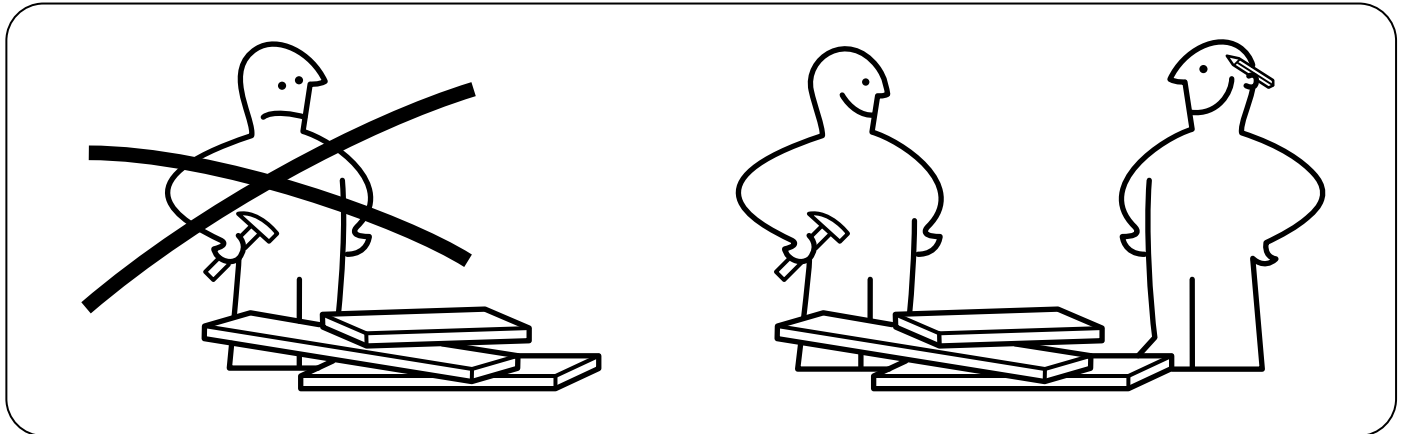
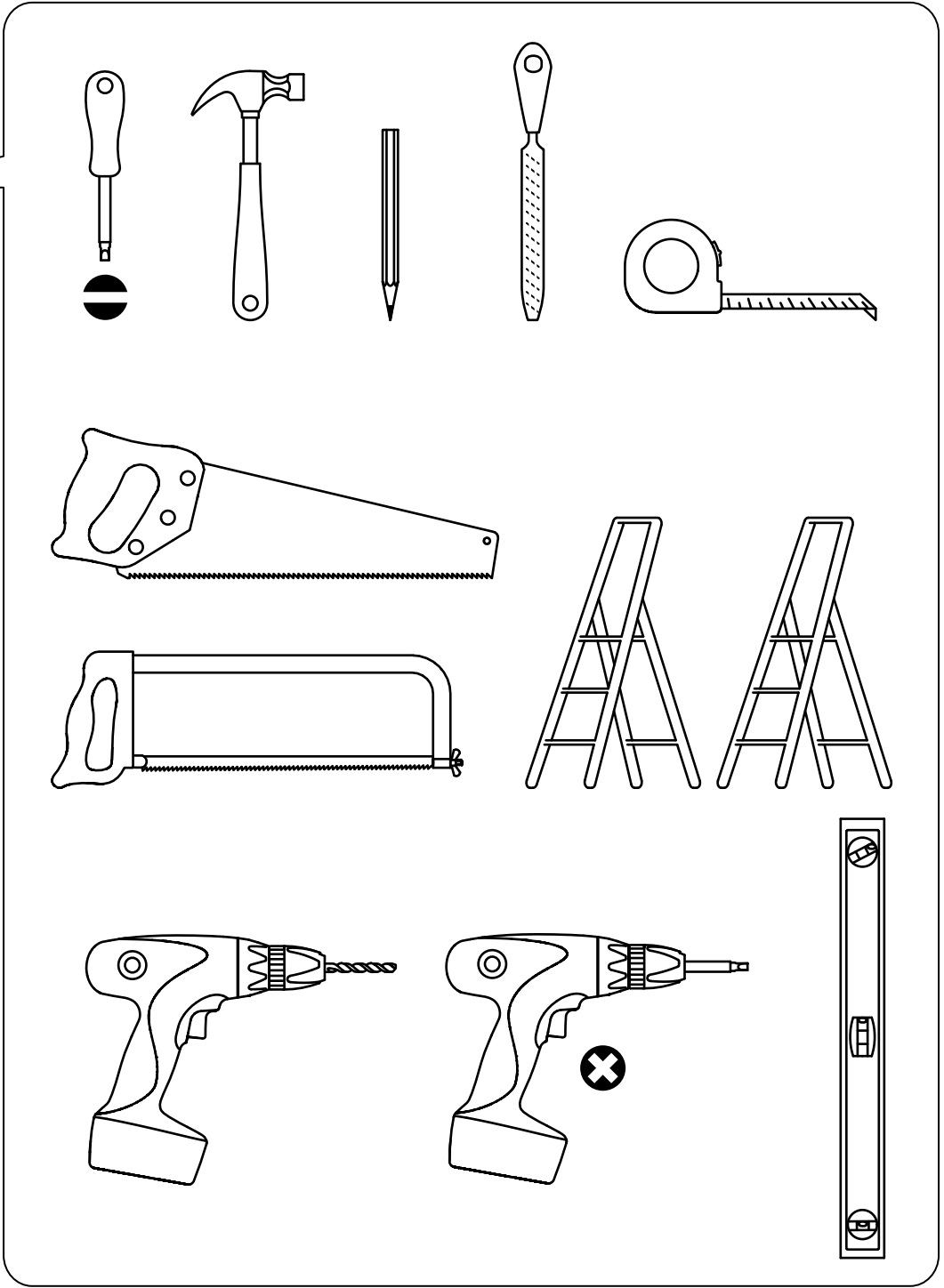
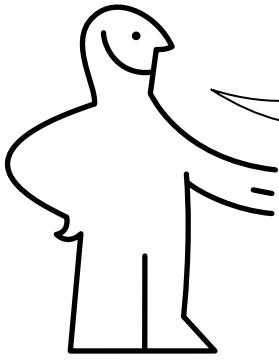

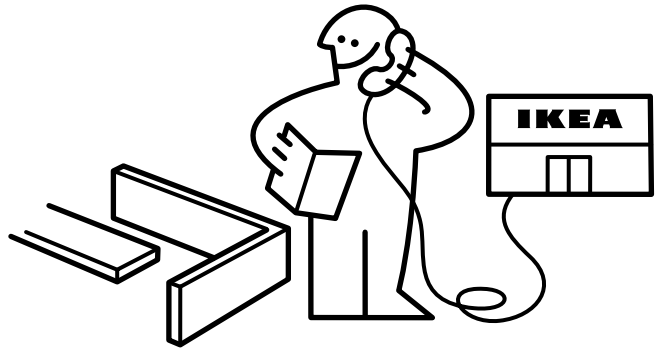
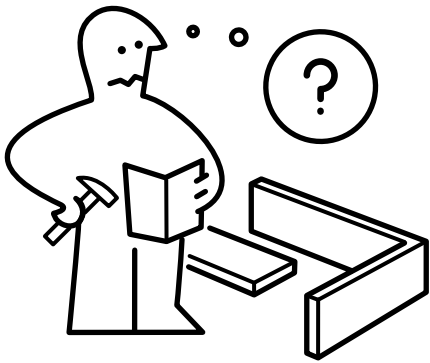
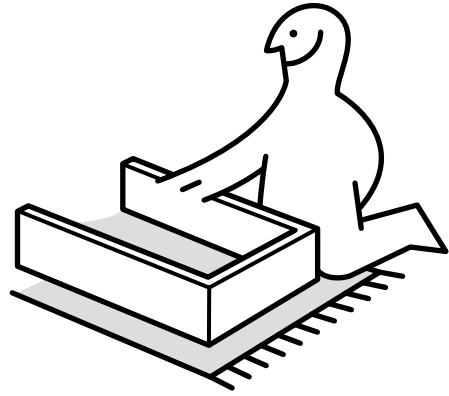
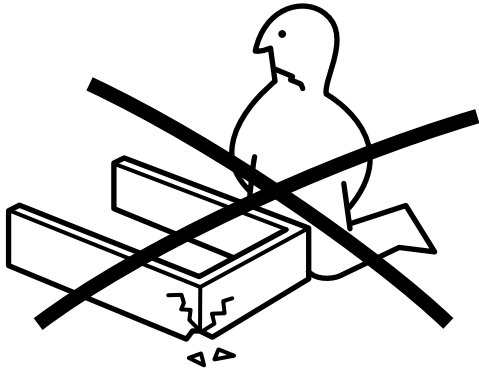

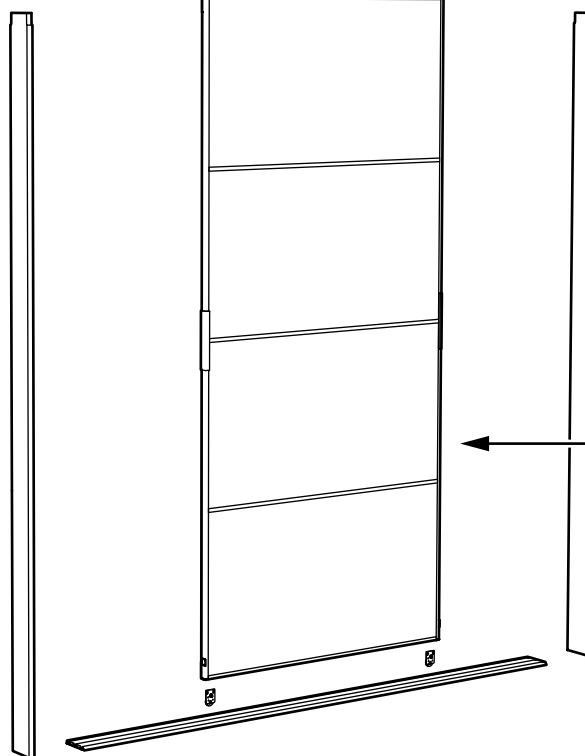
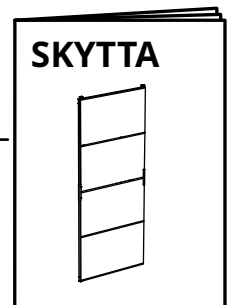
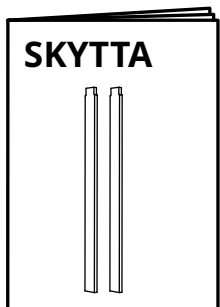
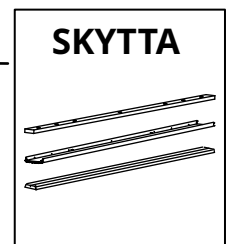
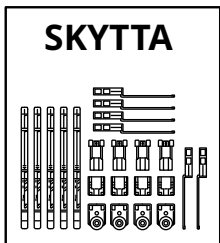
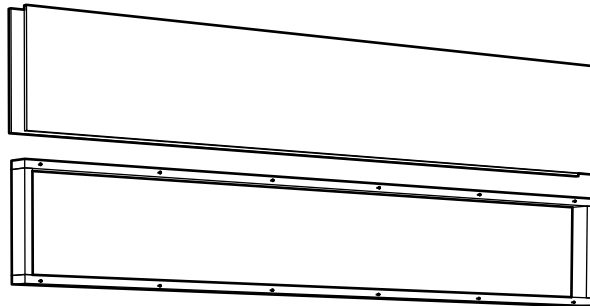
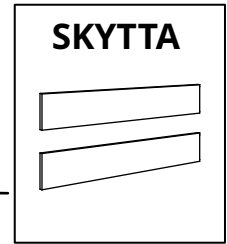
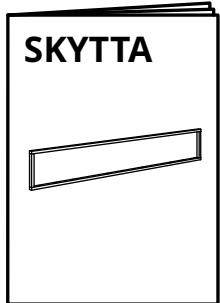

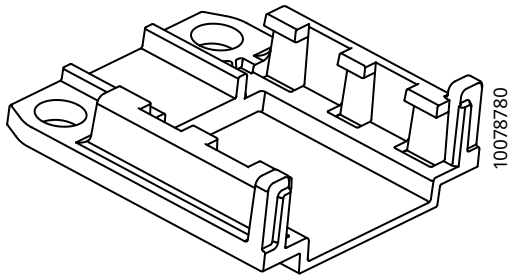

4x

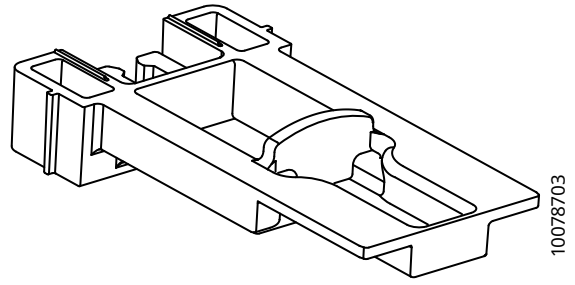

4x

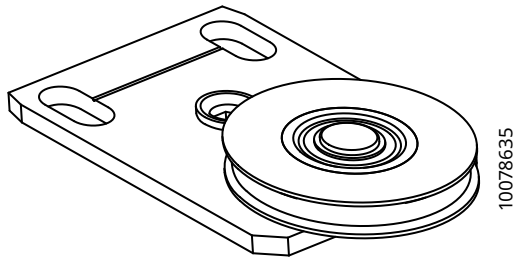

4x



6x

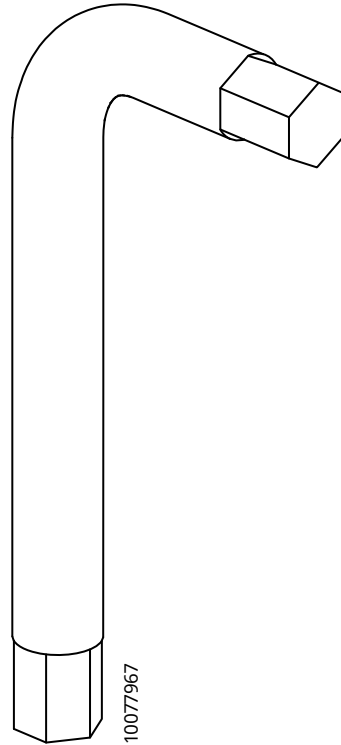

1x

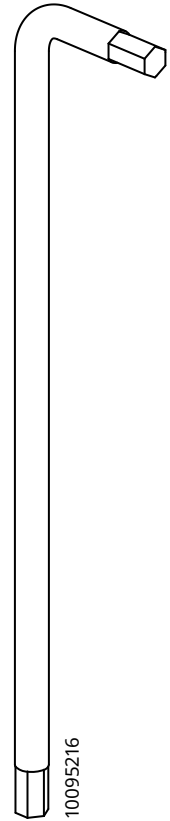

1x

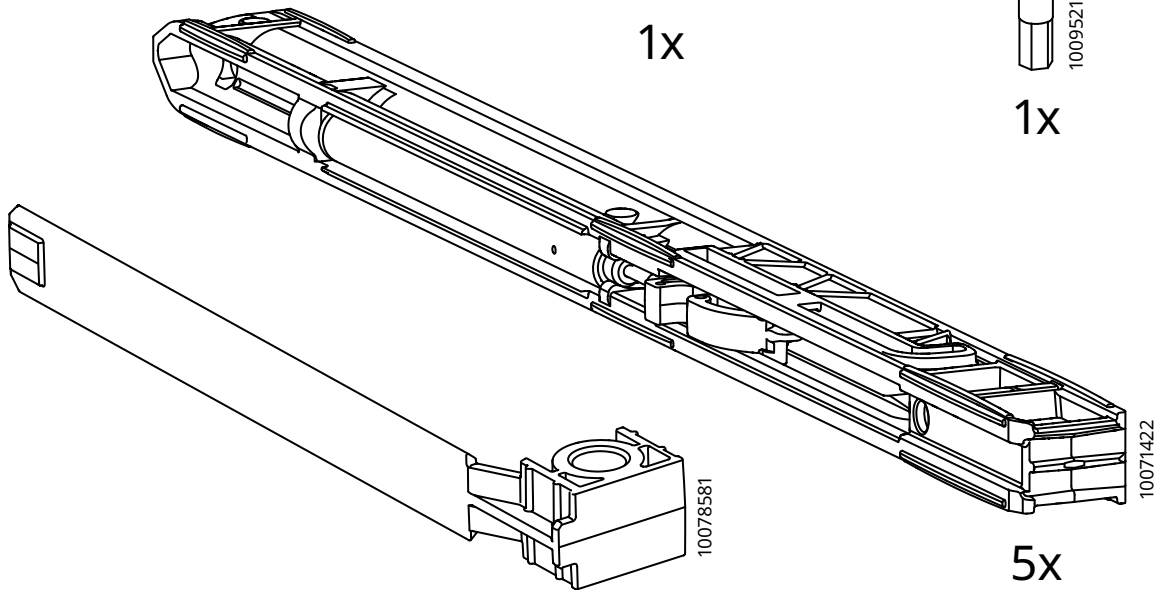



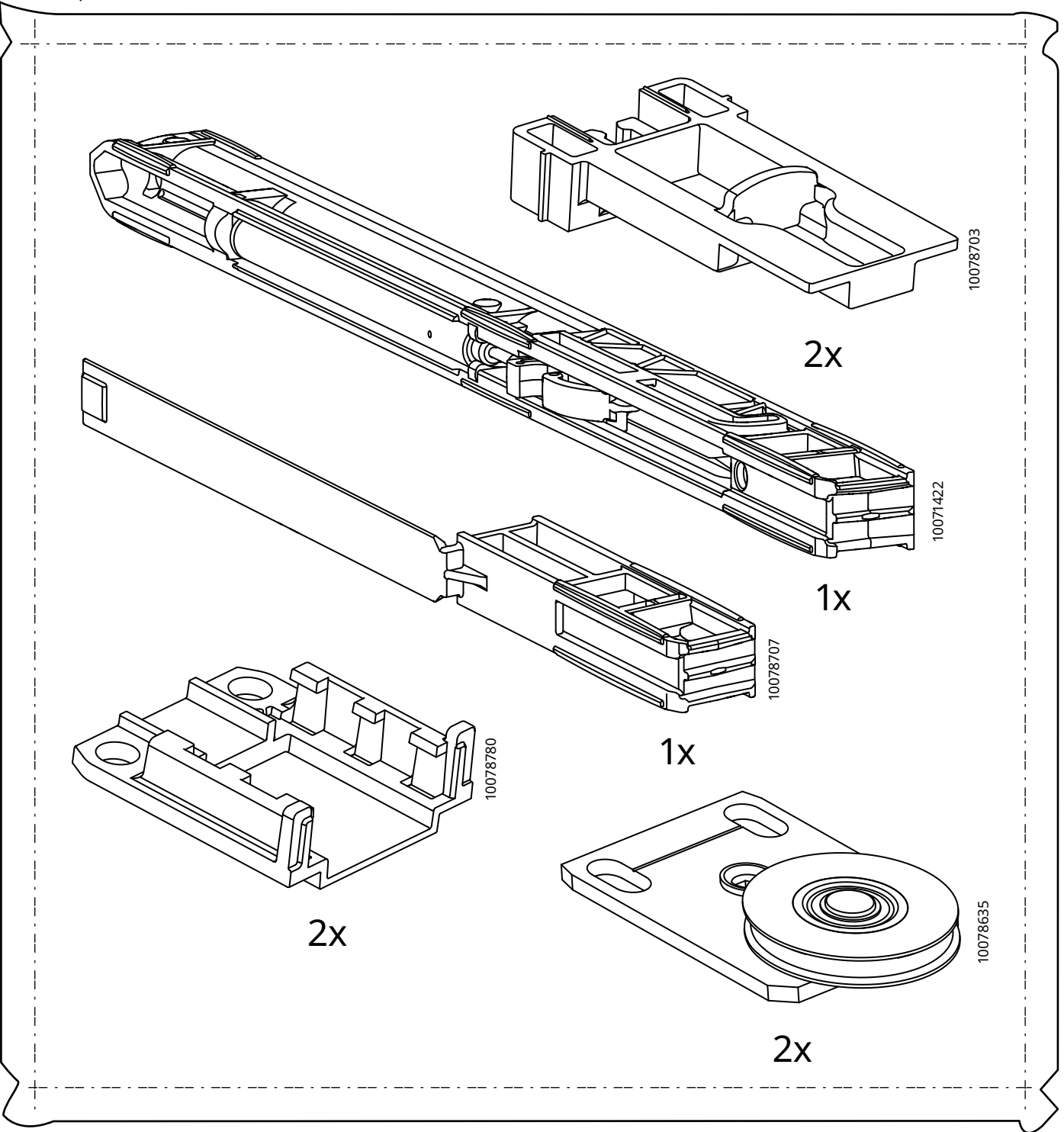
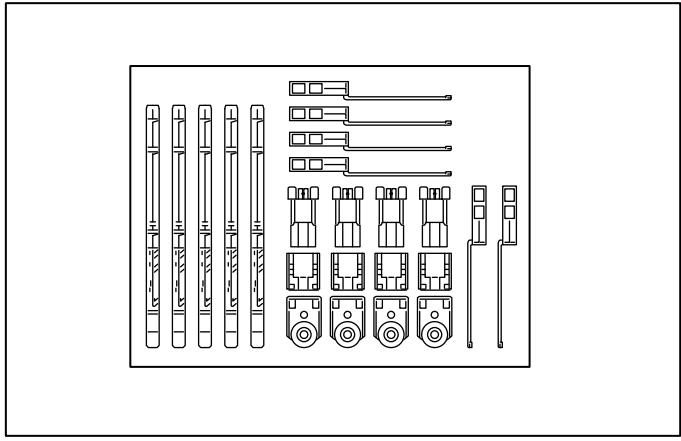
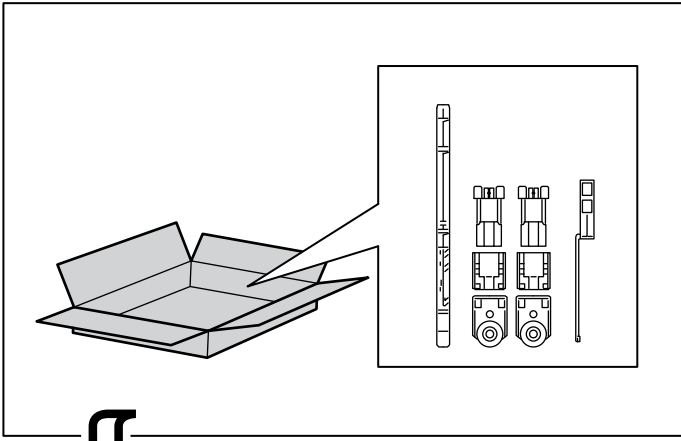

6x

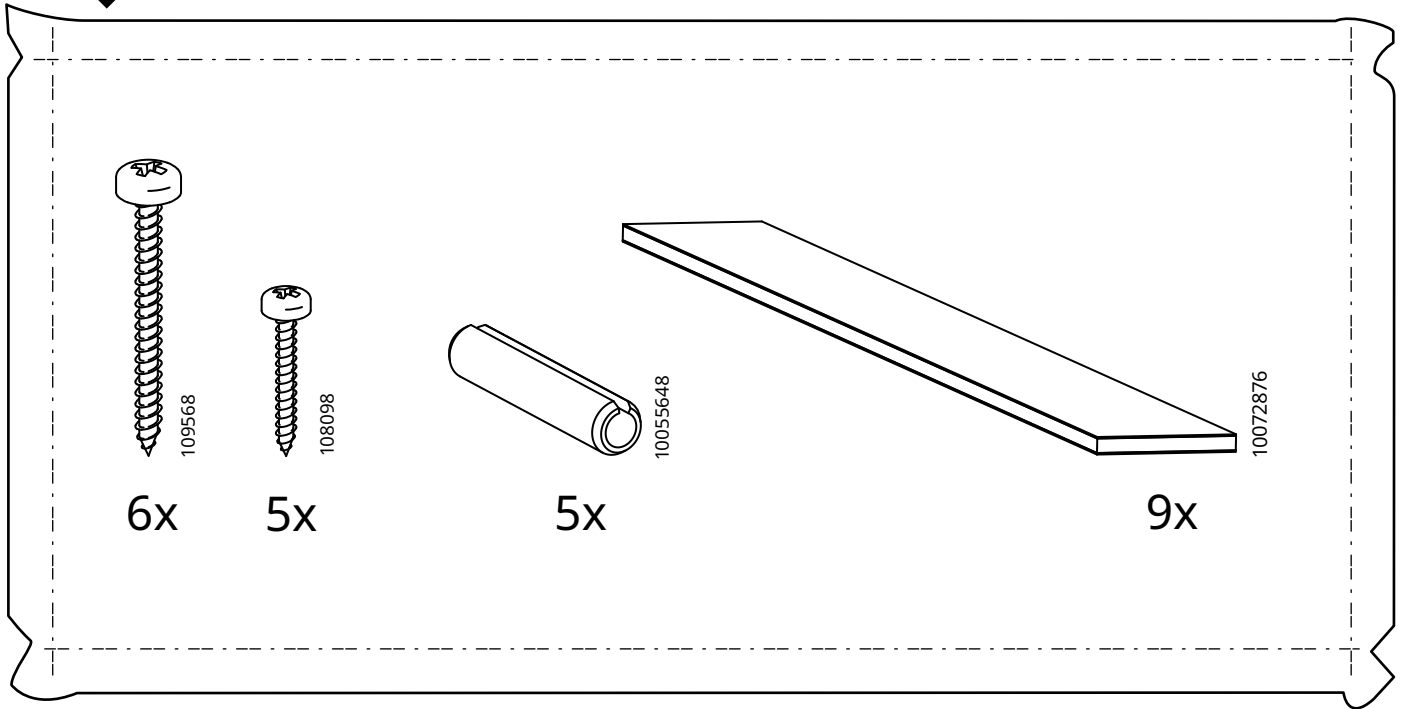
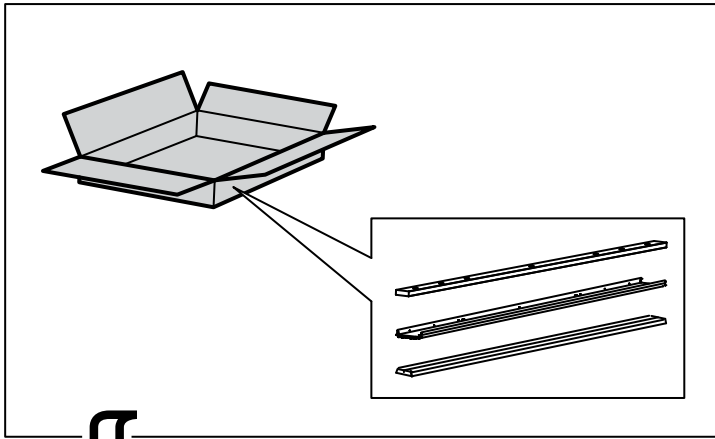
5x

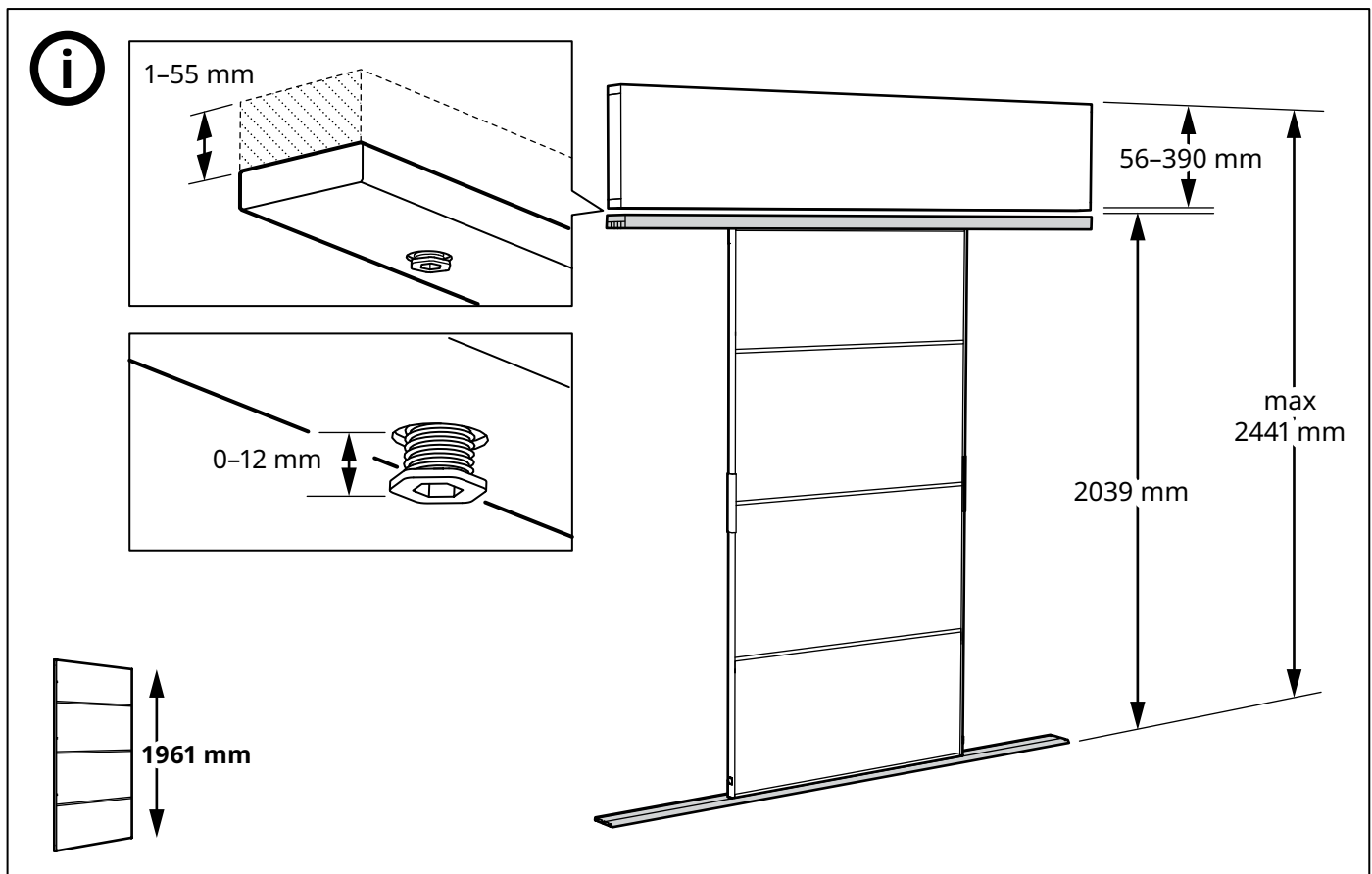
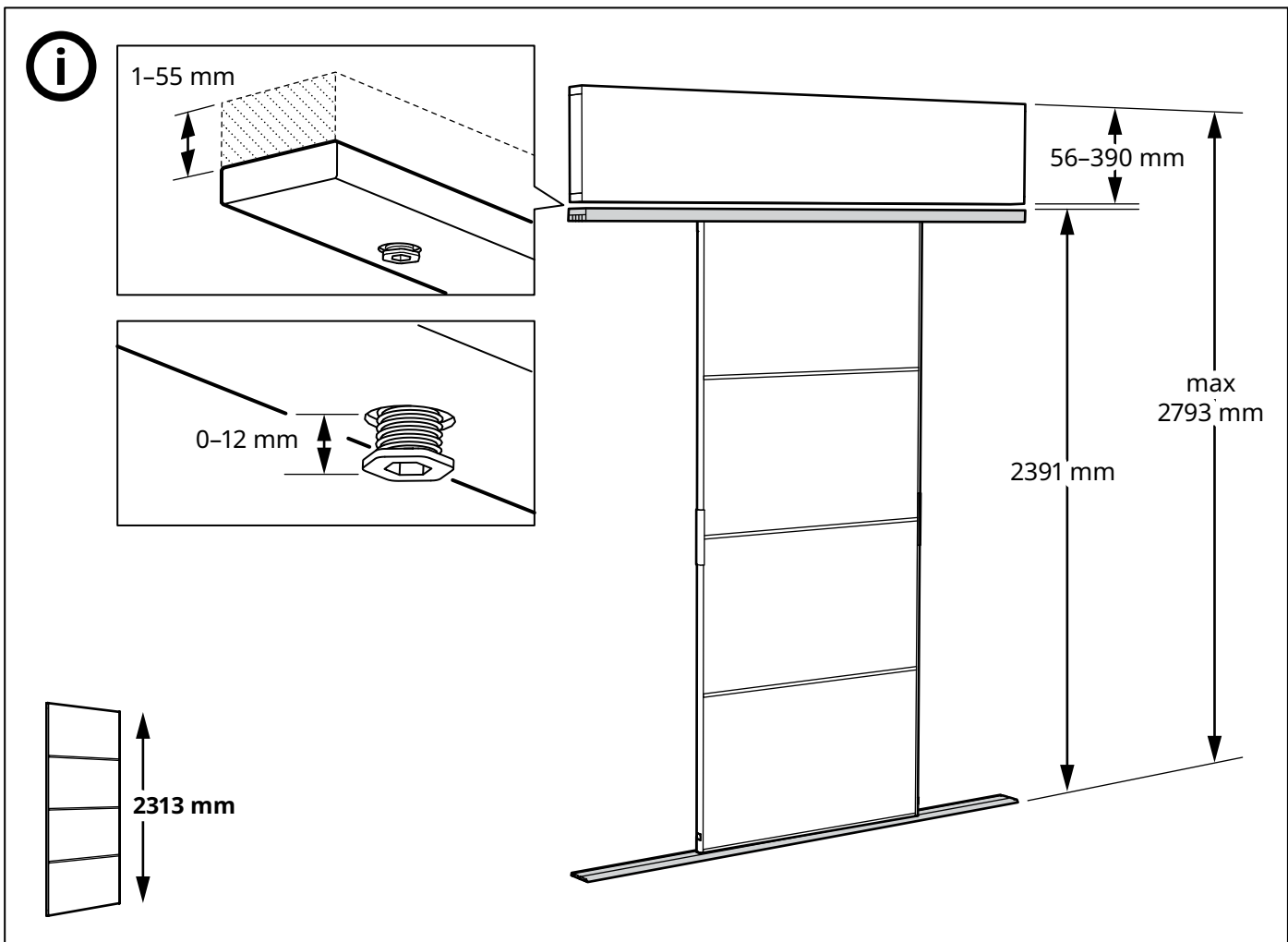



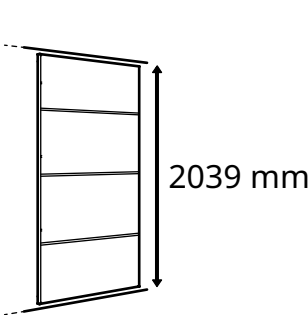
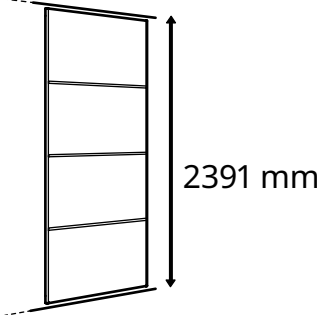
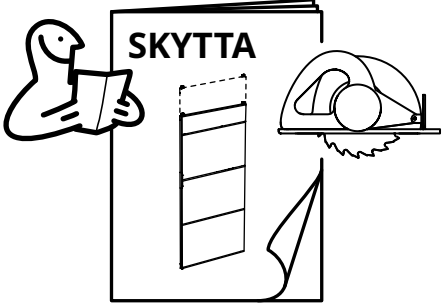

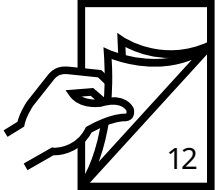
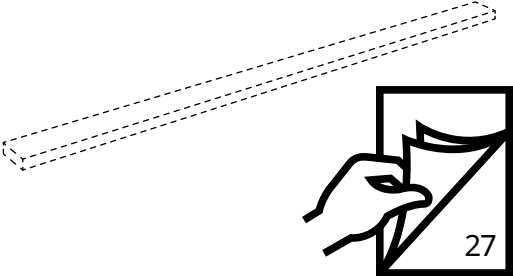
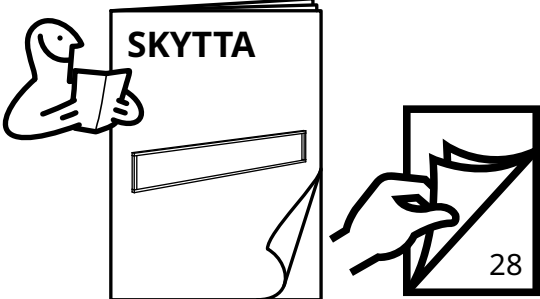
	 <p>2039 mm</p>	 <p>2391 mm</p>	
Y1 Y2 Y3	<p>1500 – 2038 mm</p>	<p>2108 – 2390 mm</p>	  <p>www.IKEA.com</p>
	<p>2039 – 2051 mm (2039 – (2039+12))</p>	<p>2391 – 2403 mm (2391 – (2391+12))</p>	
	<p>2052 – 2106 mm (2039+12+1) – (2039+12+55)</p>	<p>2404 – 2458 mm (2391+12+1) – (2391+12+55)</p>	
	<p>2107 – 2441 mm (2039+12+55+1) – (2039+12+390)</p>	<p>2459 – 2793 mm (2391+12+55+1) – (2391+12+390)</p>	

1

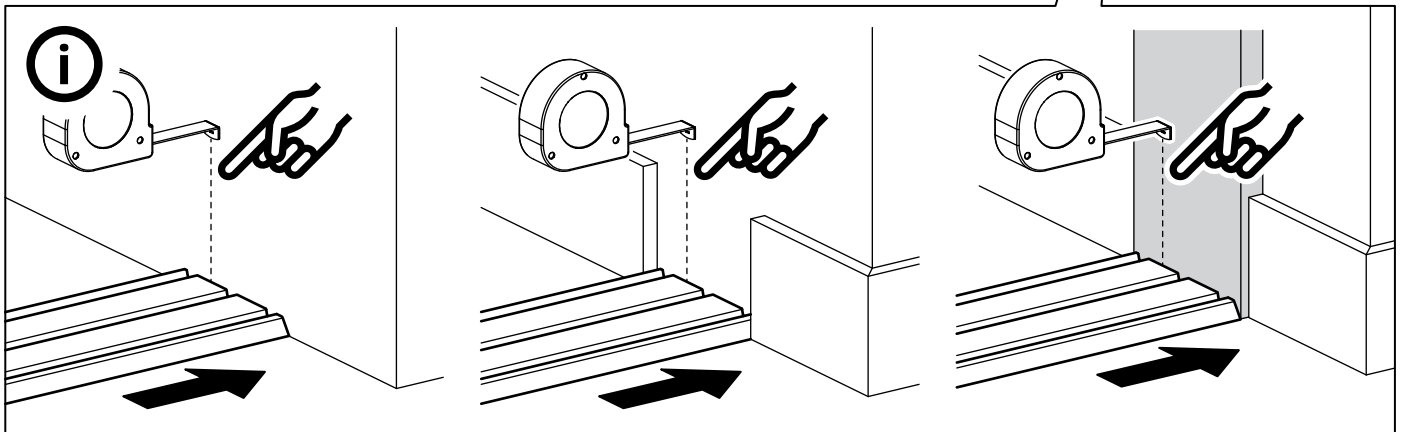
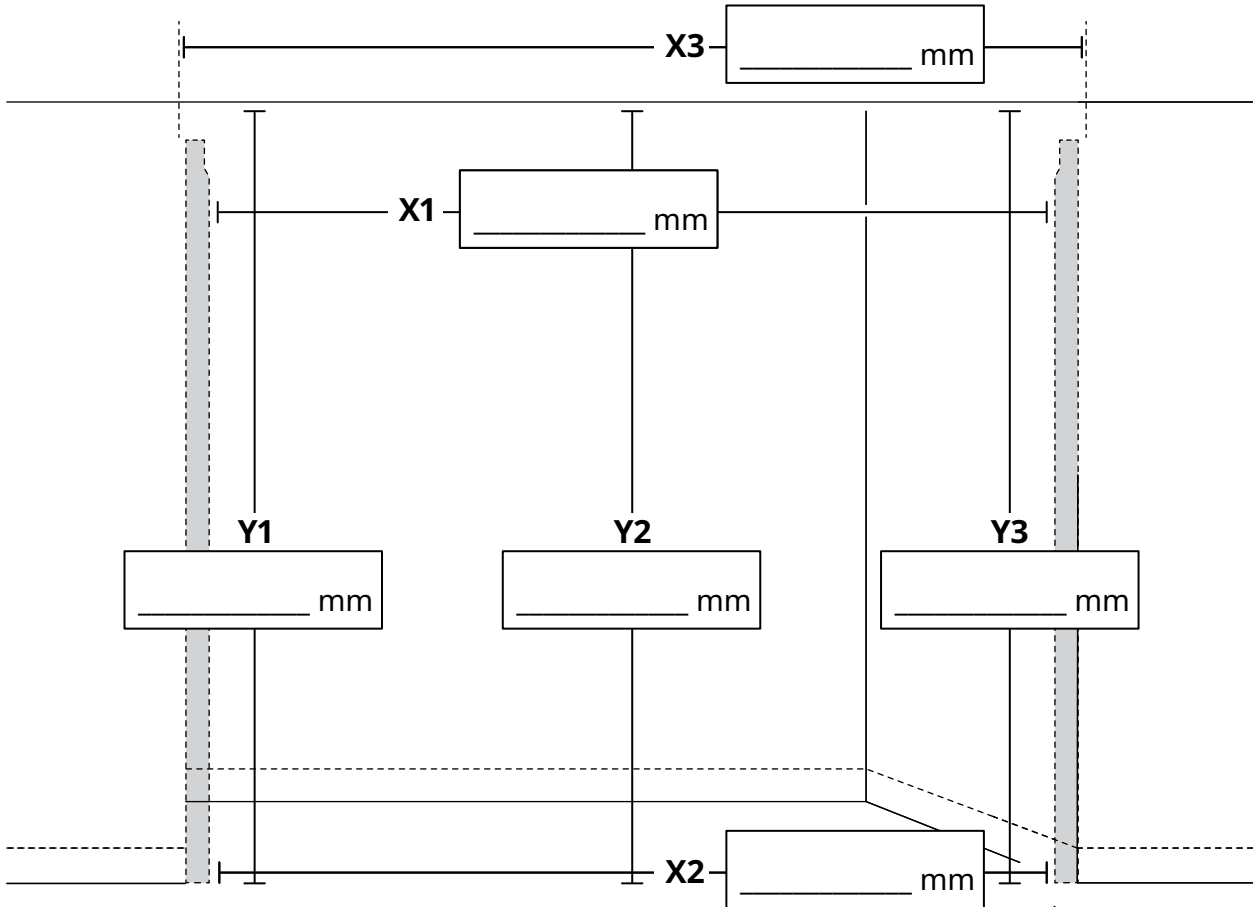
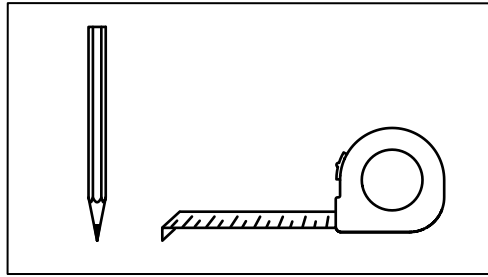

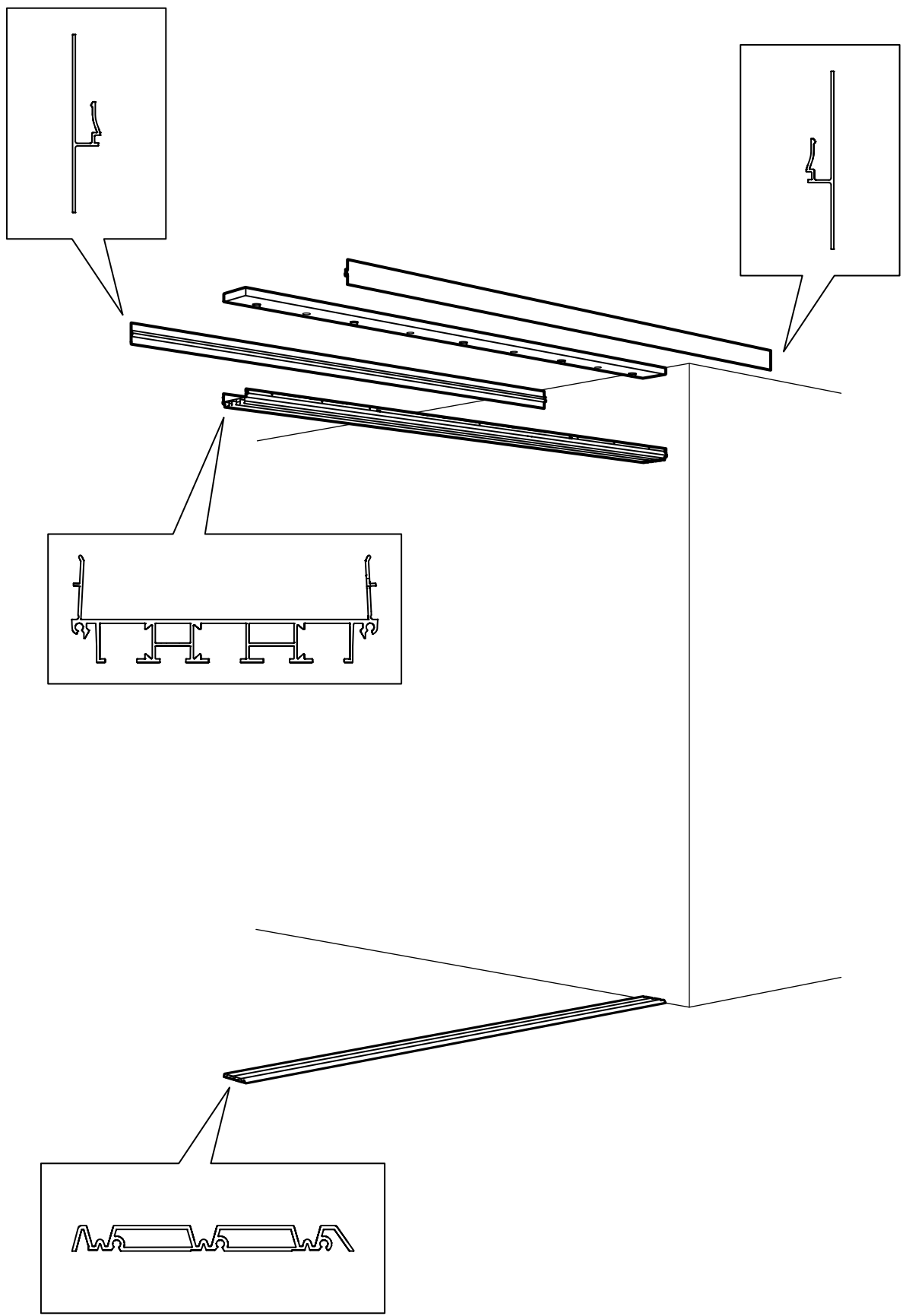

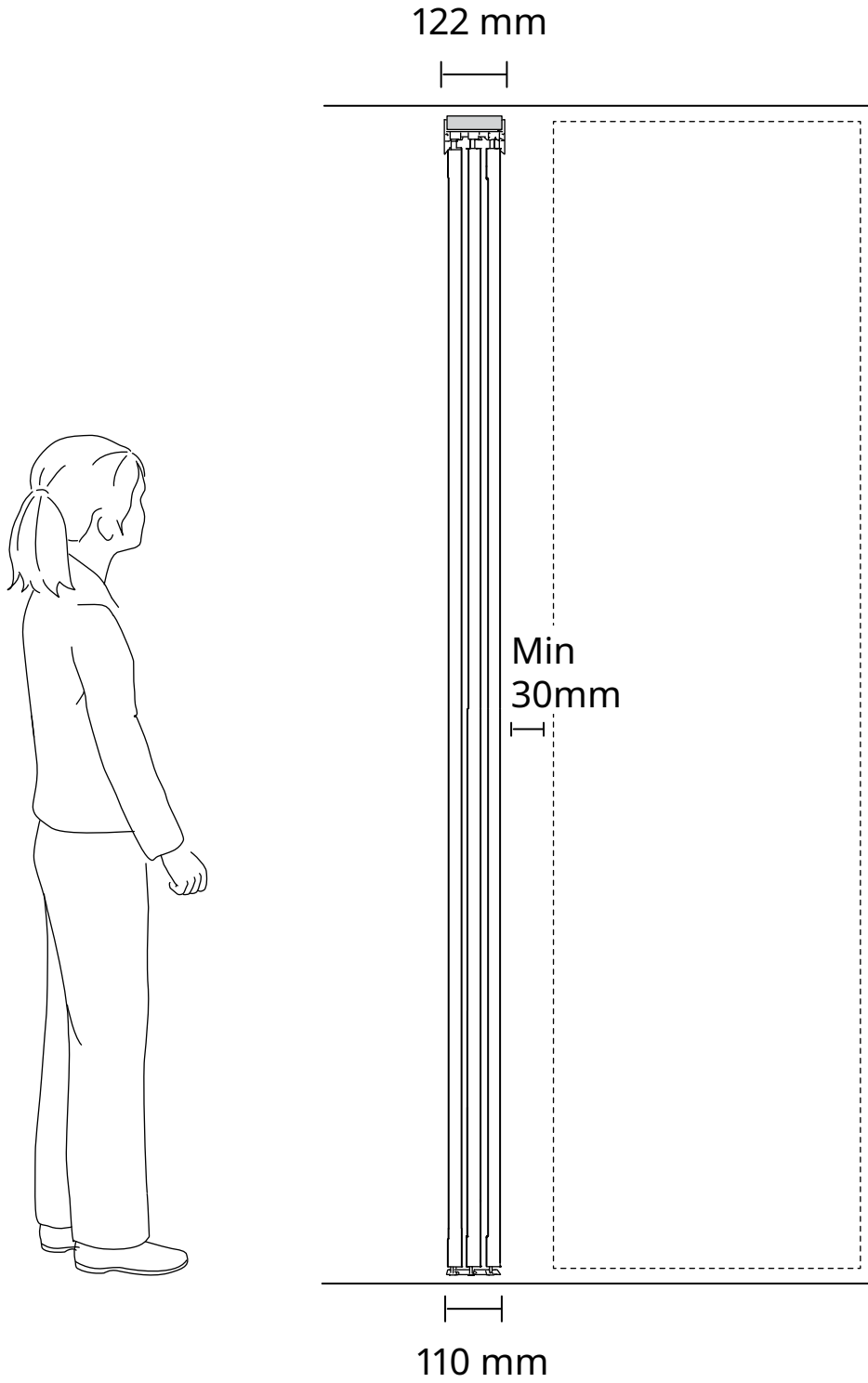

i

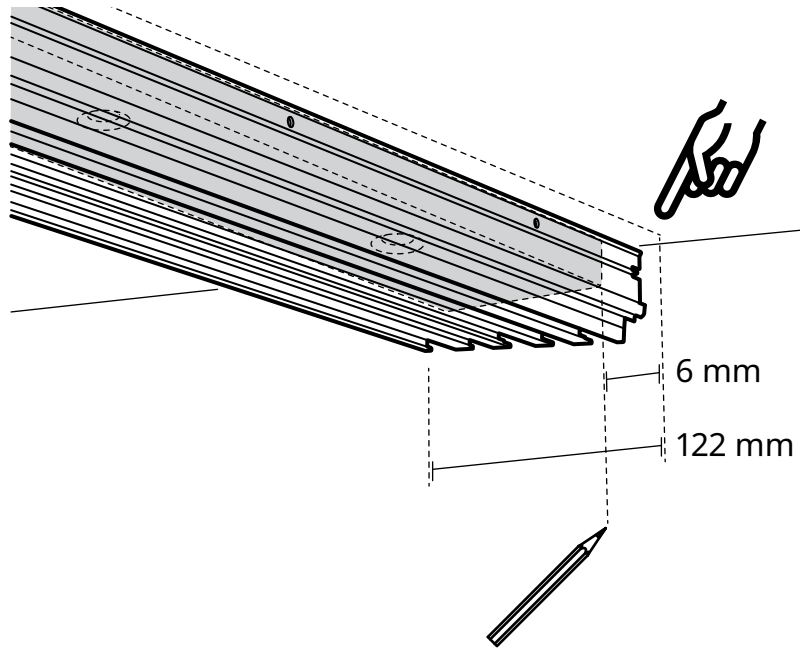

2

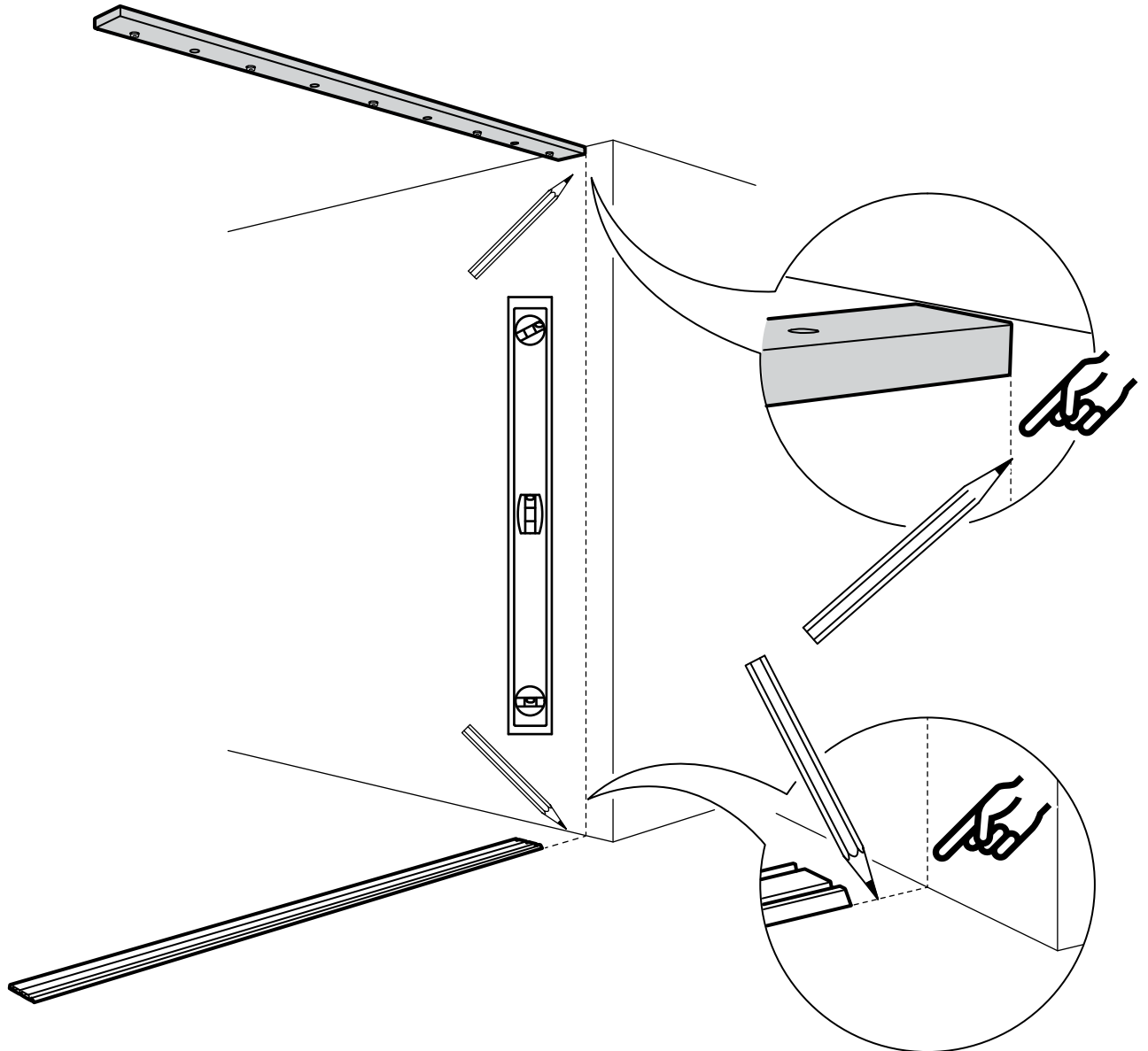

3

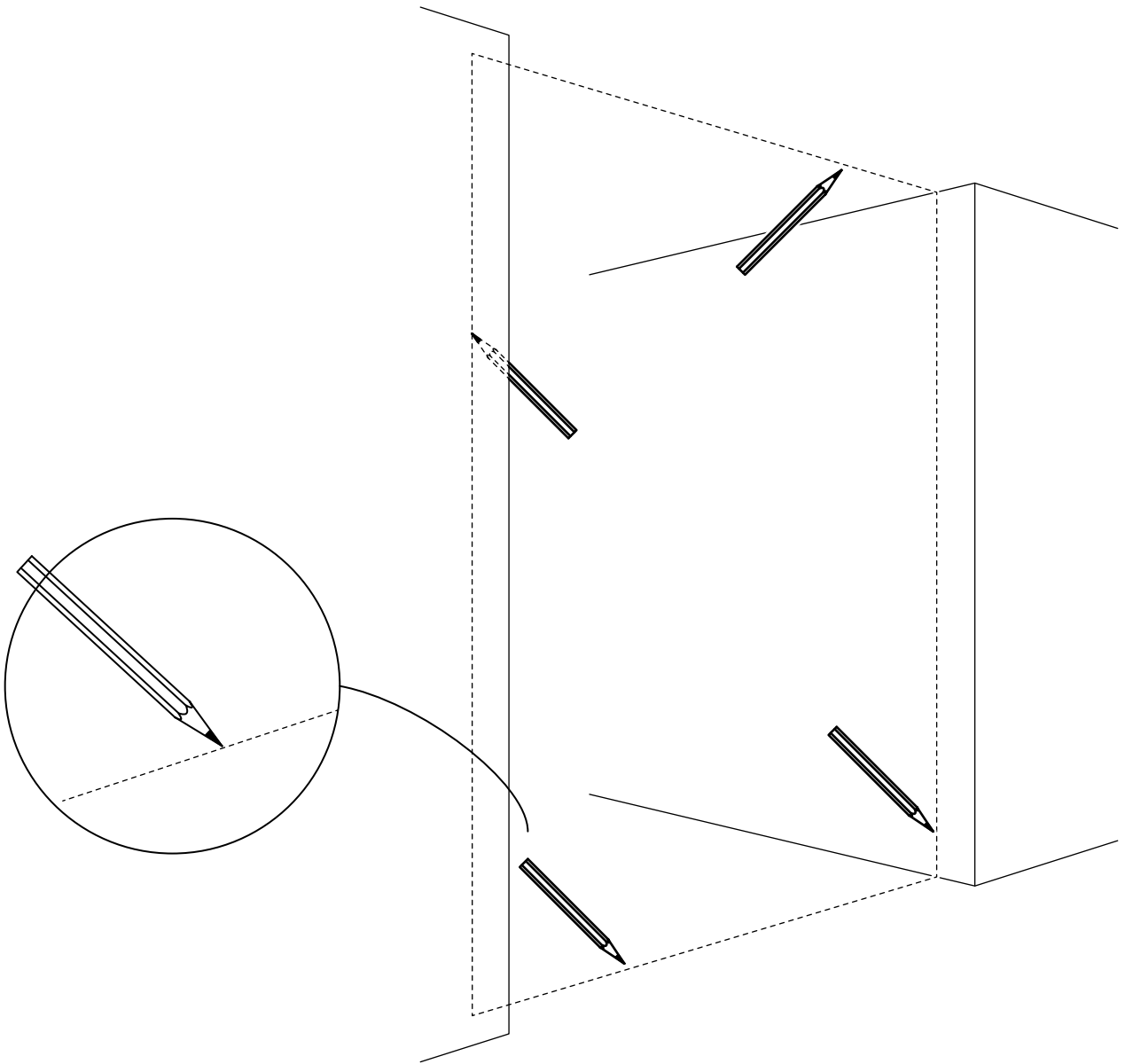

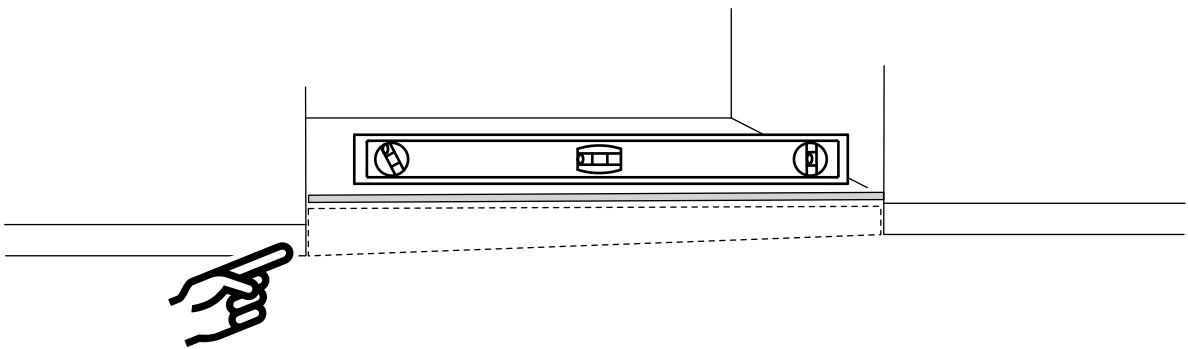
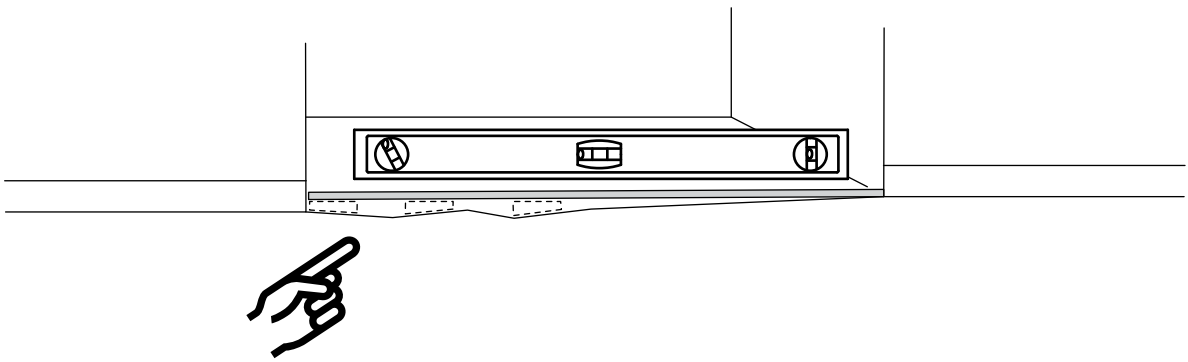
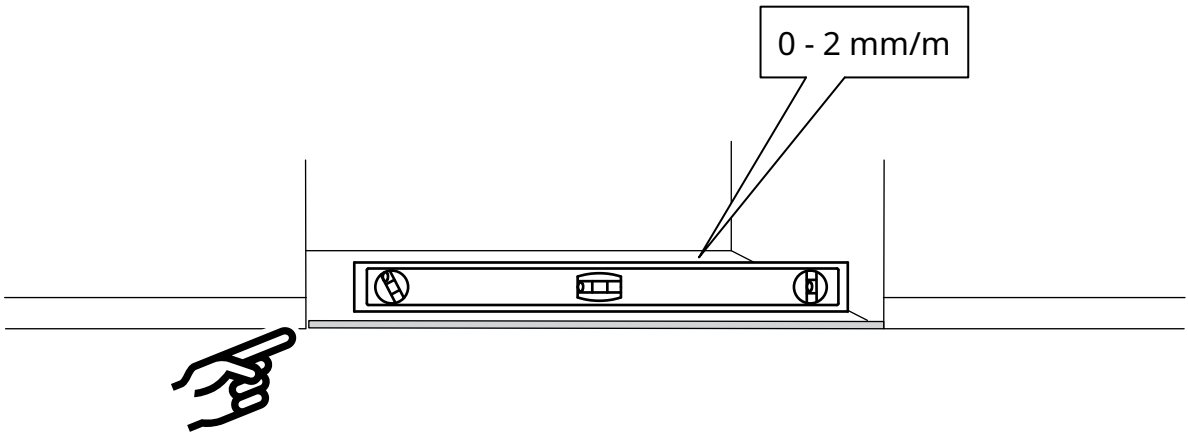

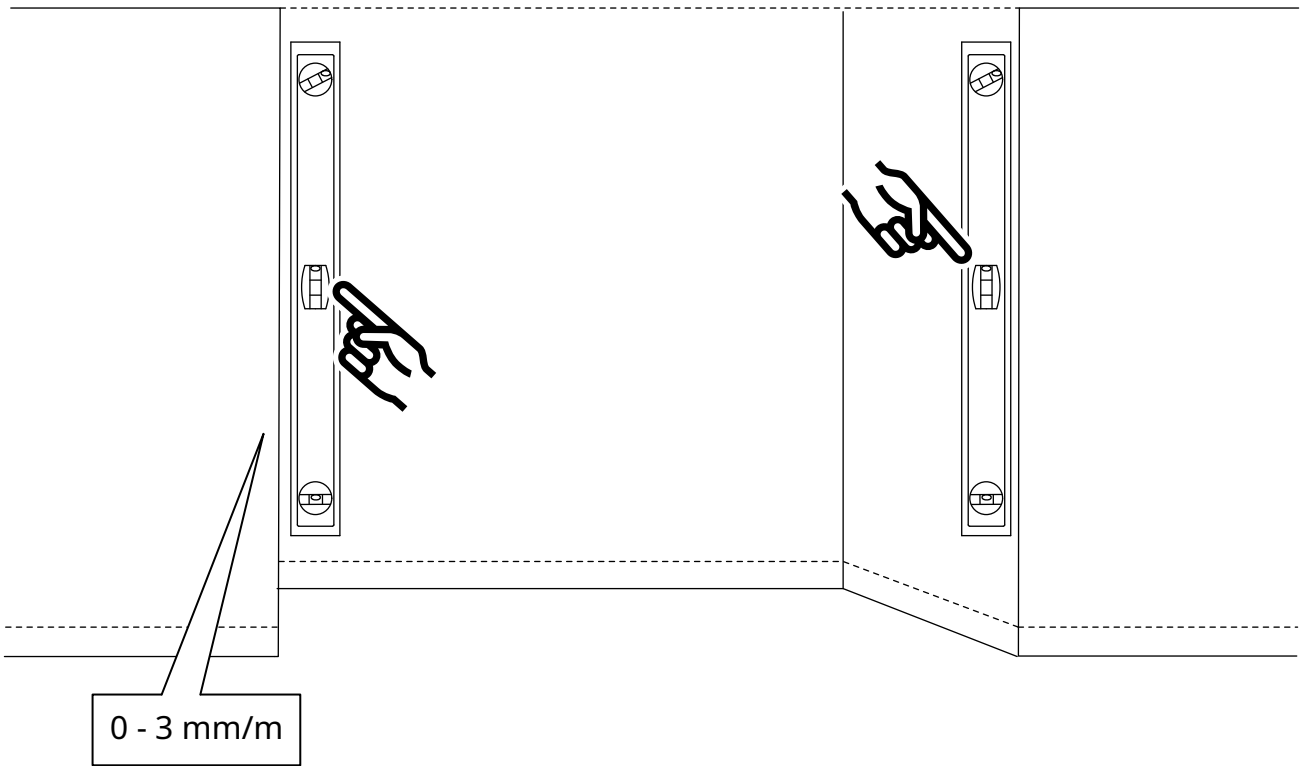

4

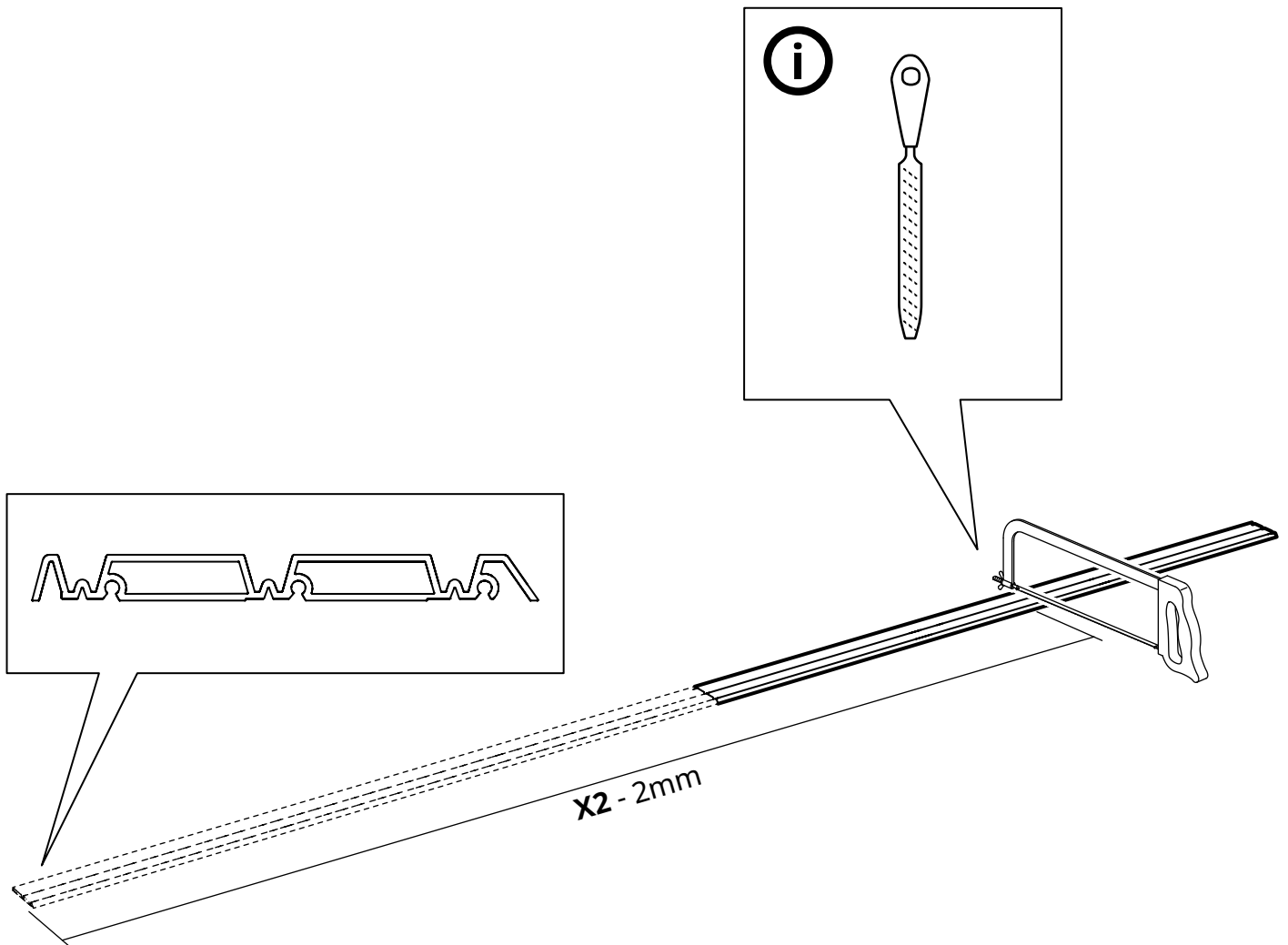
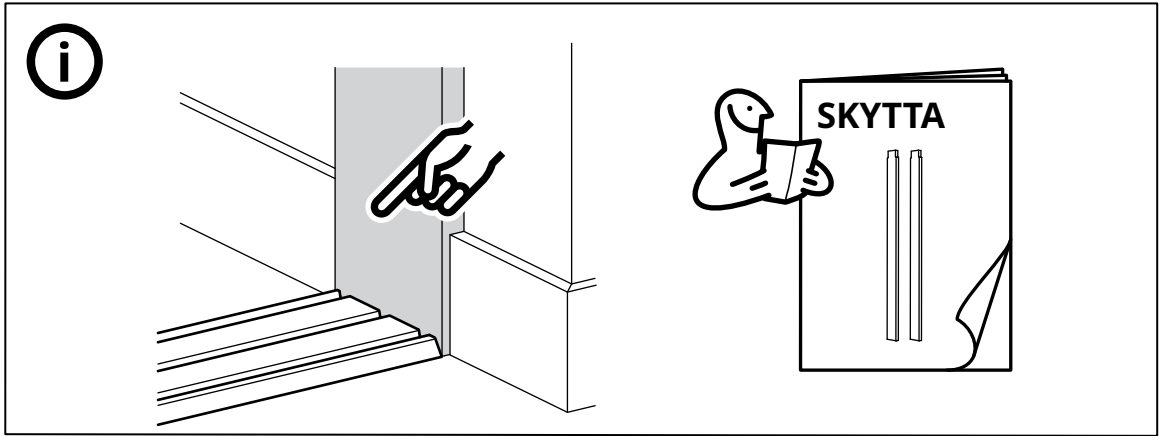

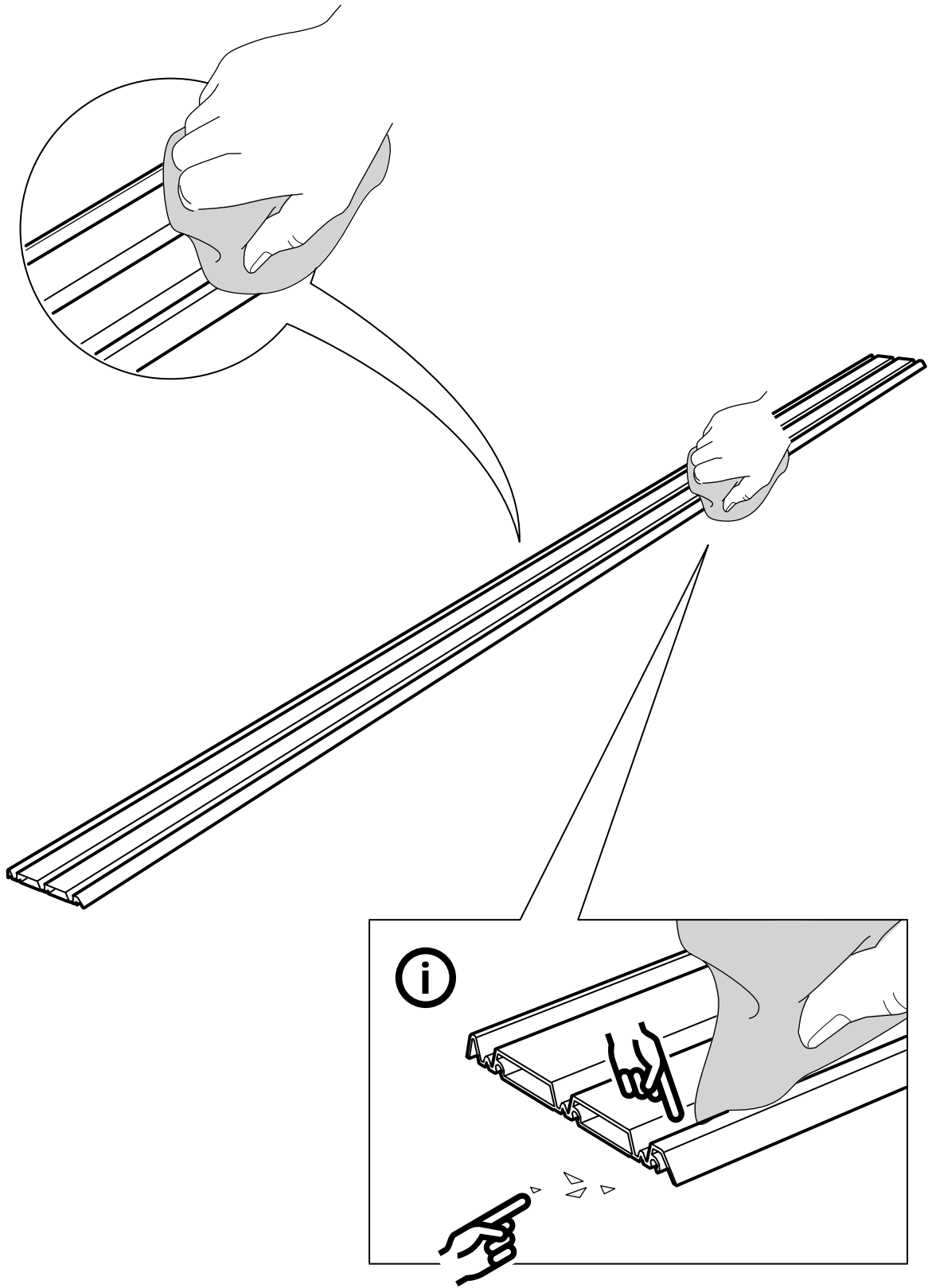

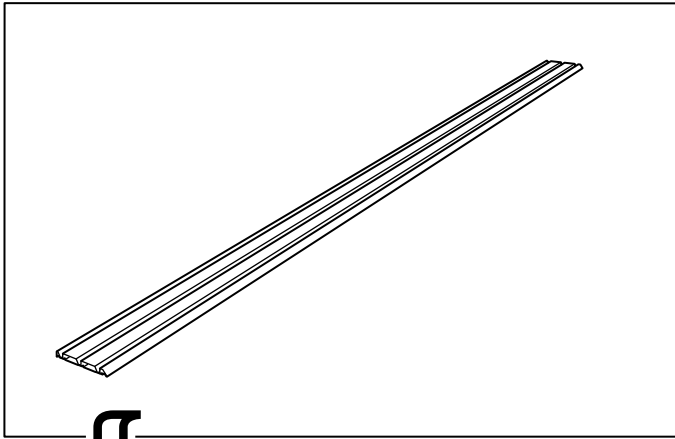

6

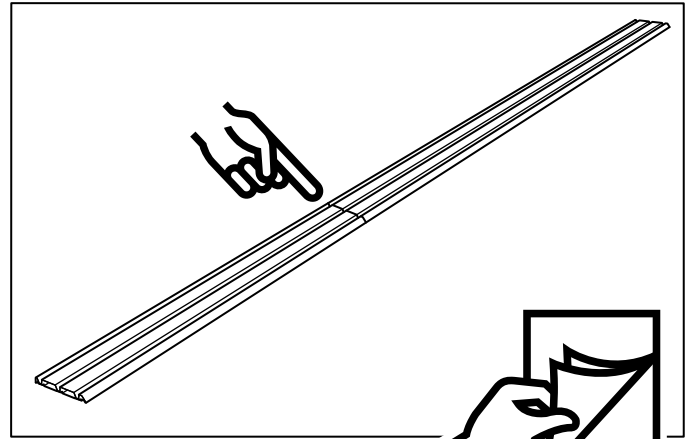
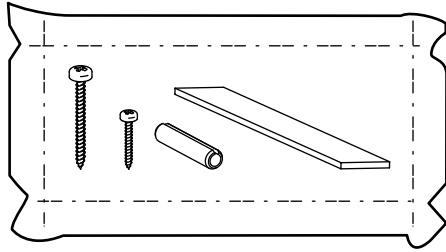

23

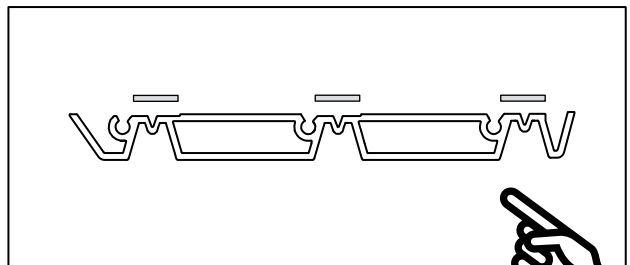
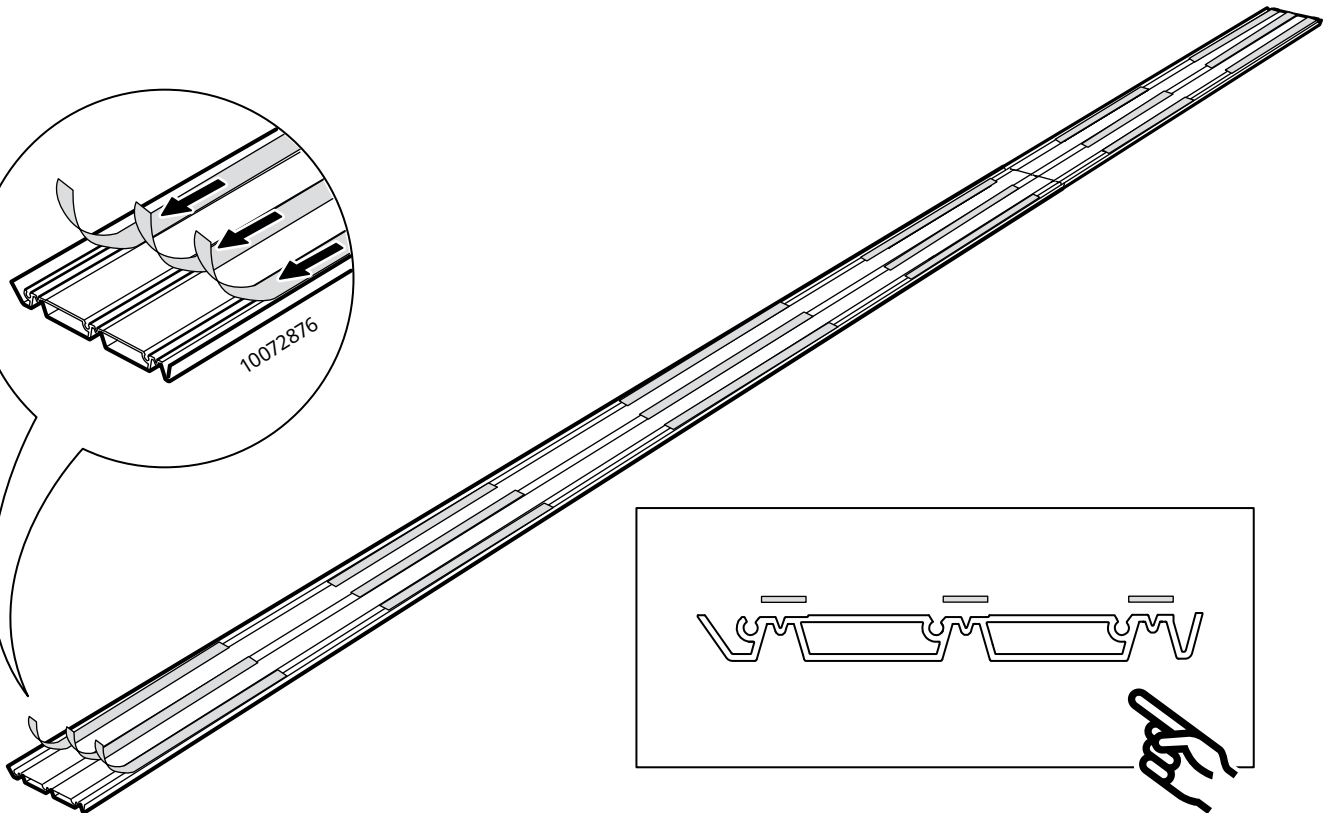
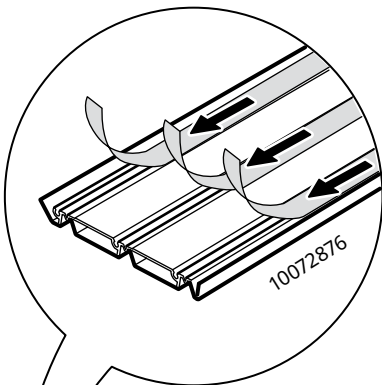

7

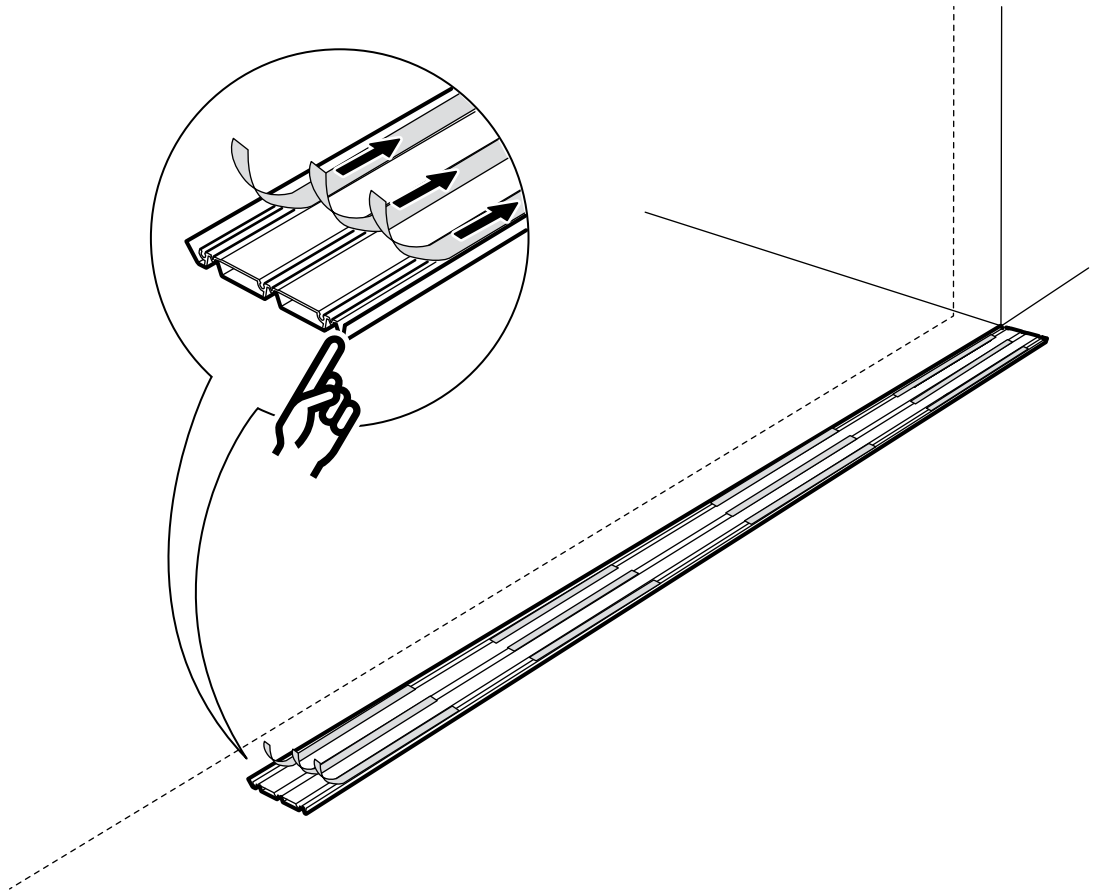

8

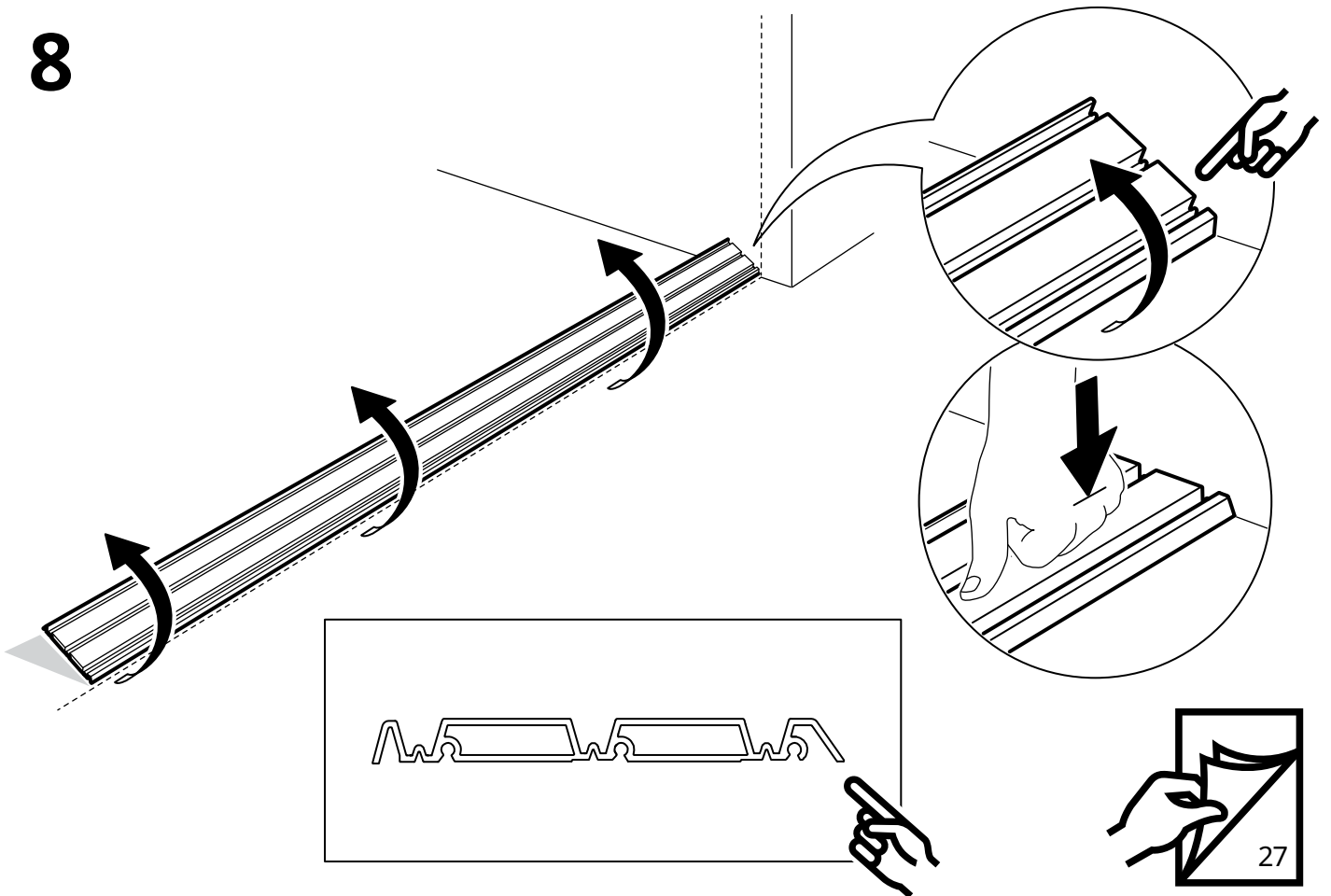

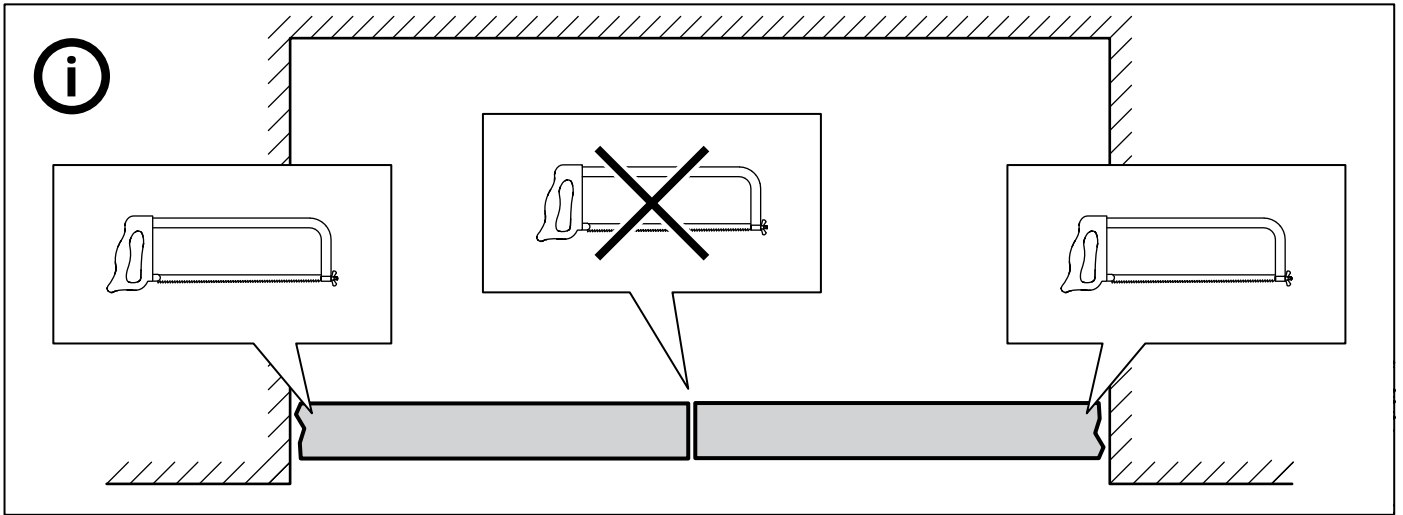
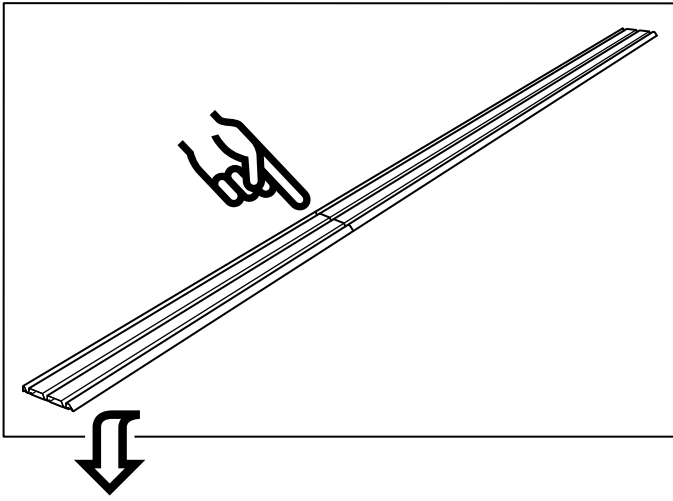

9

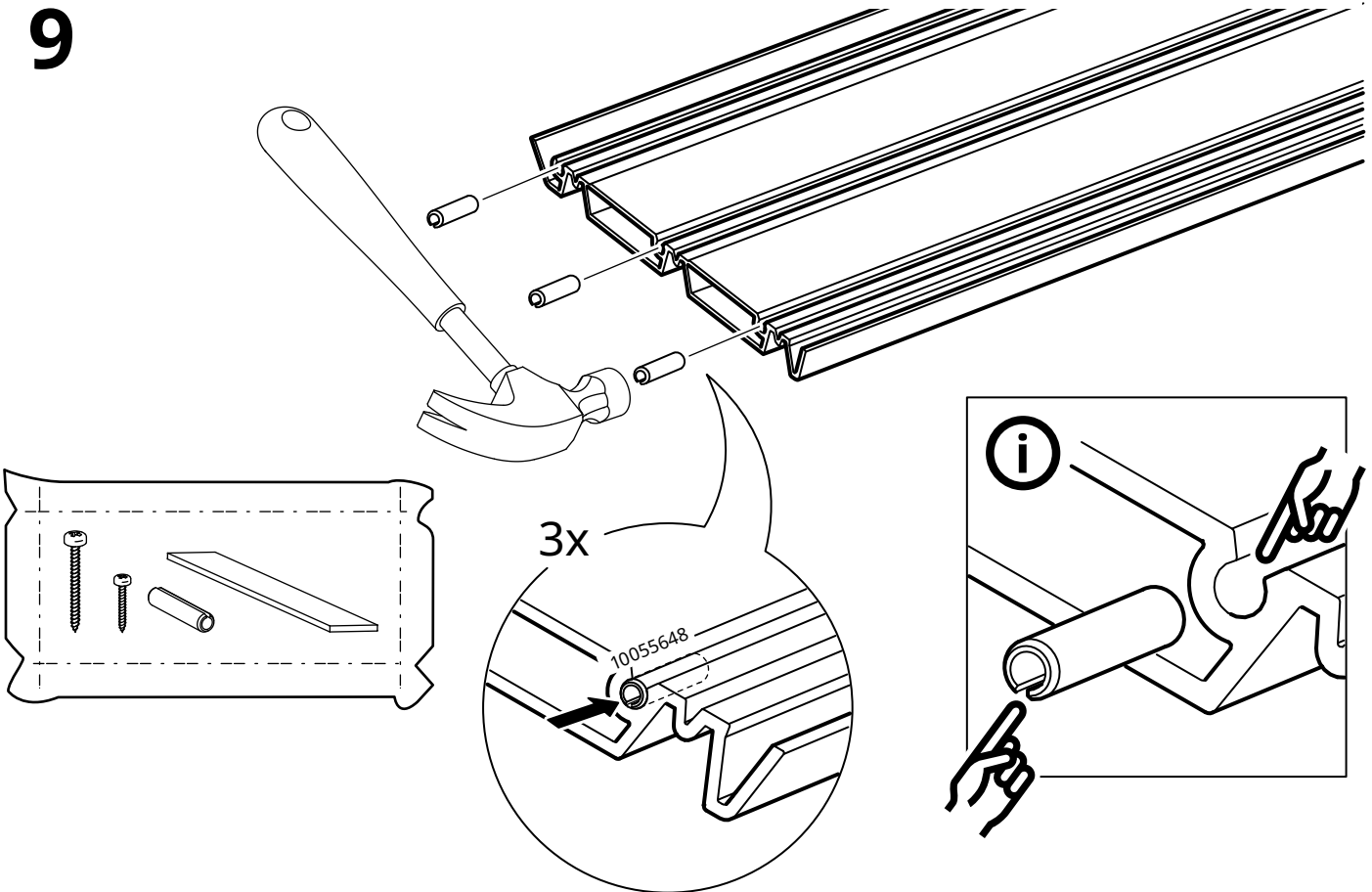

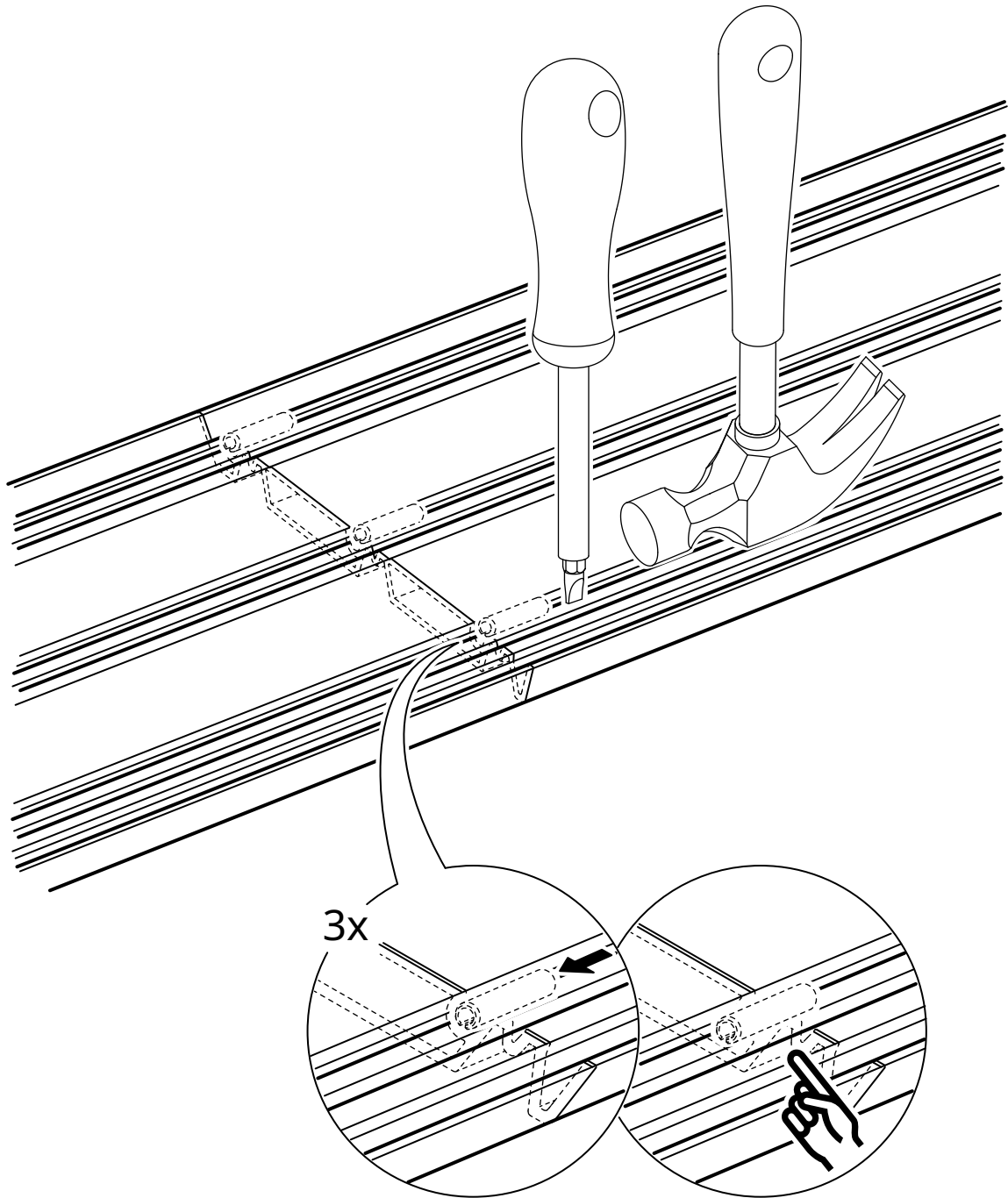

11

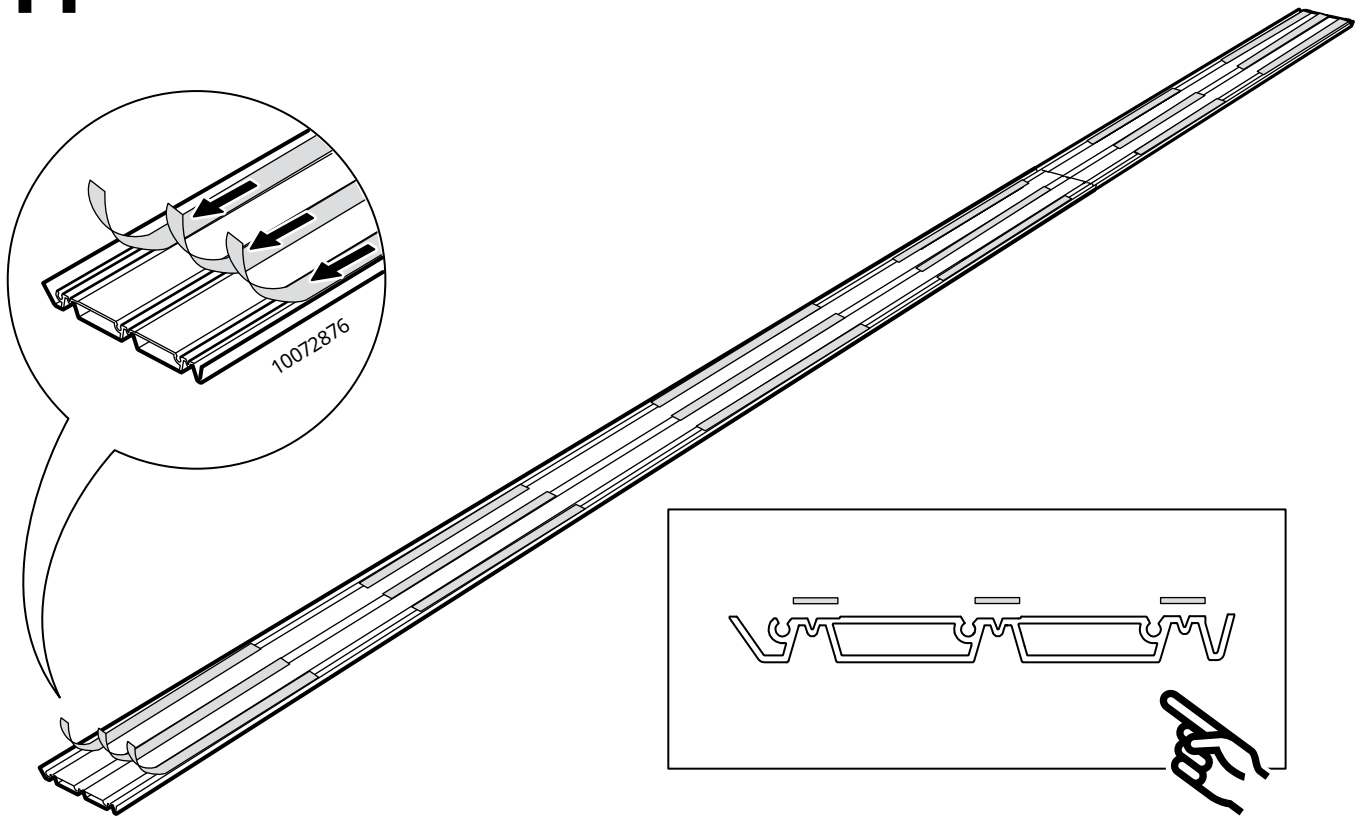

12

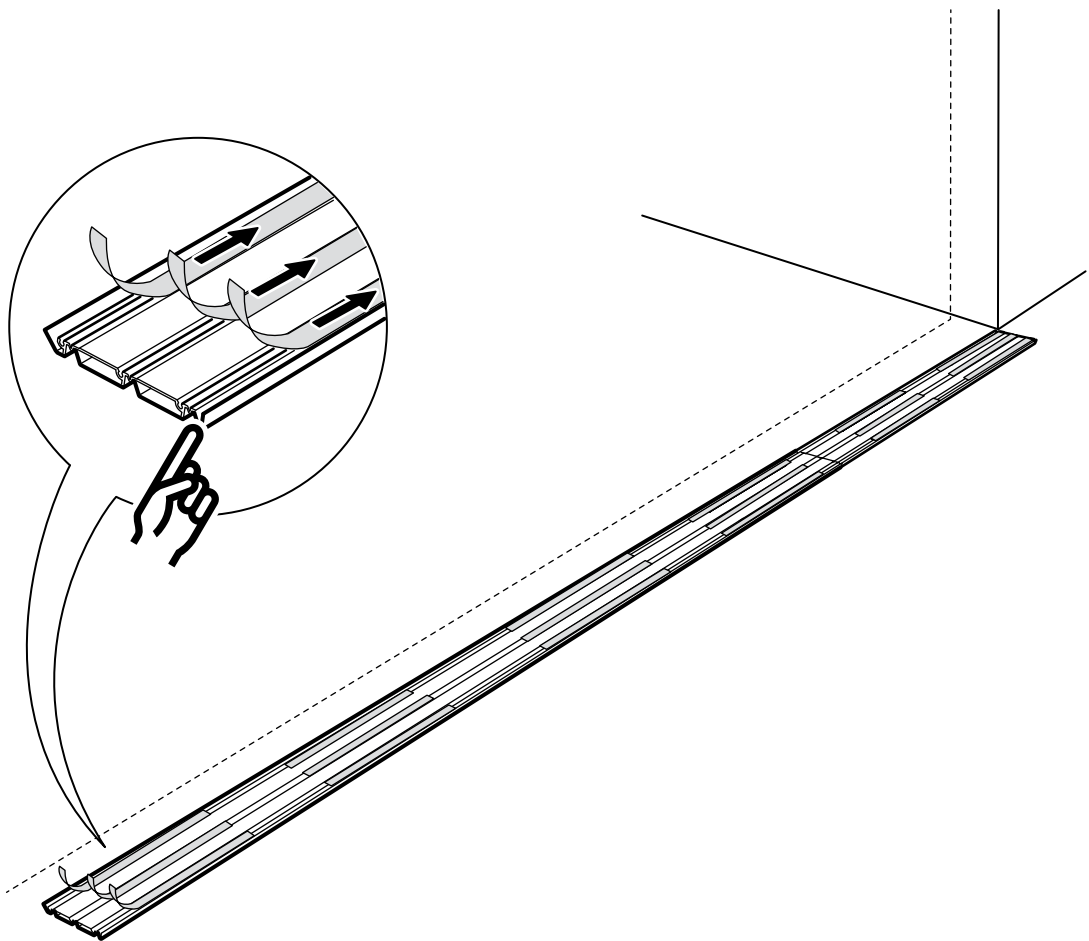

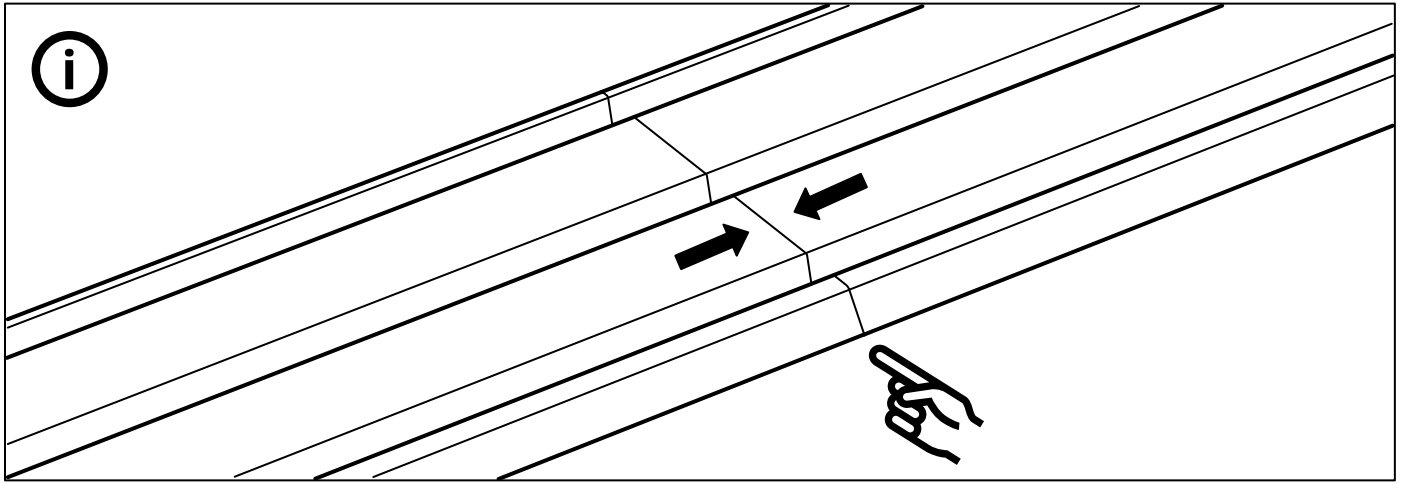

13

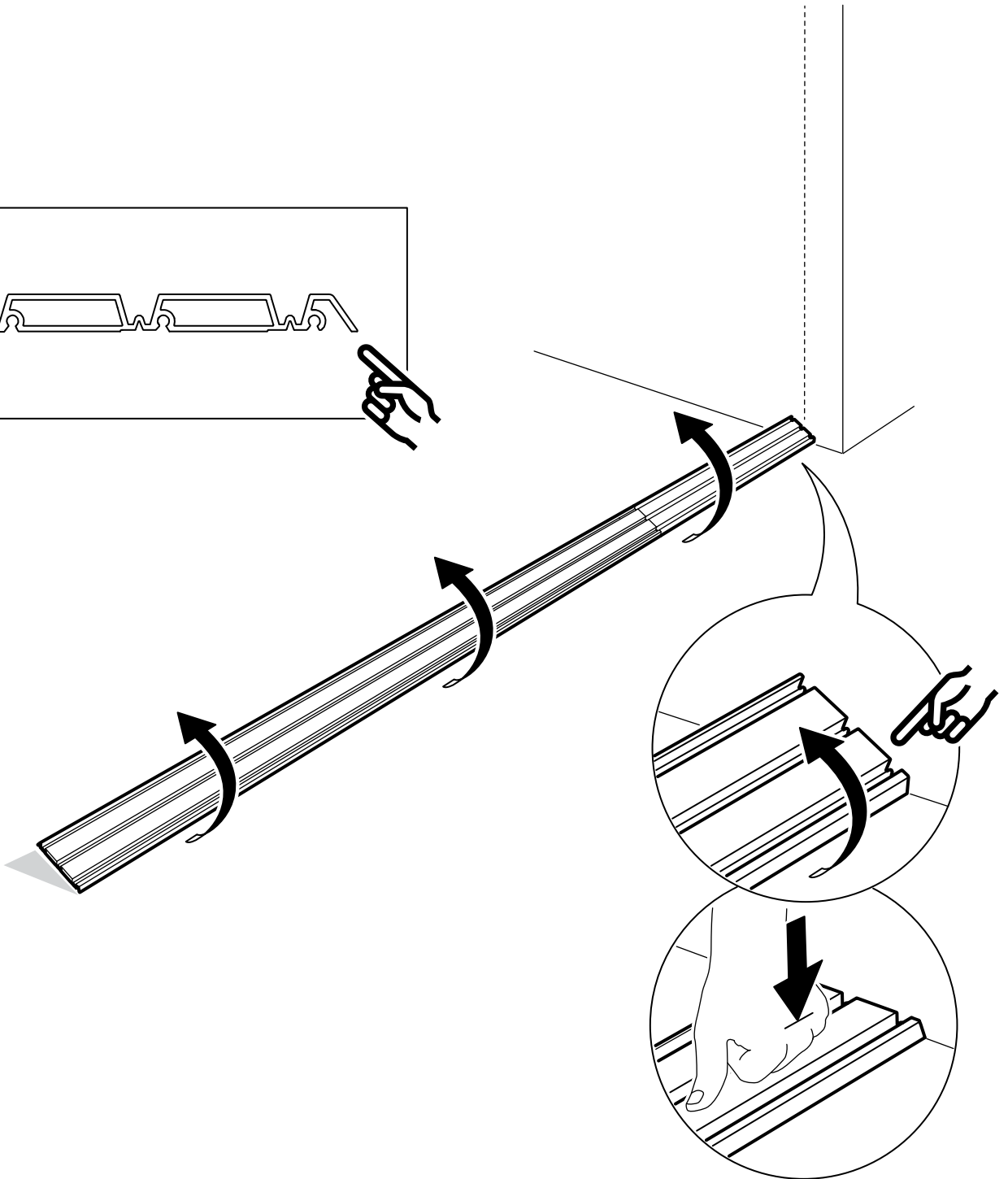
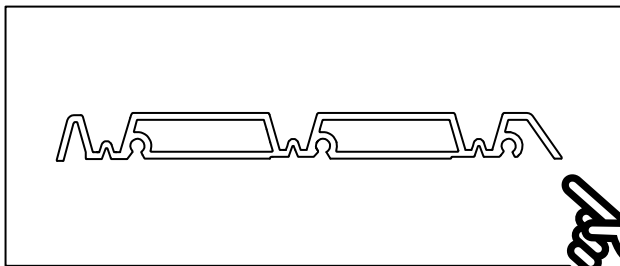

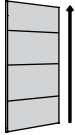

	Y
1961 mm	2039 - 2051 mm
2313 mm	2391 - 2403 mm

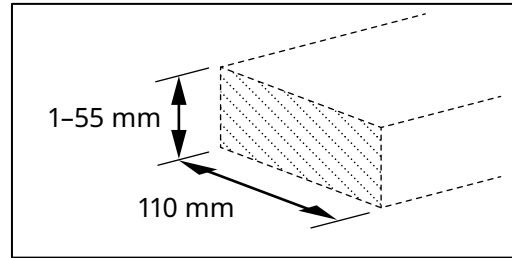

1

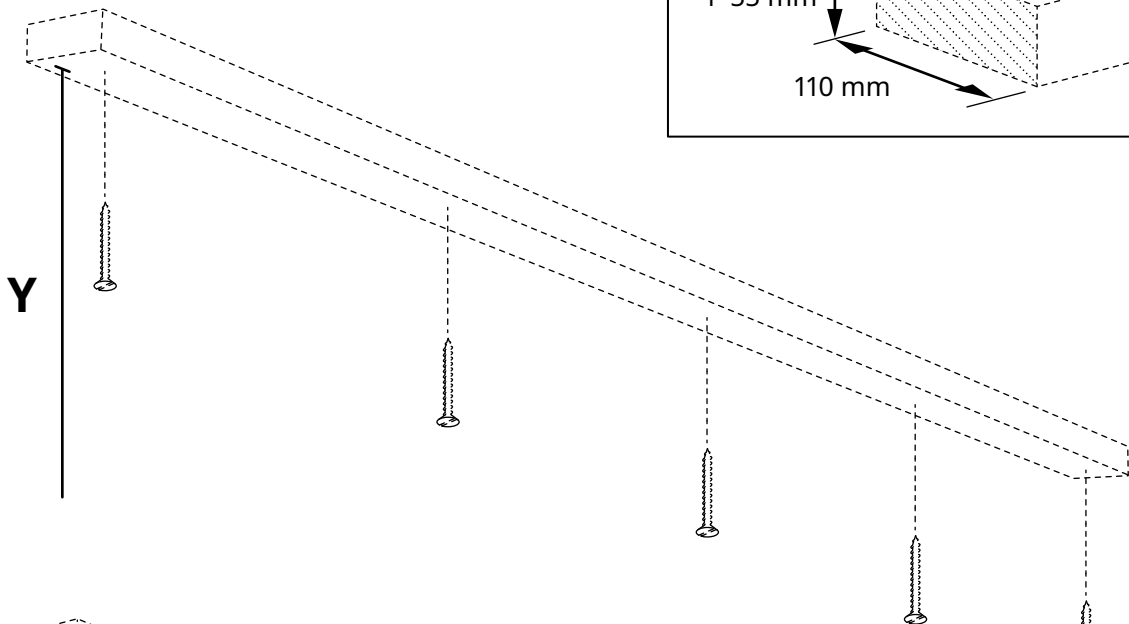

2

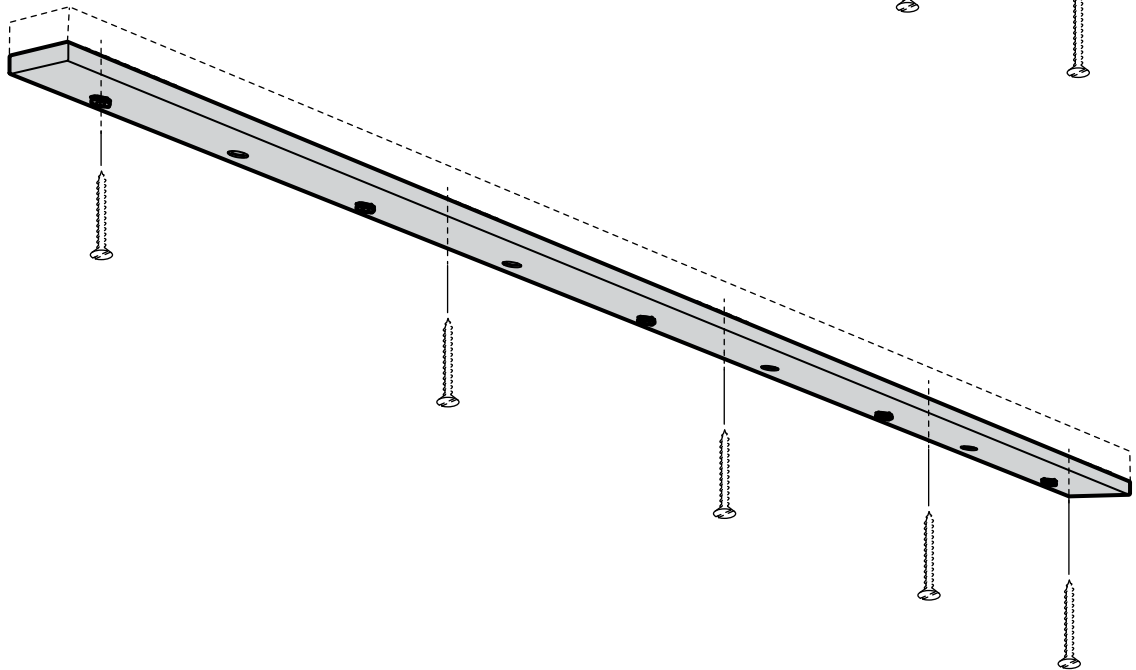

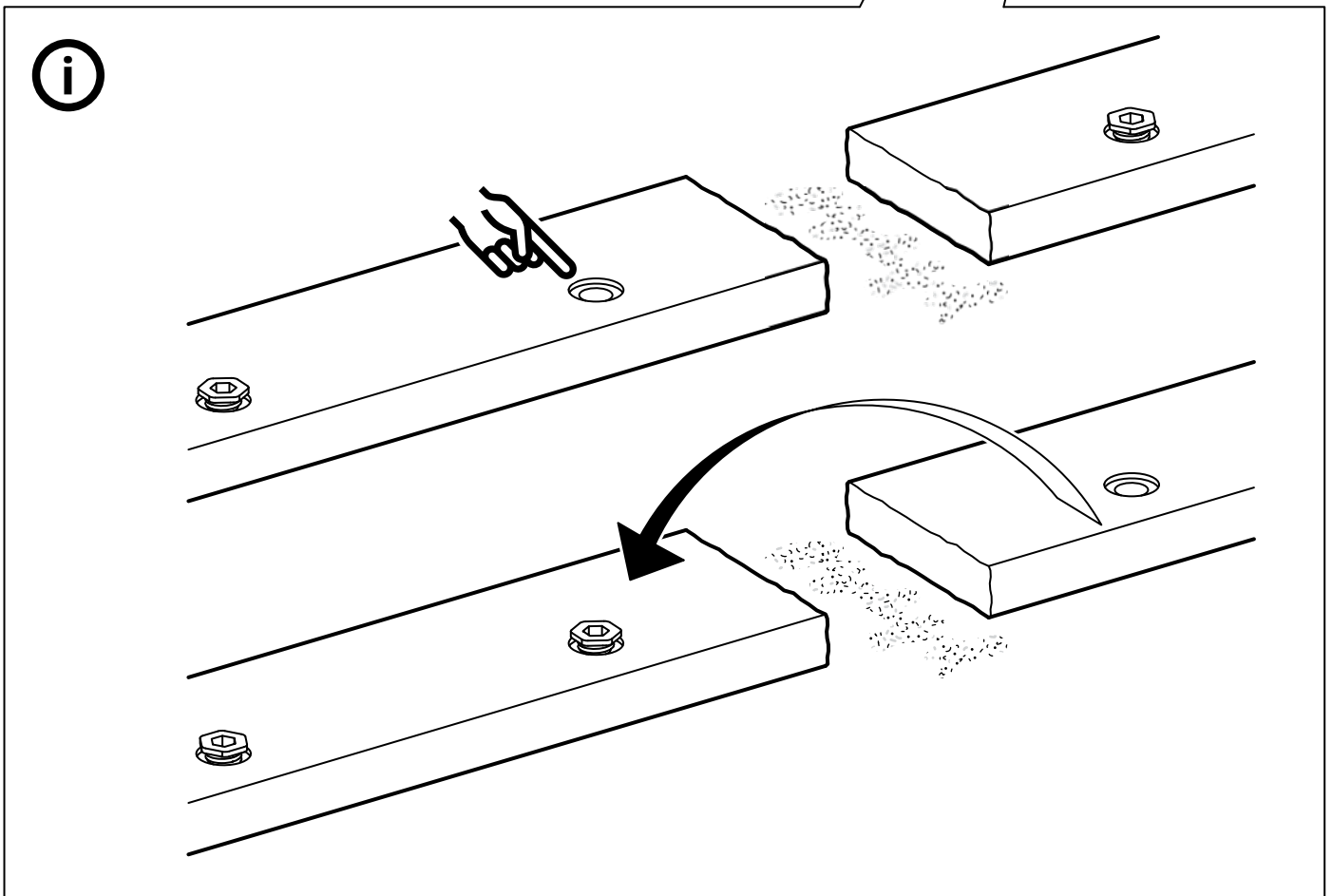
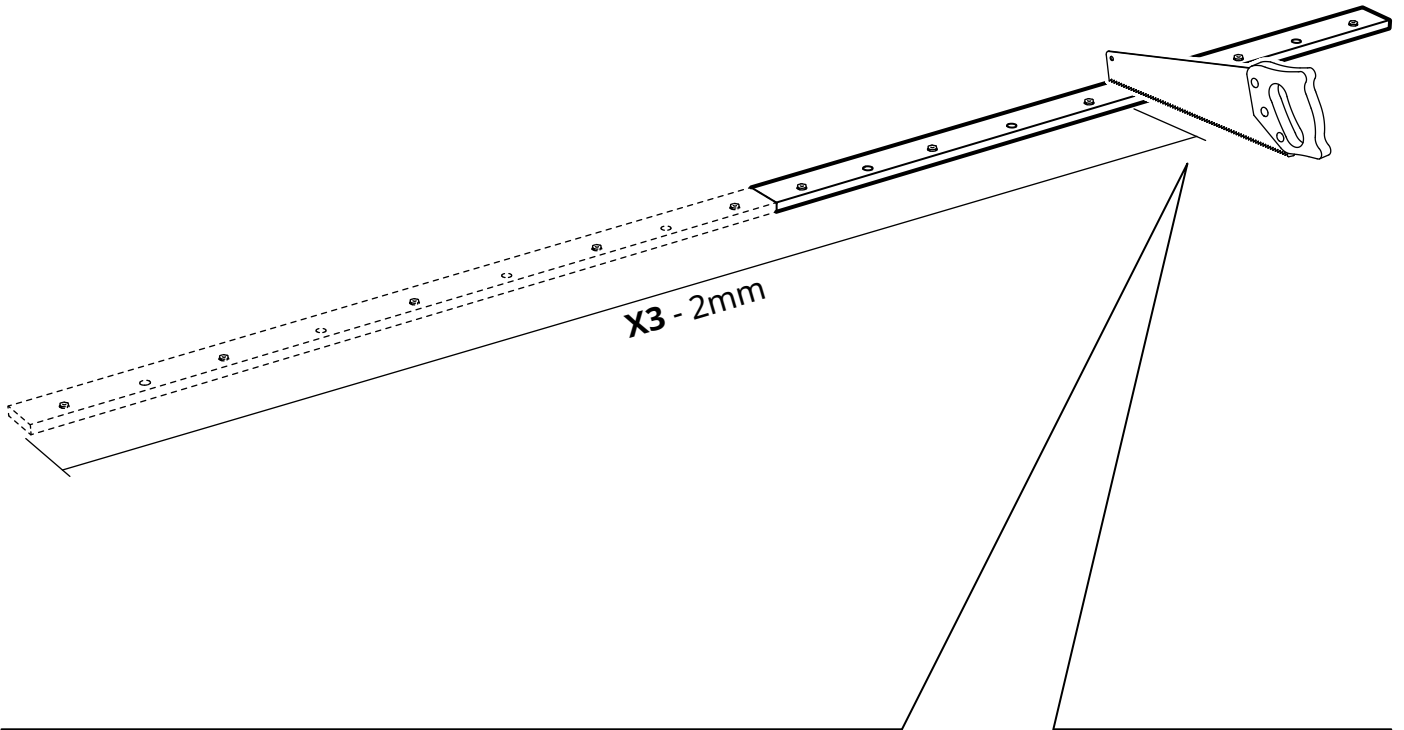

15

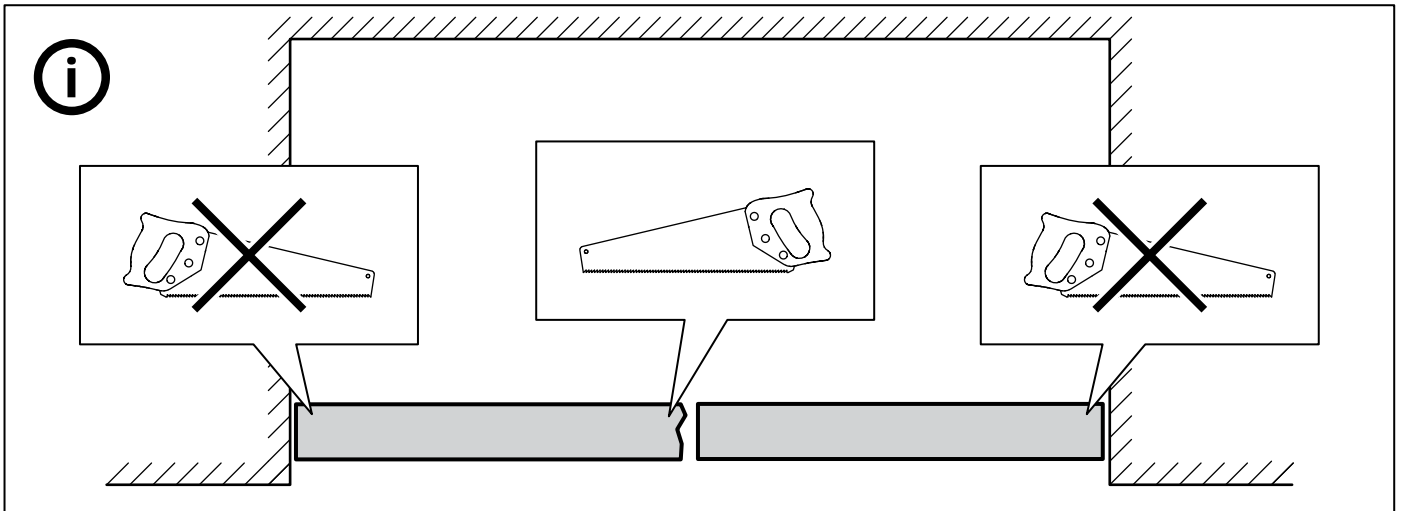
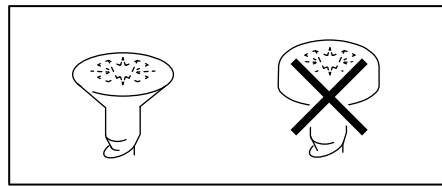
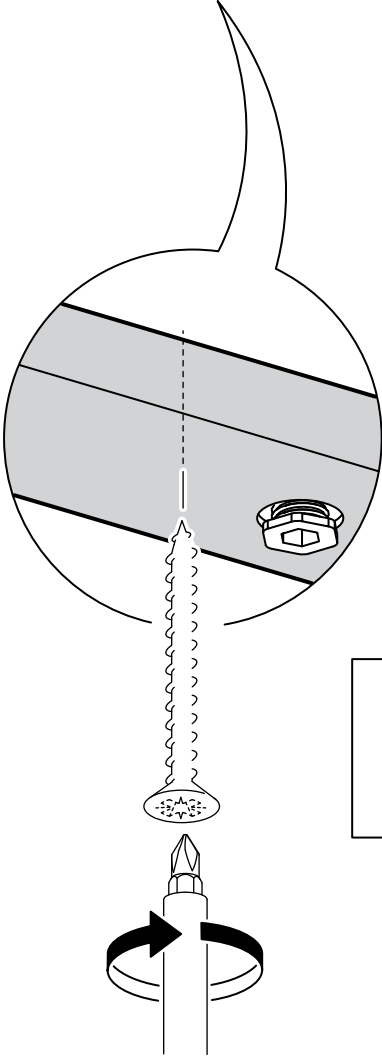
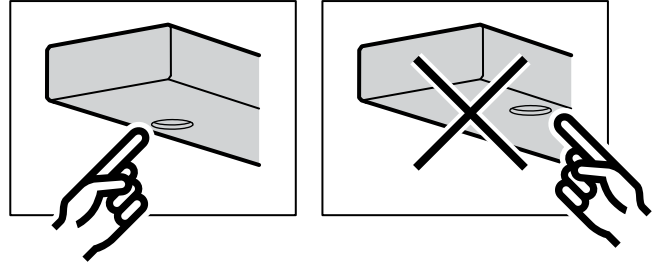

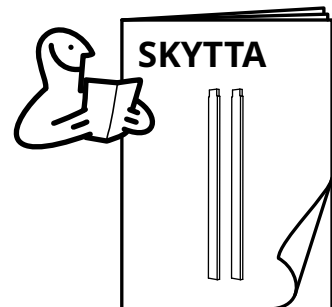
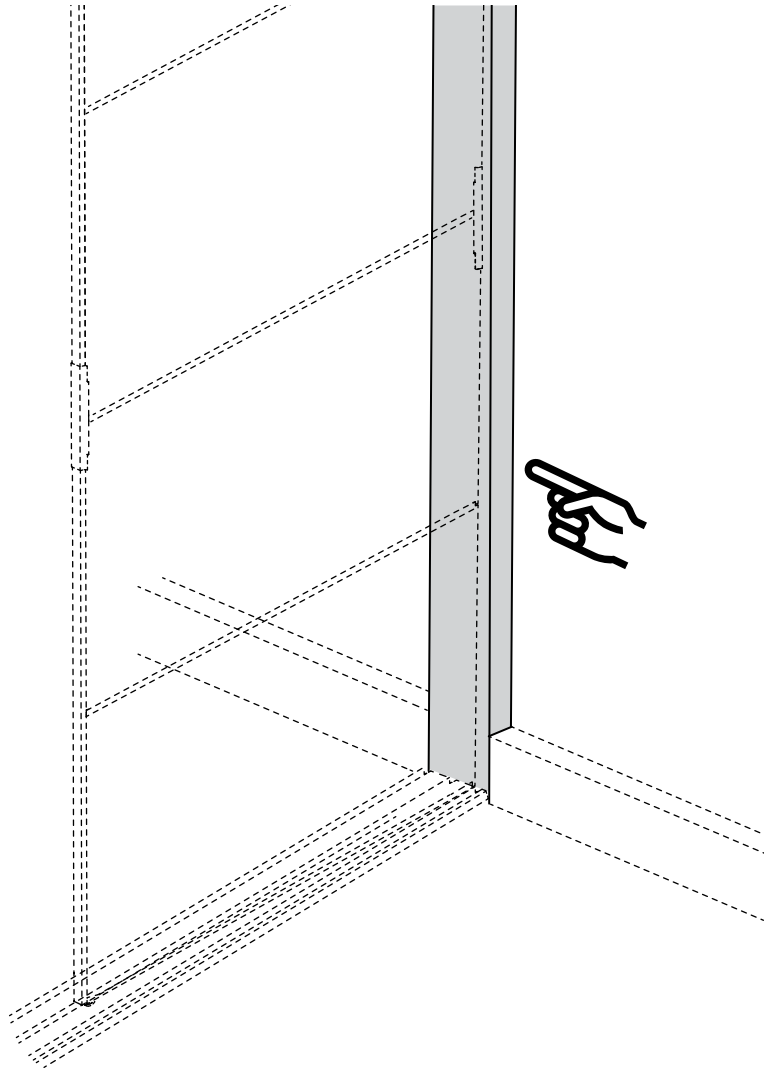

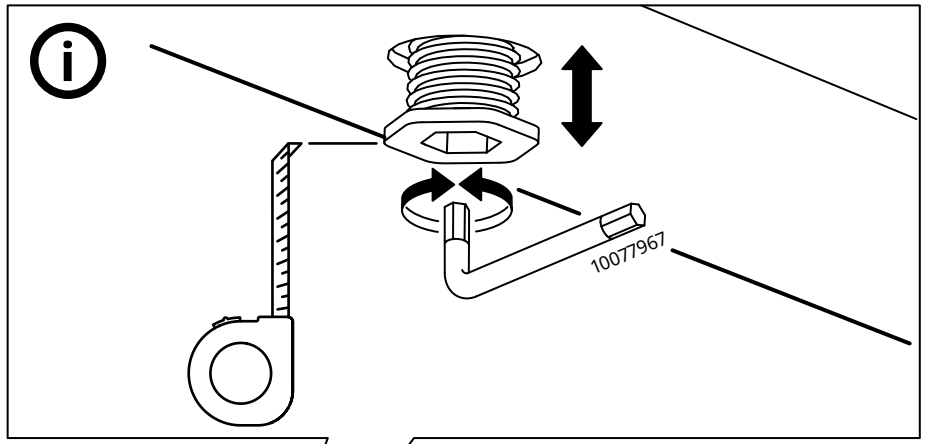
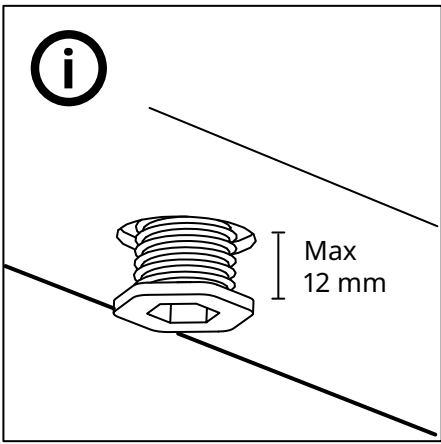

16

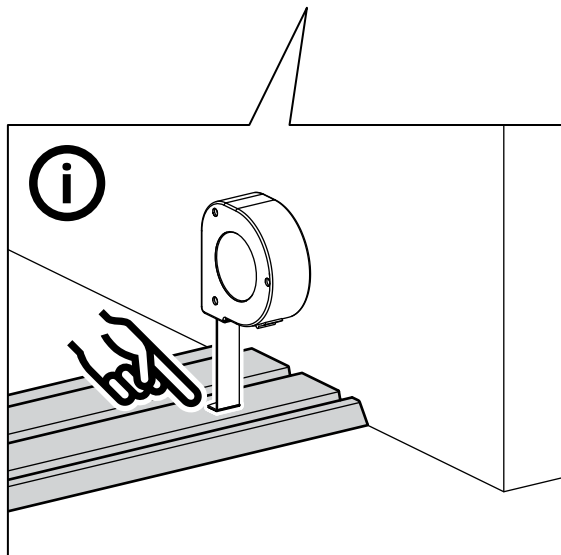
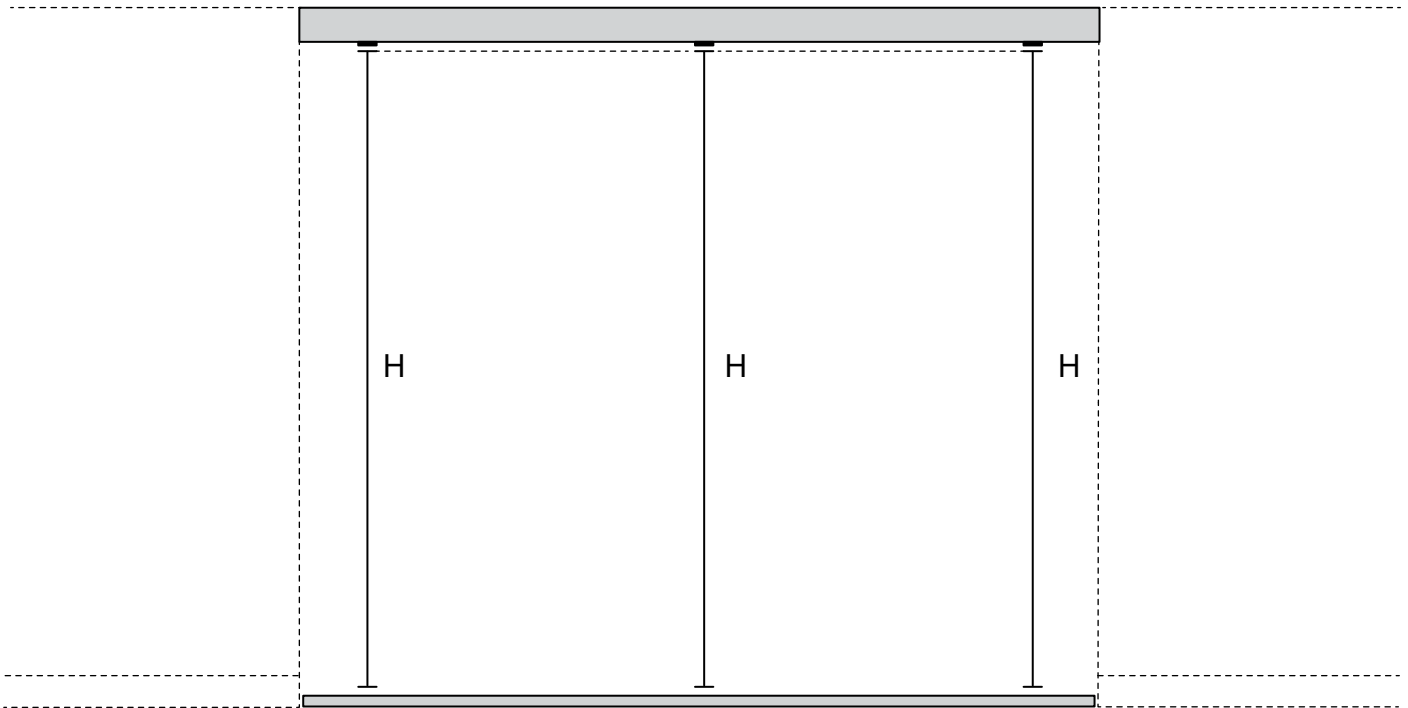

	H
1961 mm	2004 mm
2313 mm	2356 mm

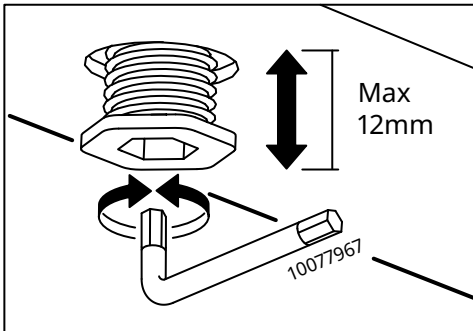
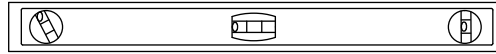
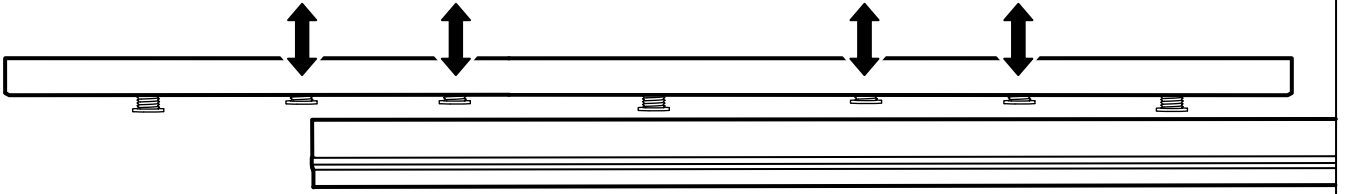

17

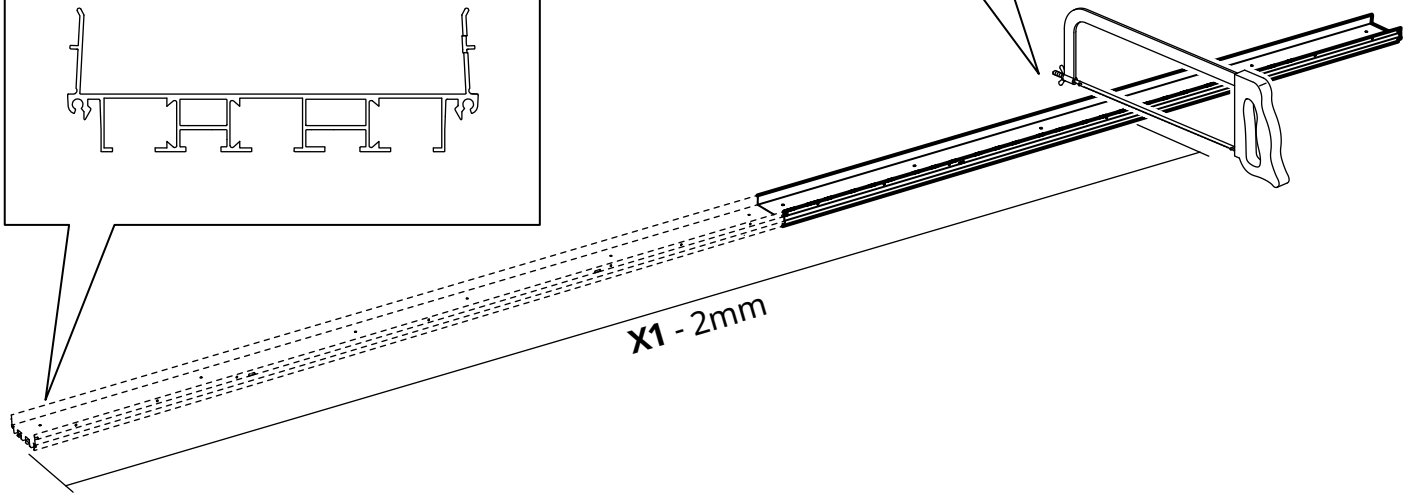
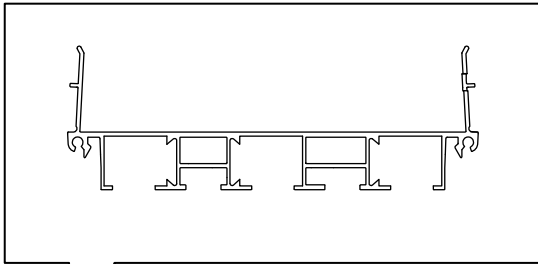
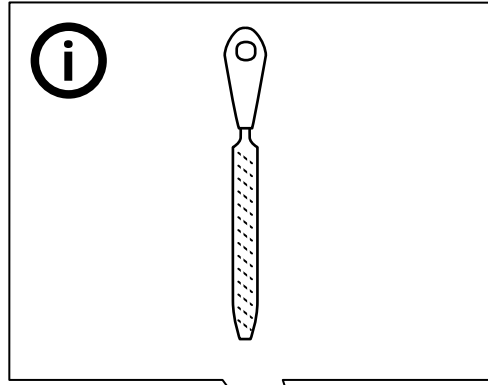

18

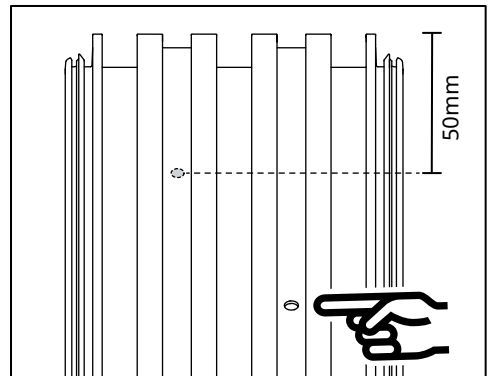
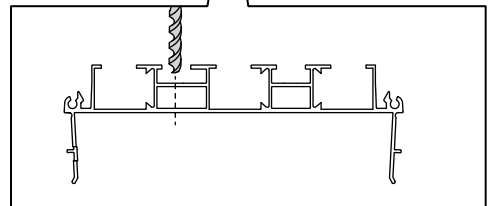
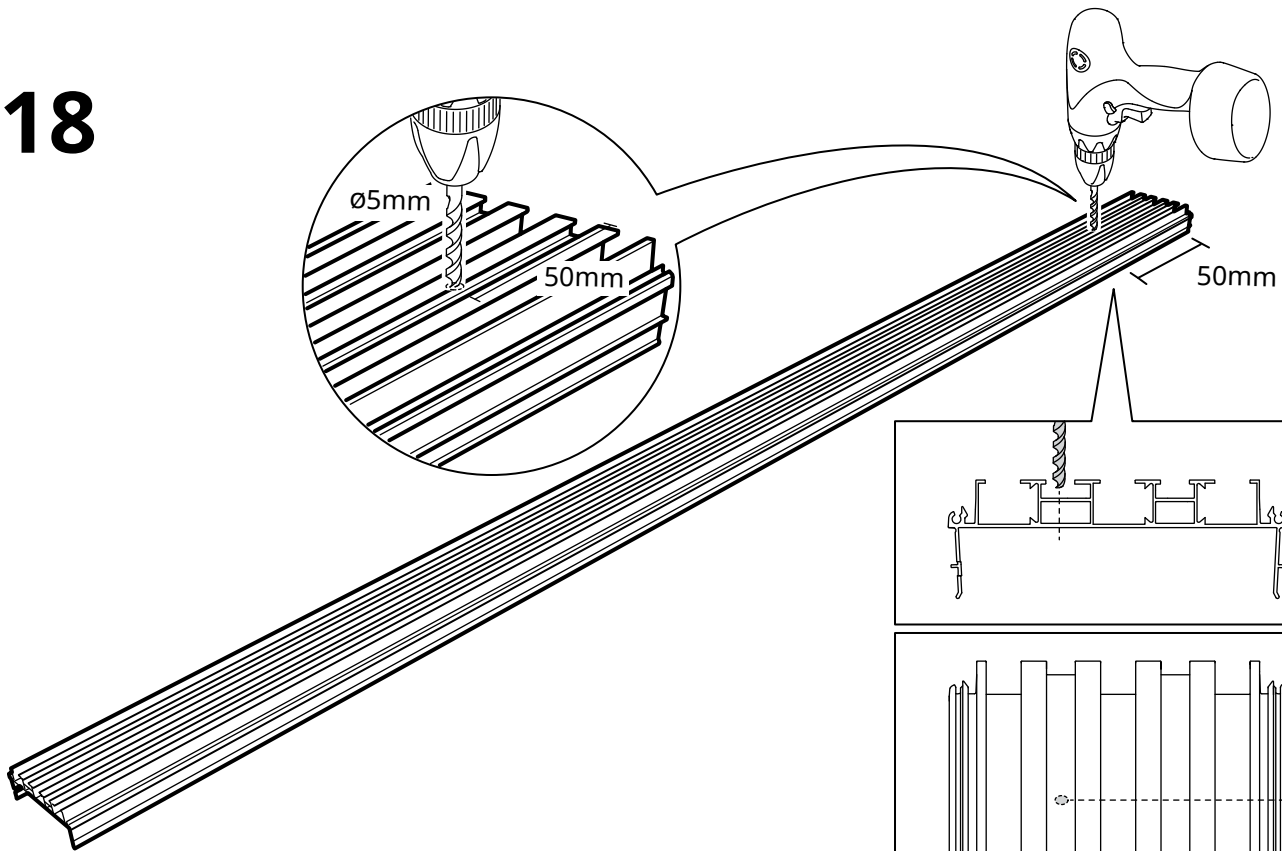
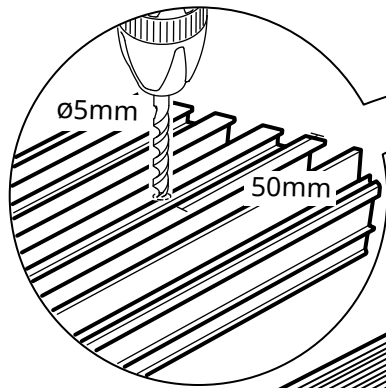

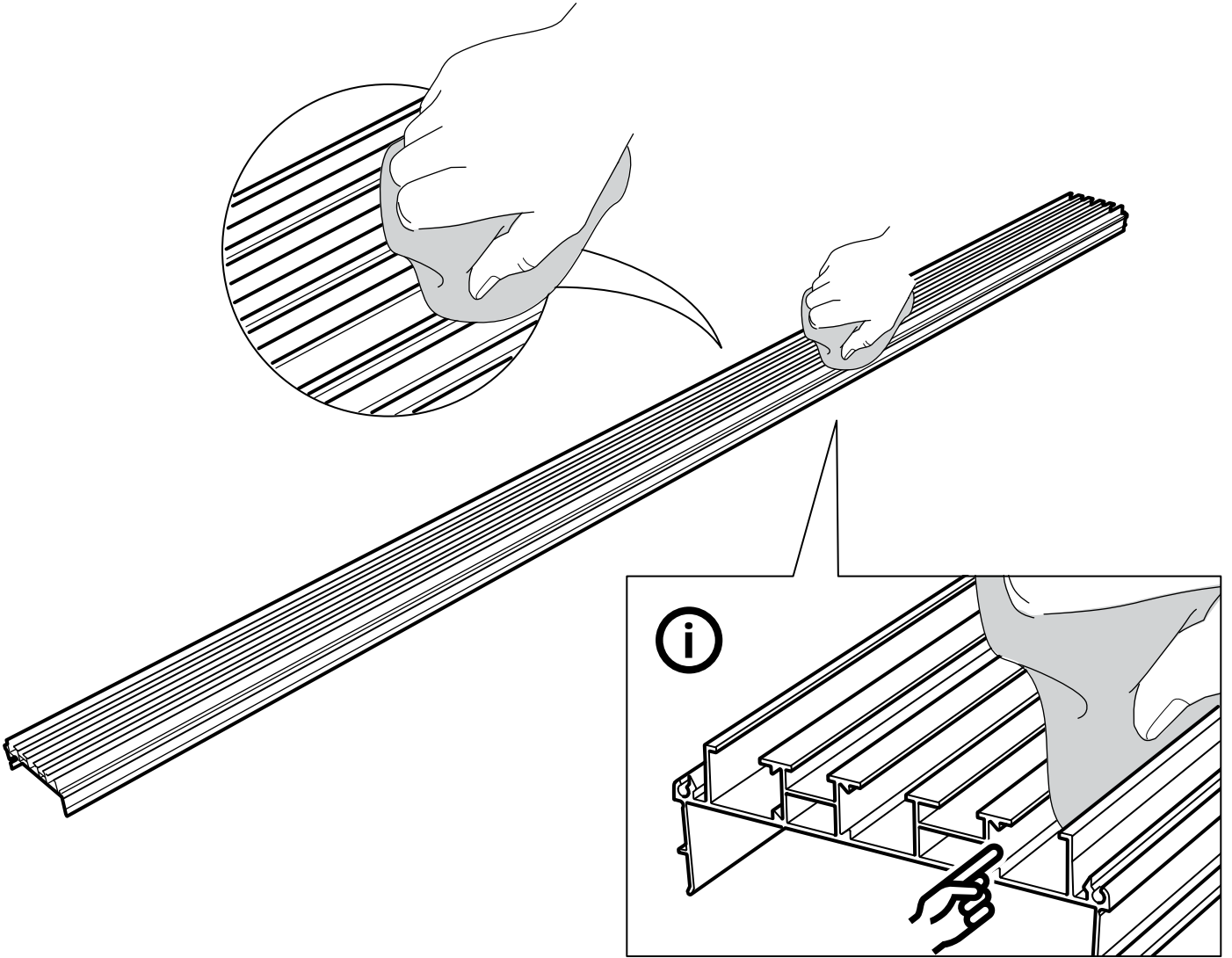

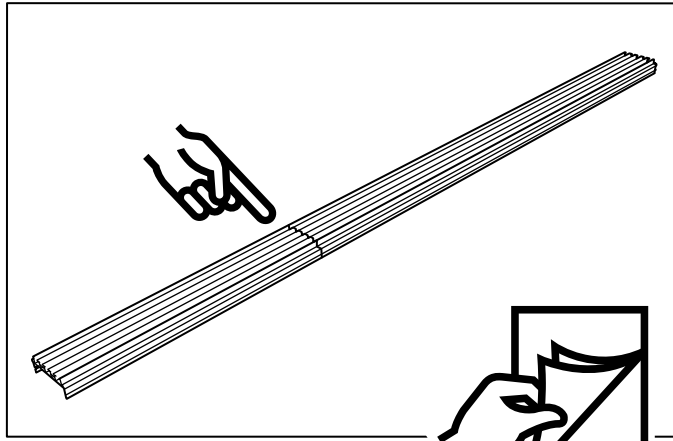
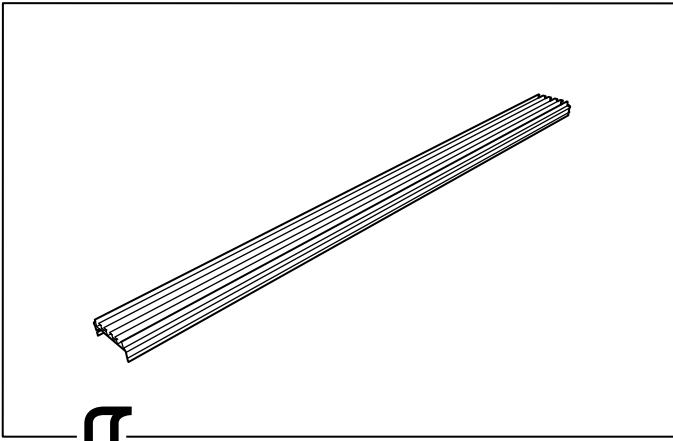

20

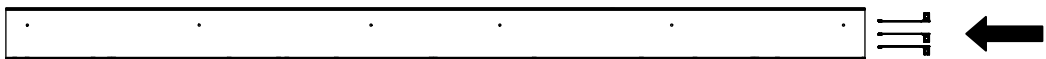
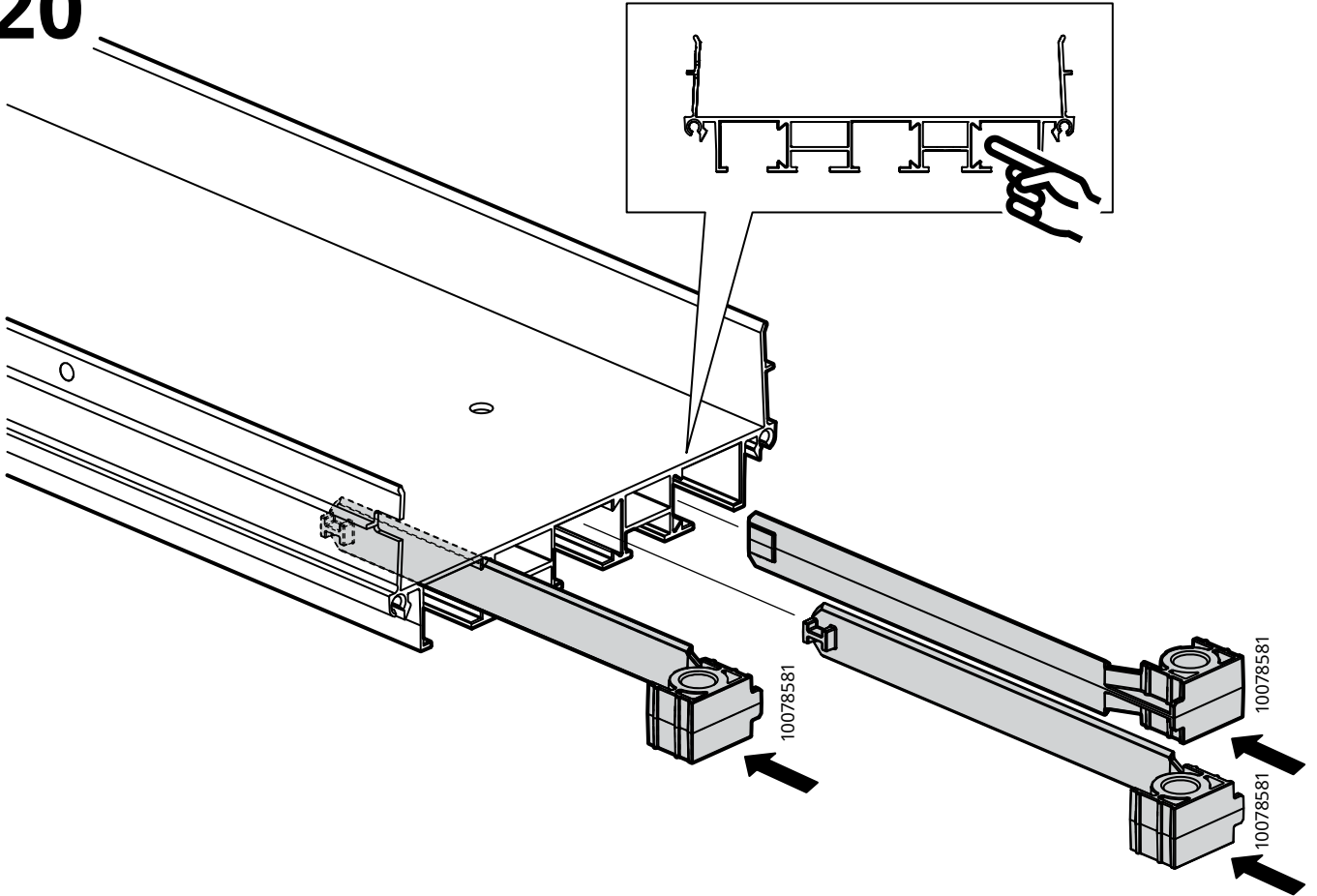

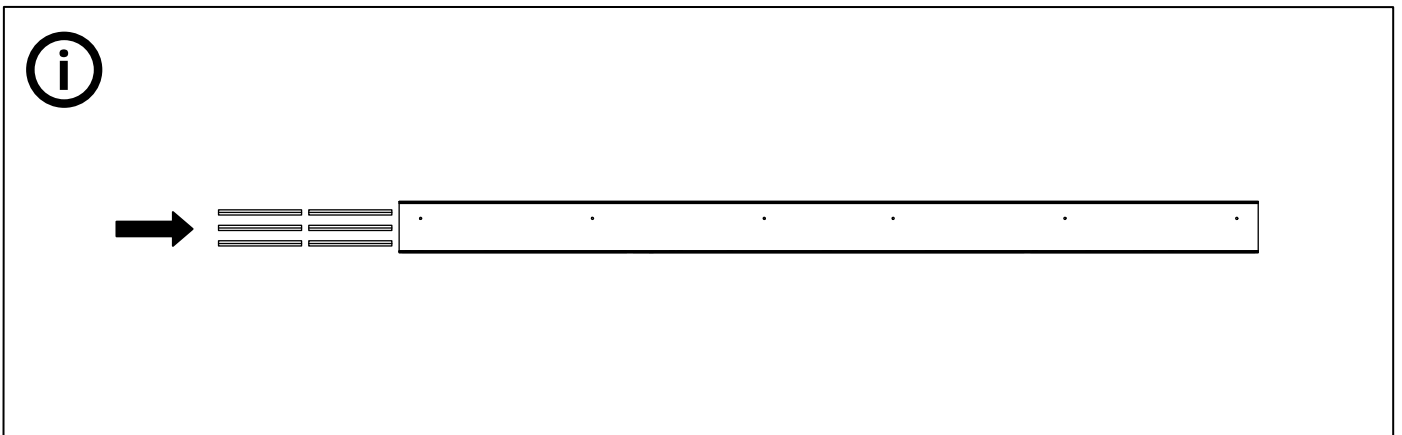
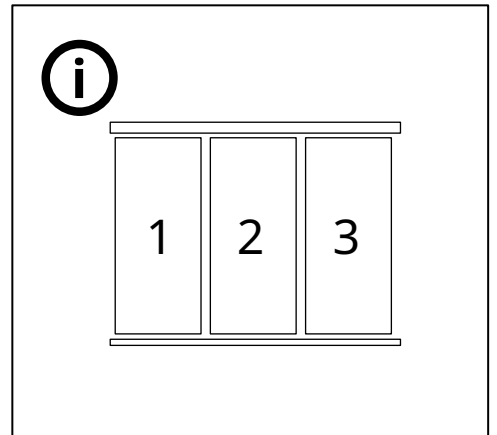
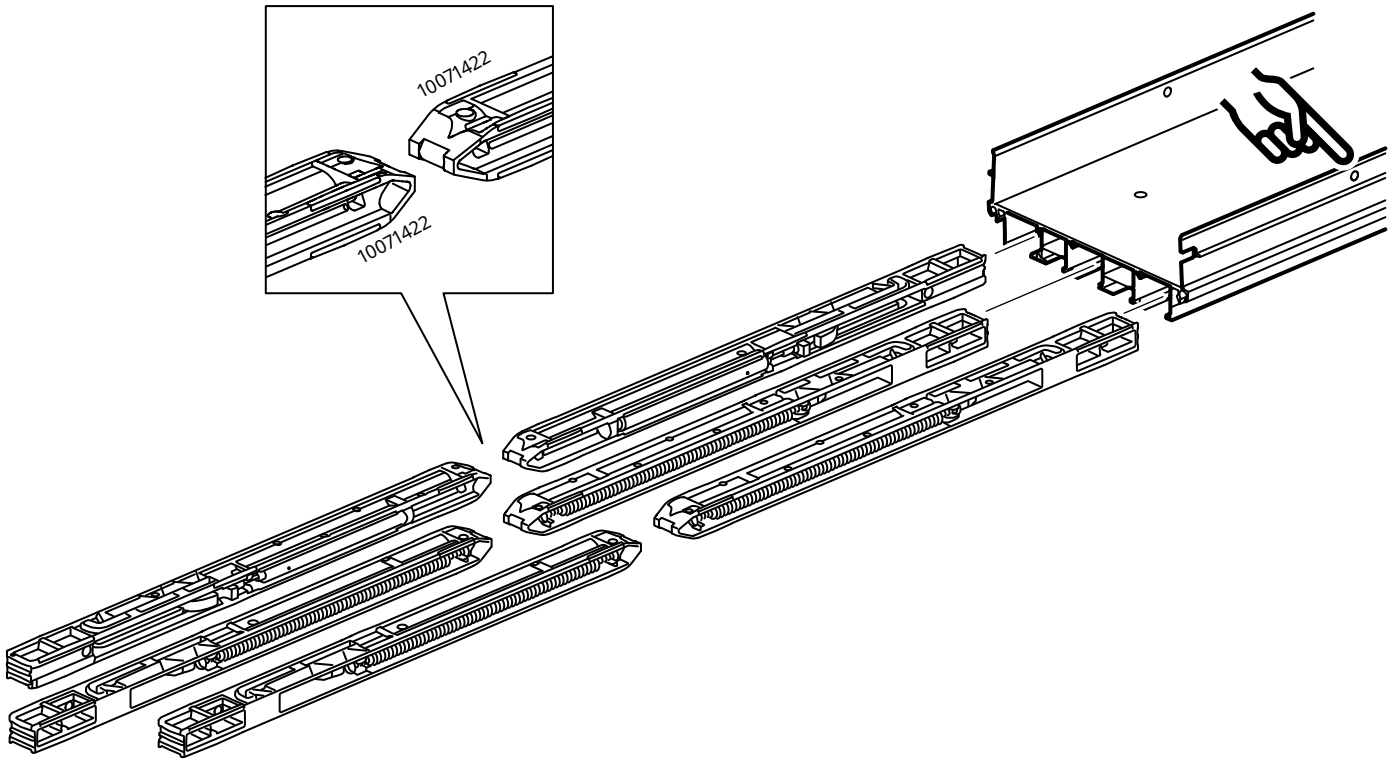

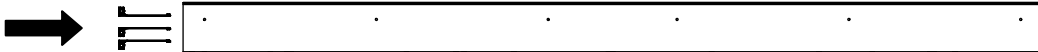
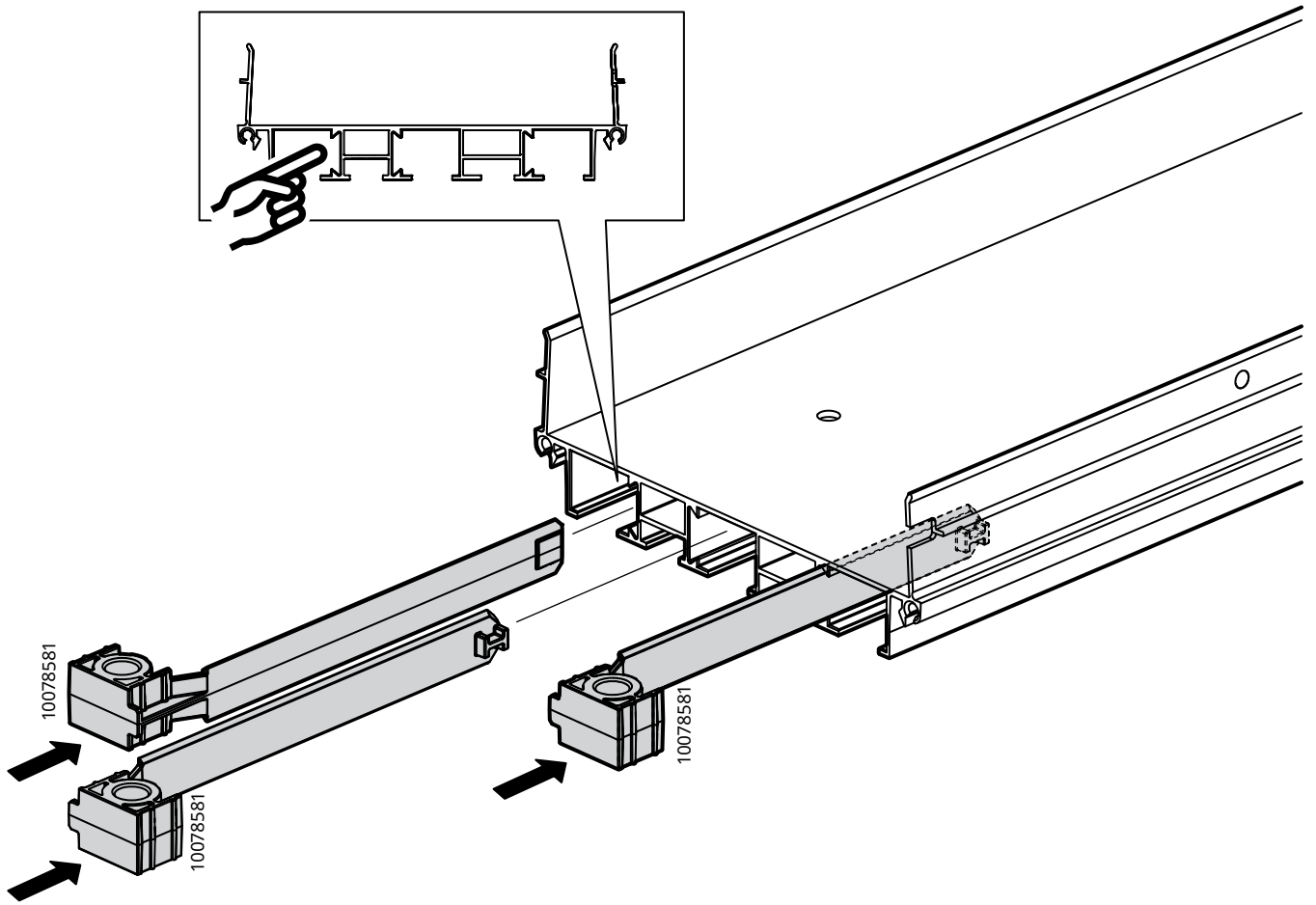

23

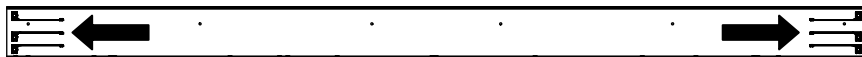
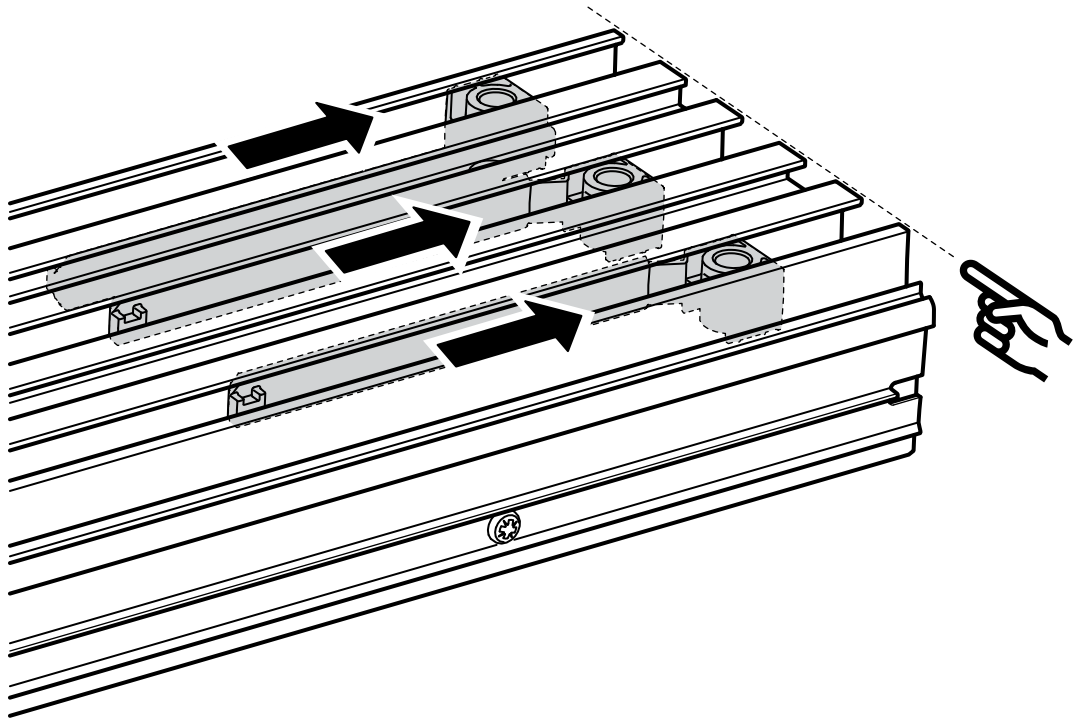
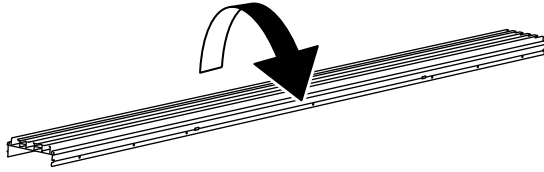

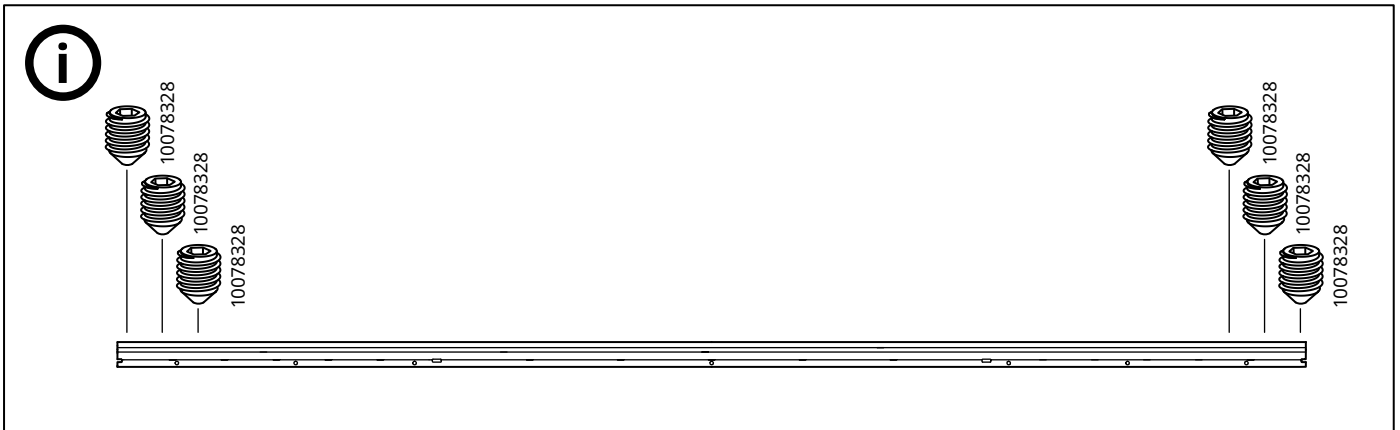
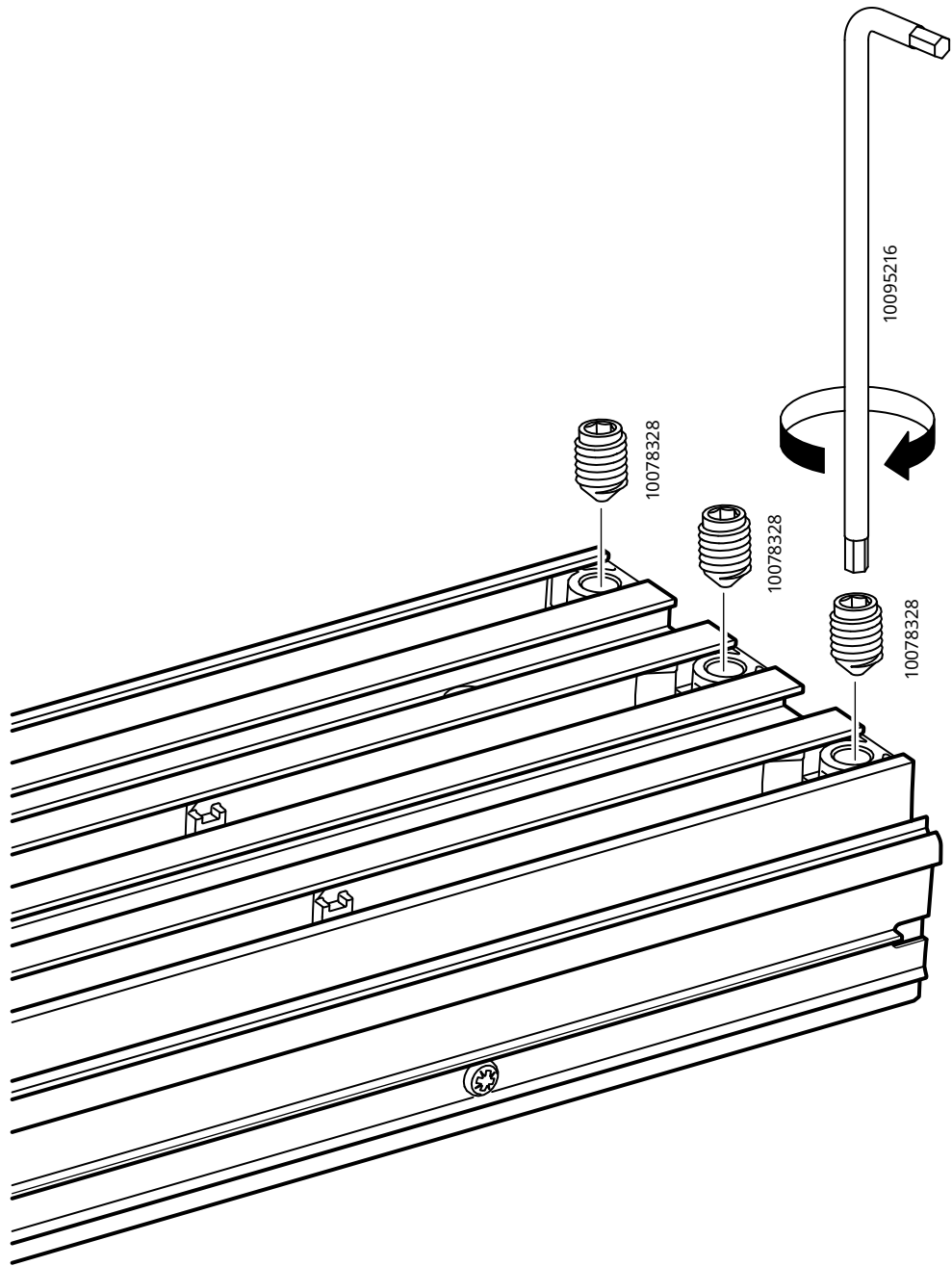

25

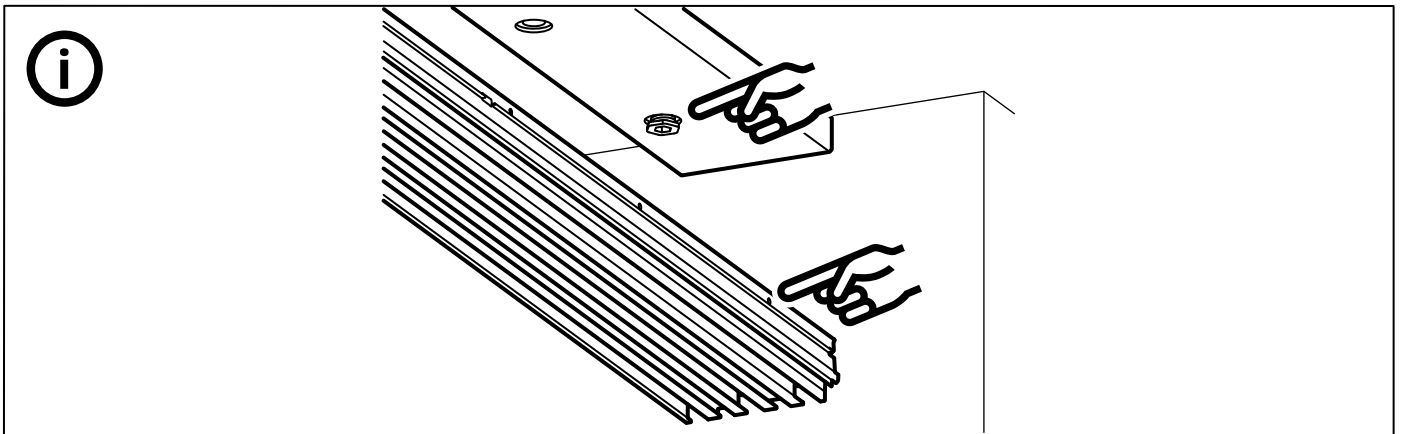
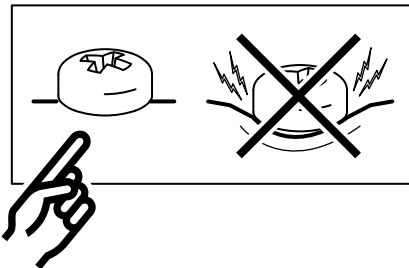
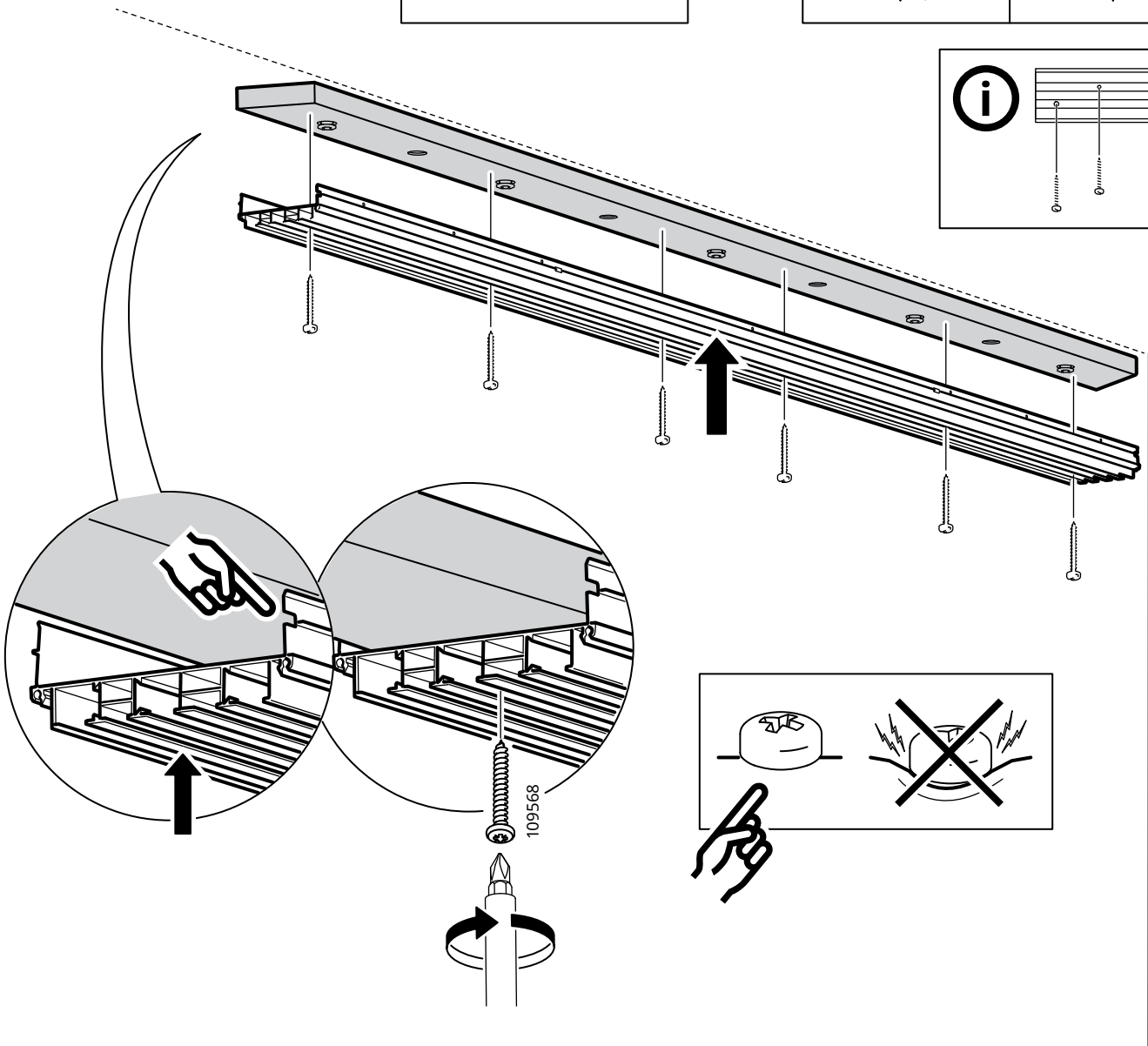
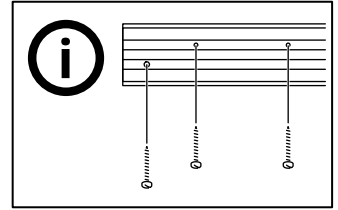
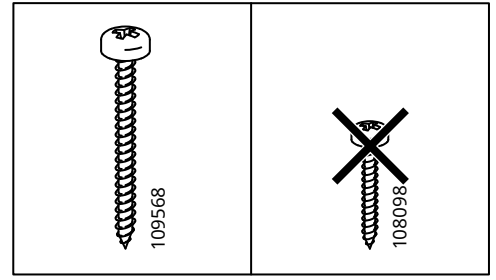
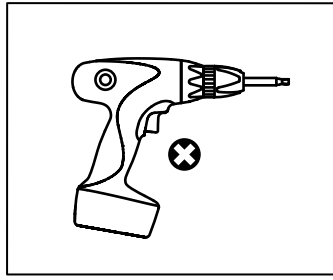

26

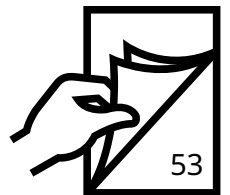
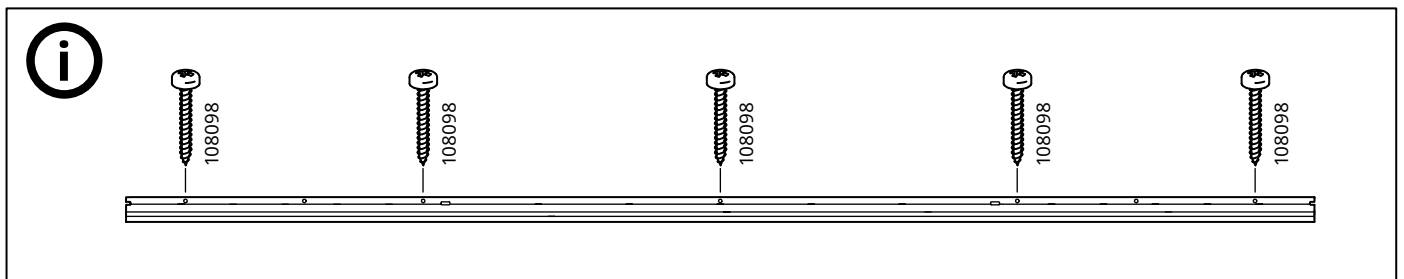
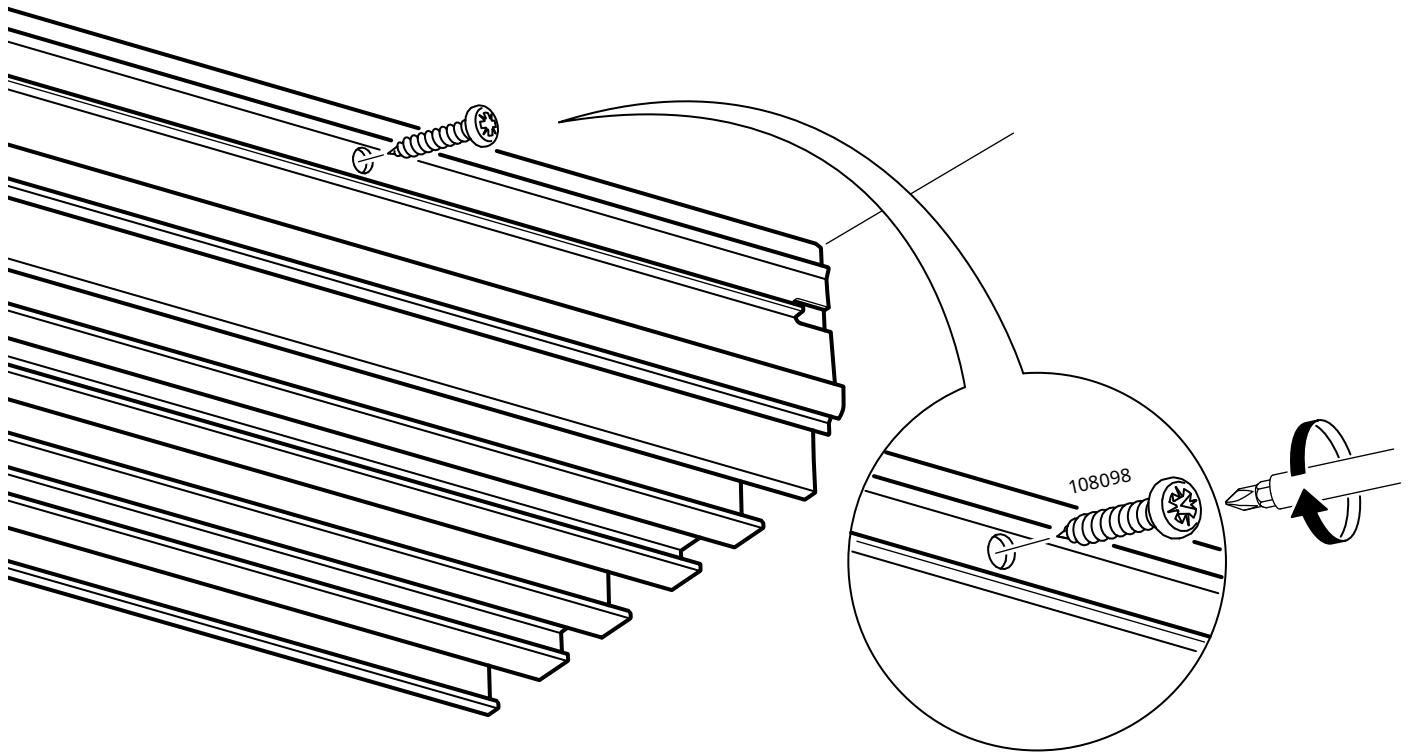

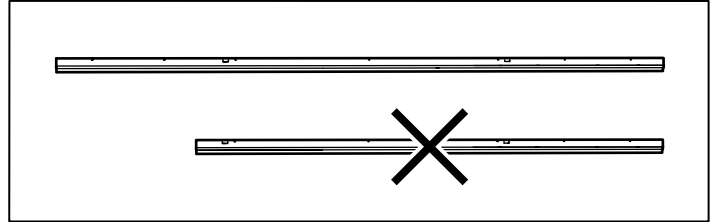
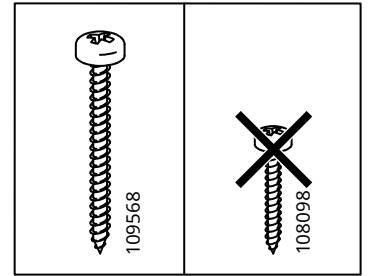
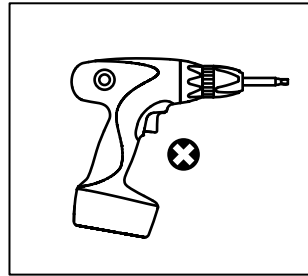
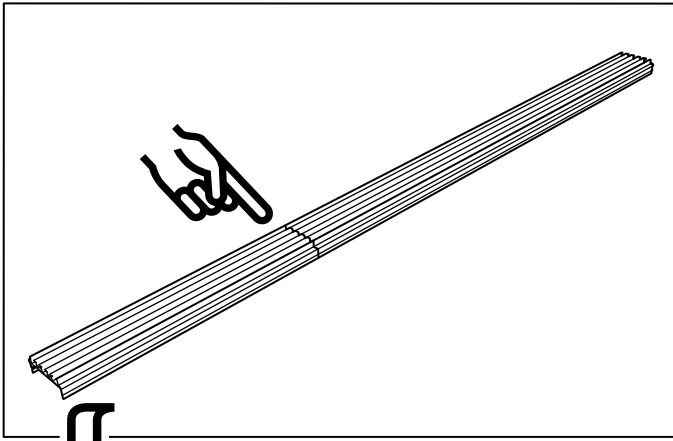

27

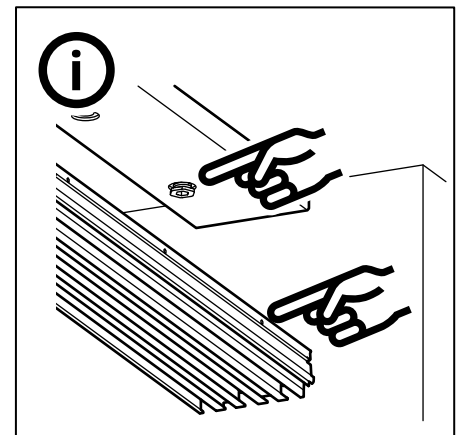
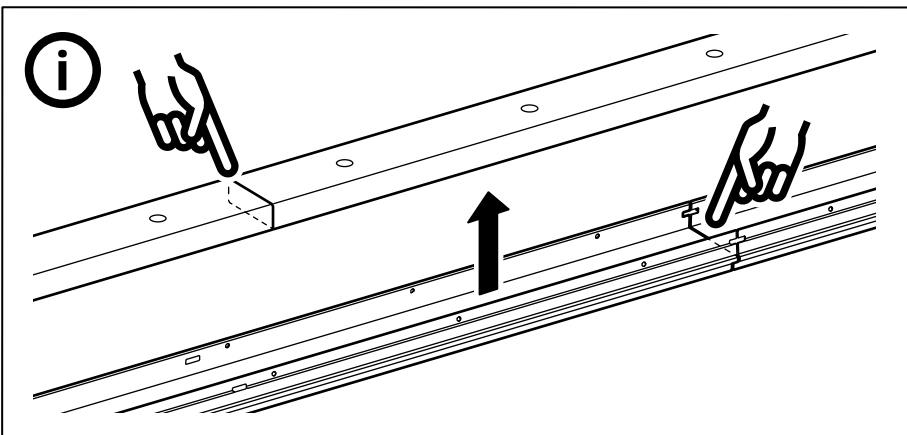
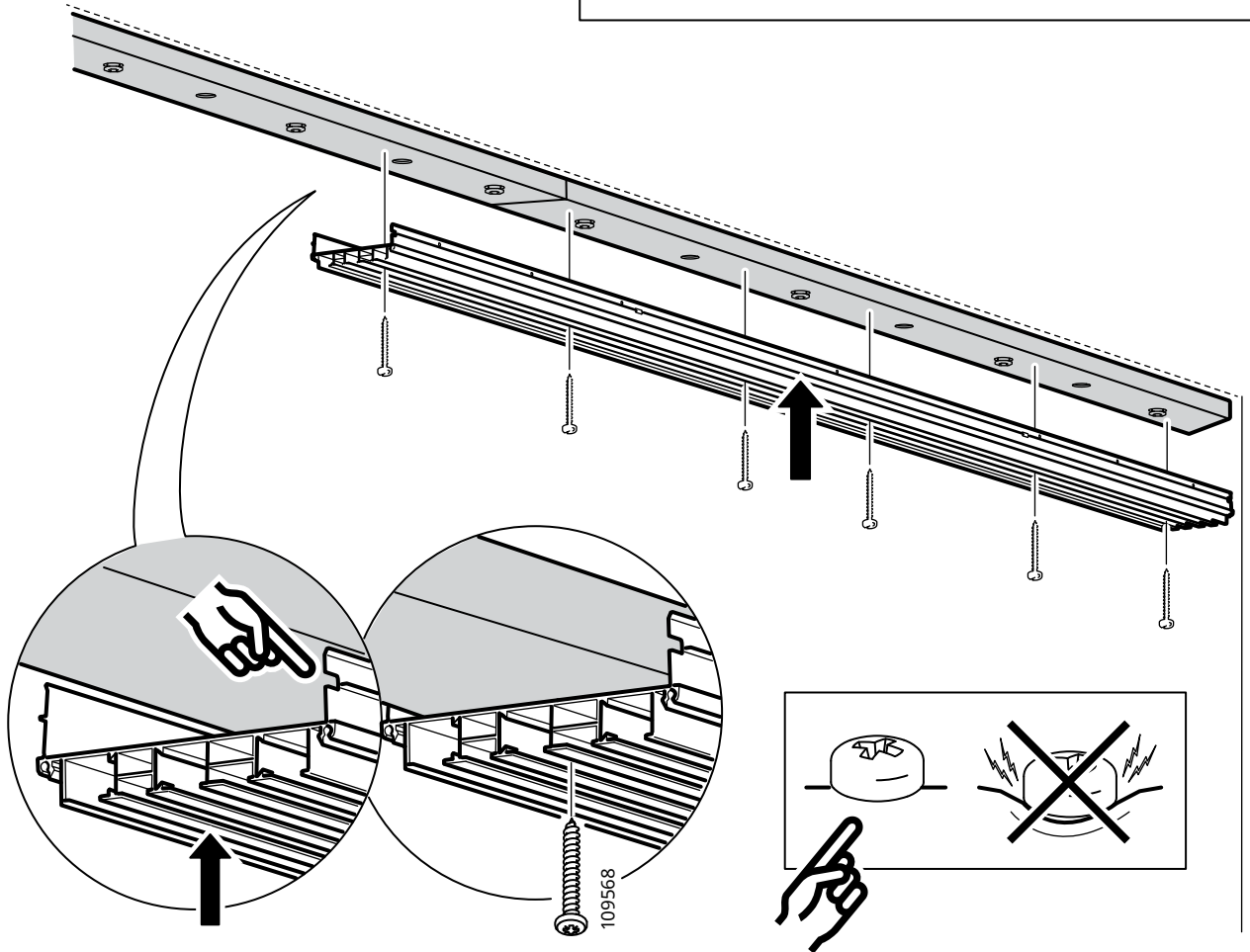

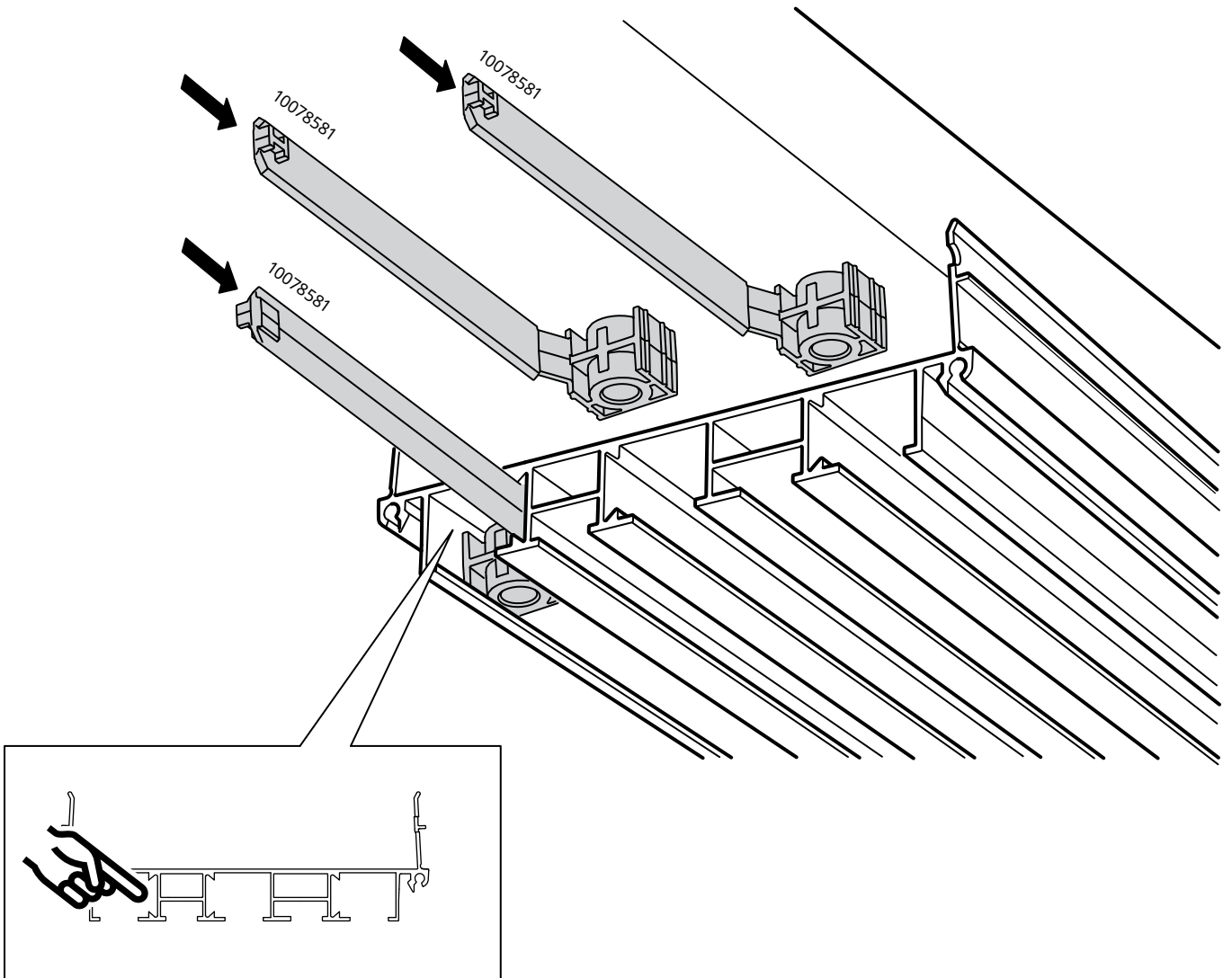

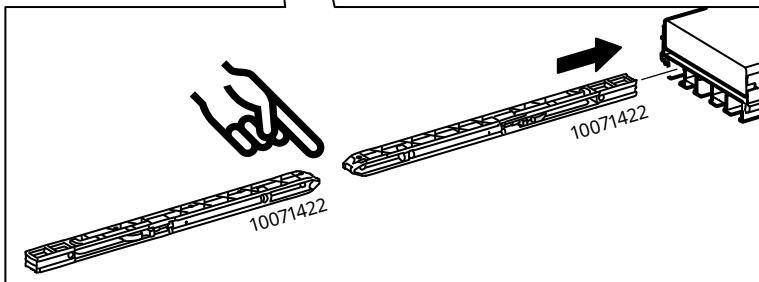
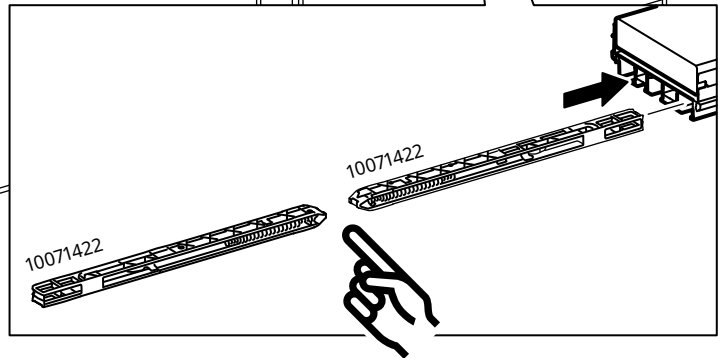
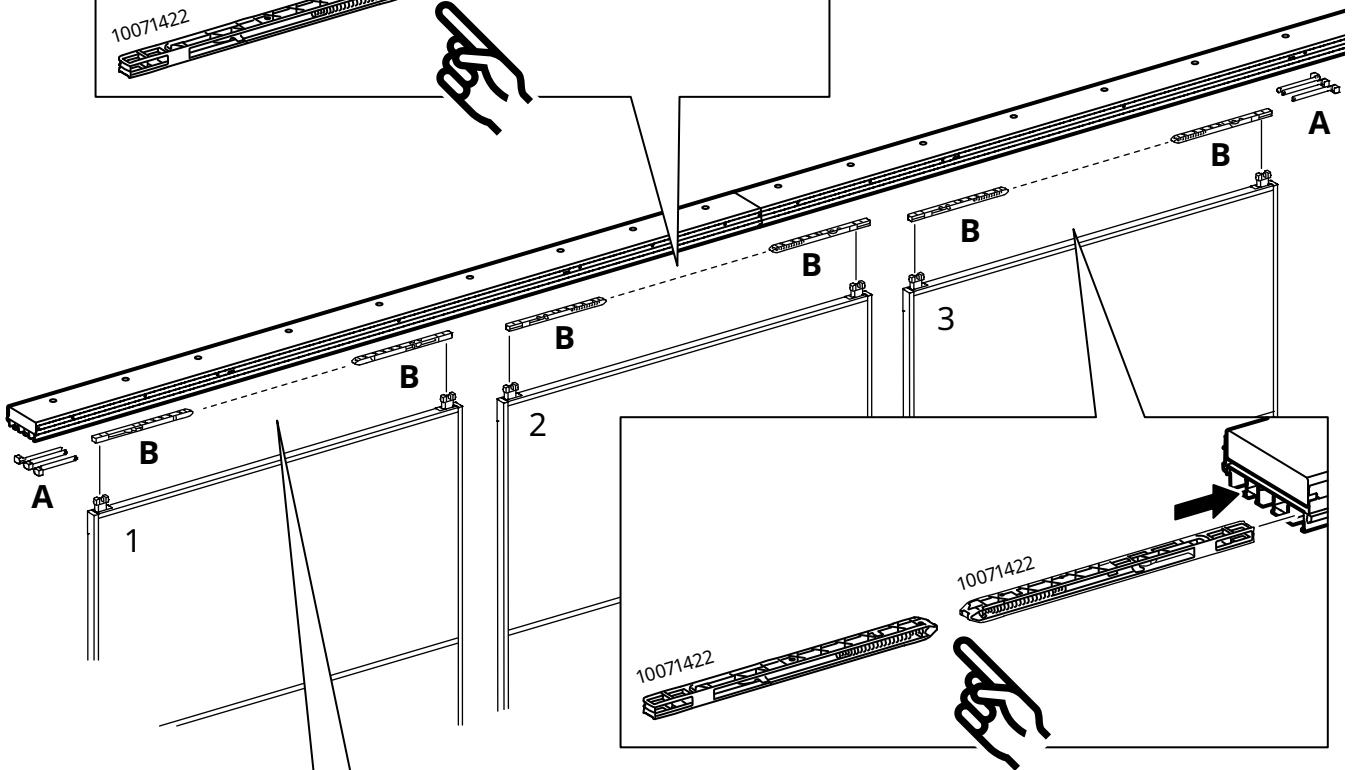
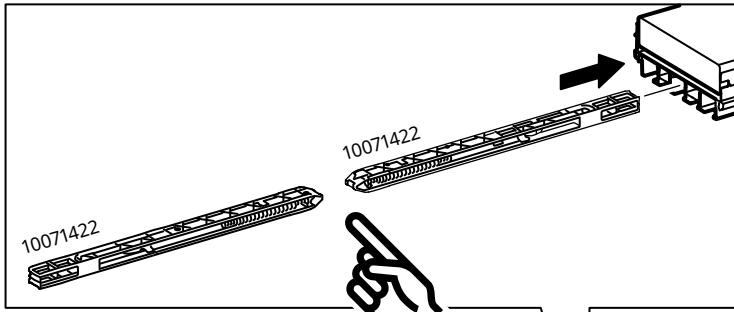
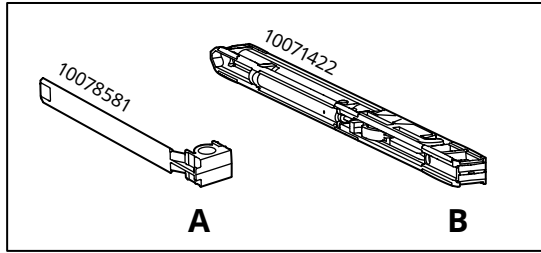
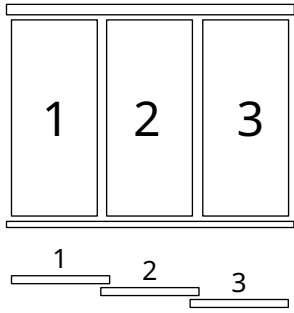

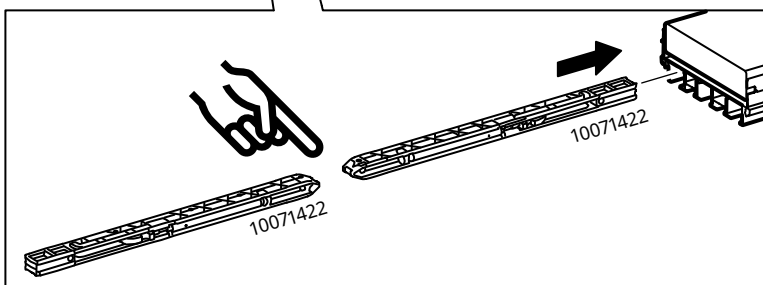
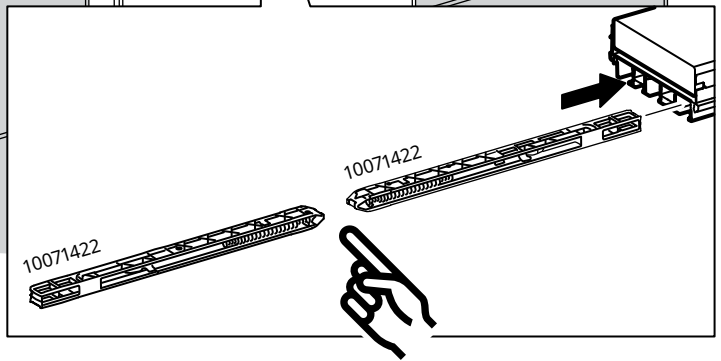
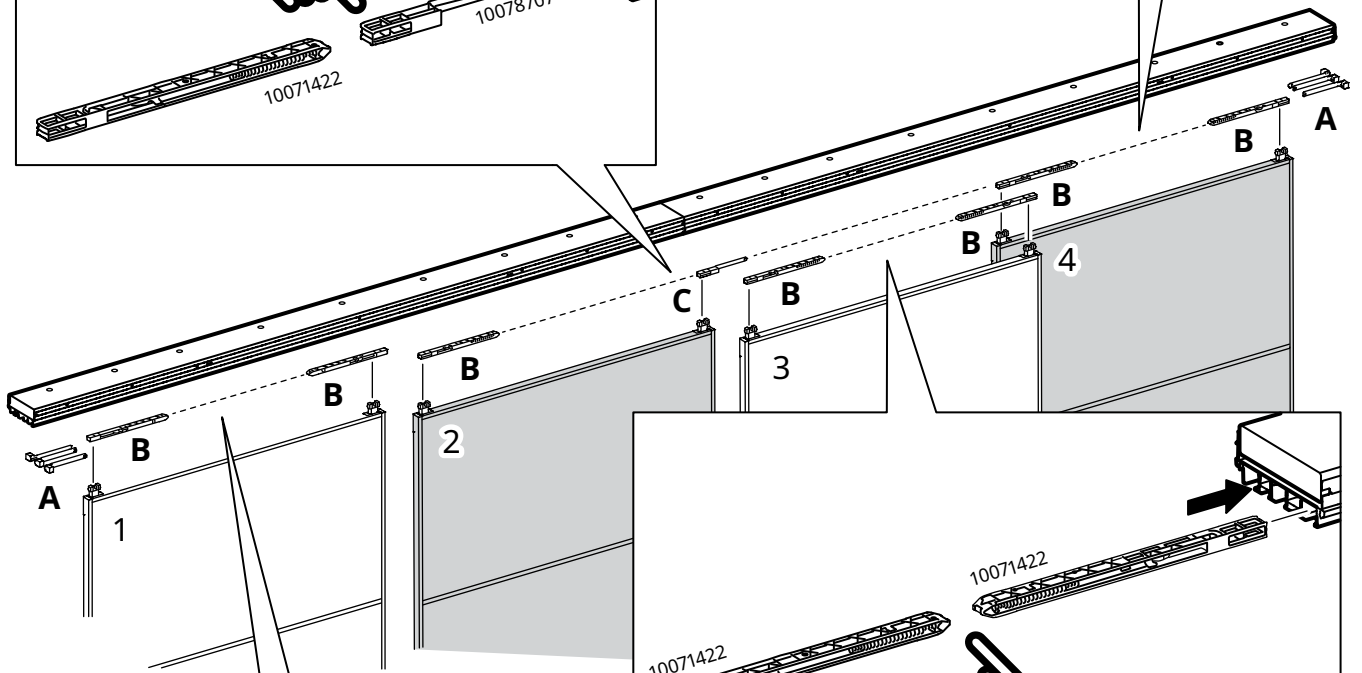
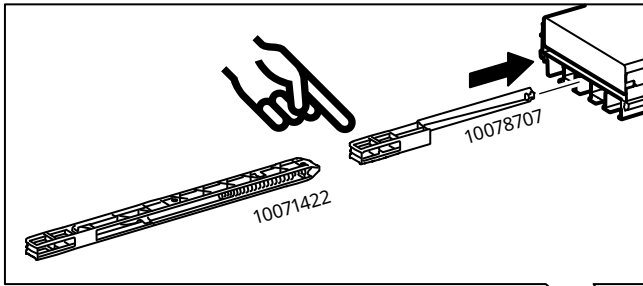
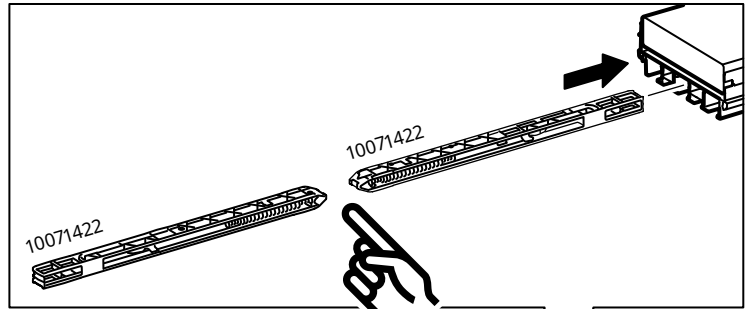
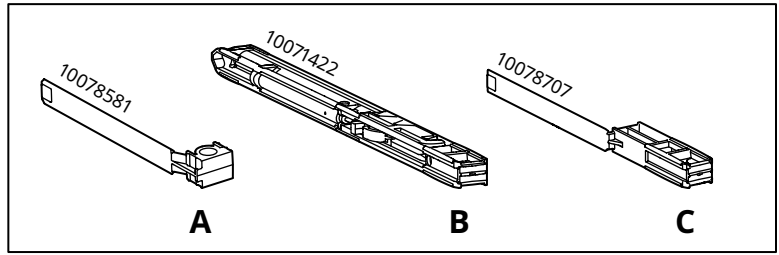
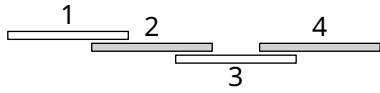
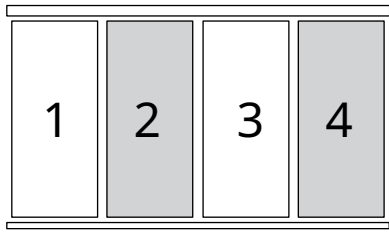

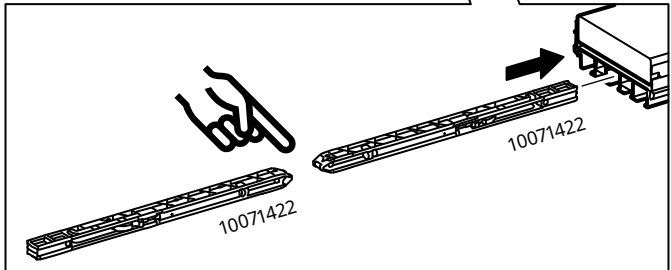
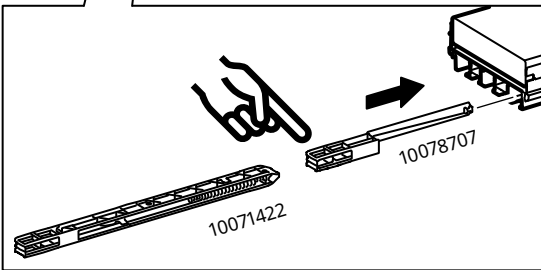
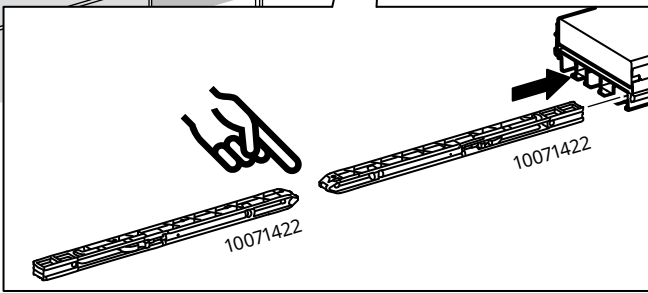
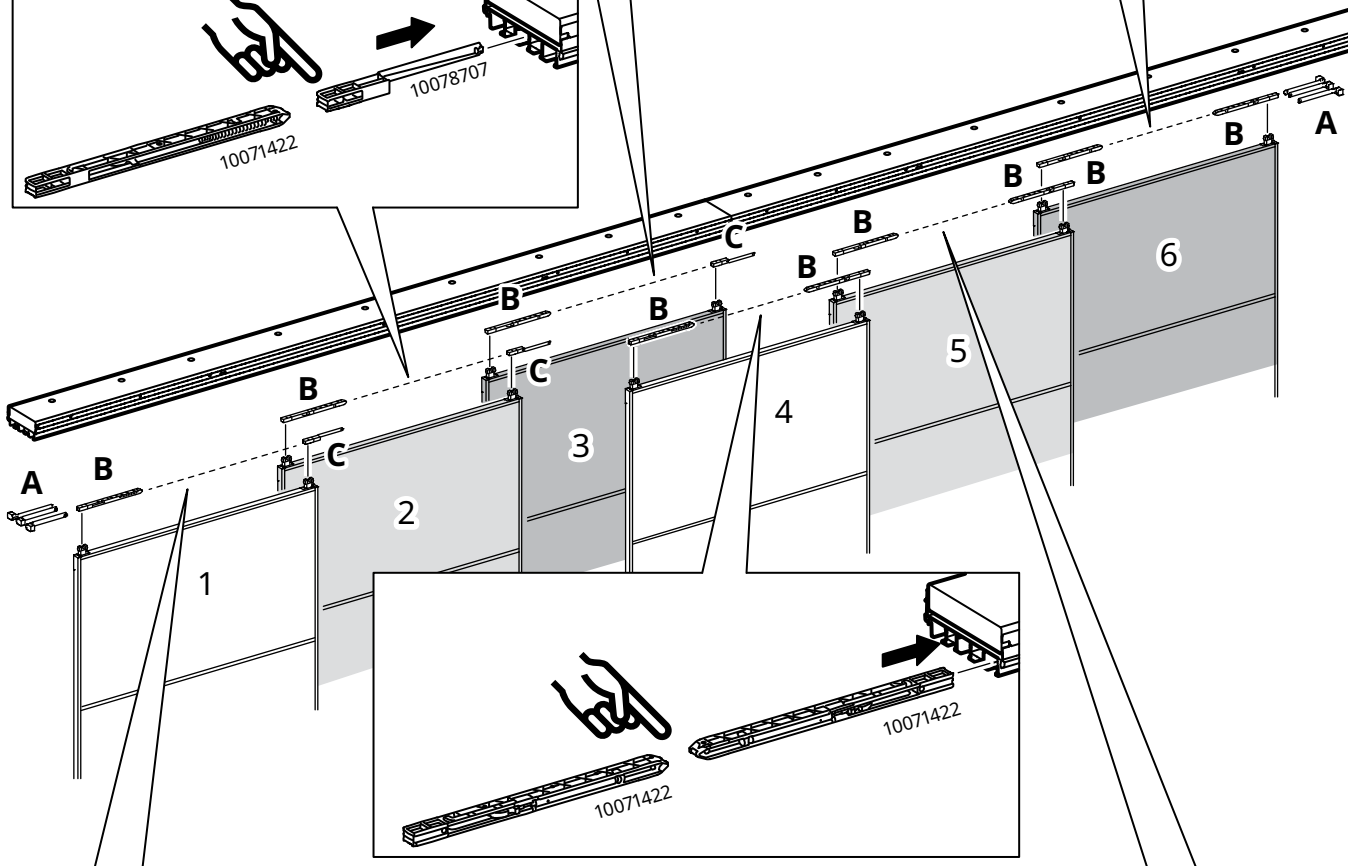
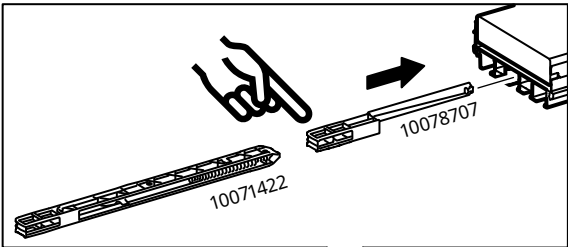
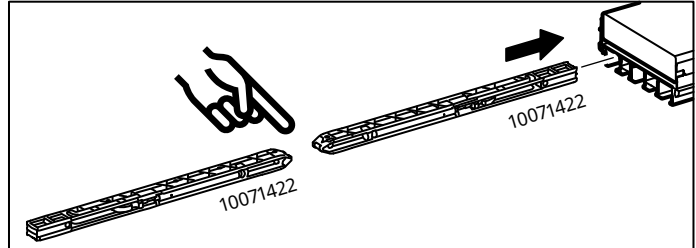
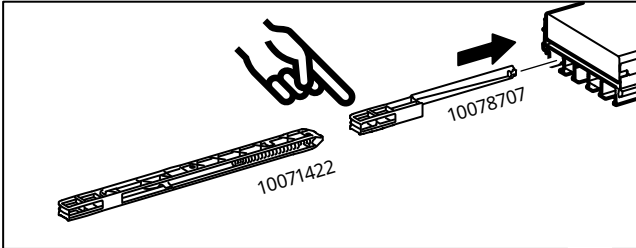
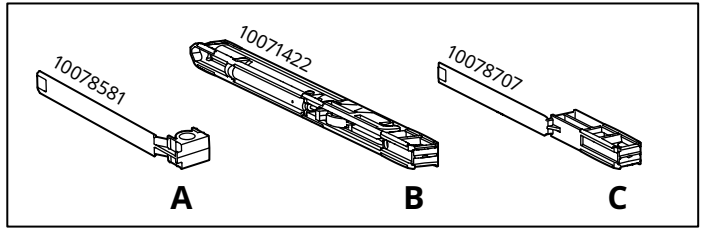
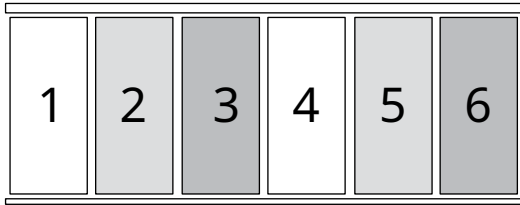

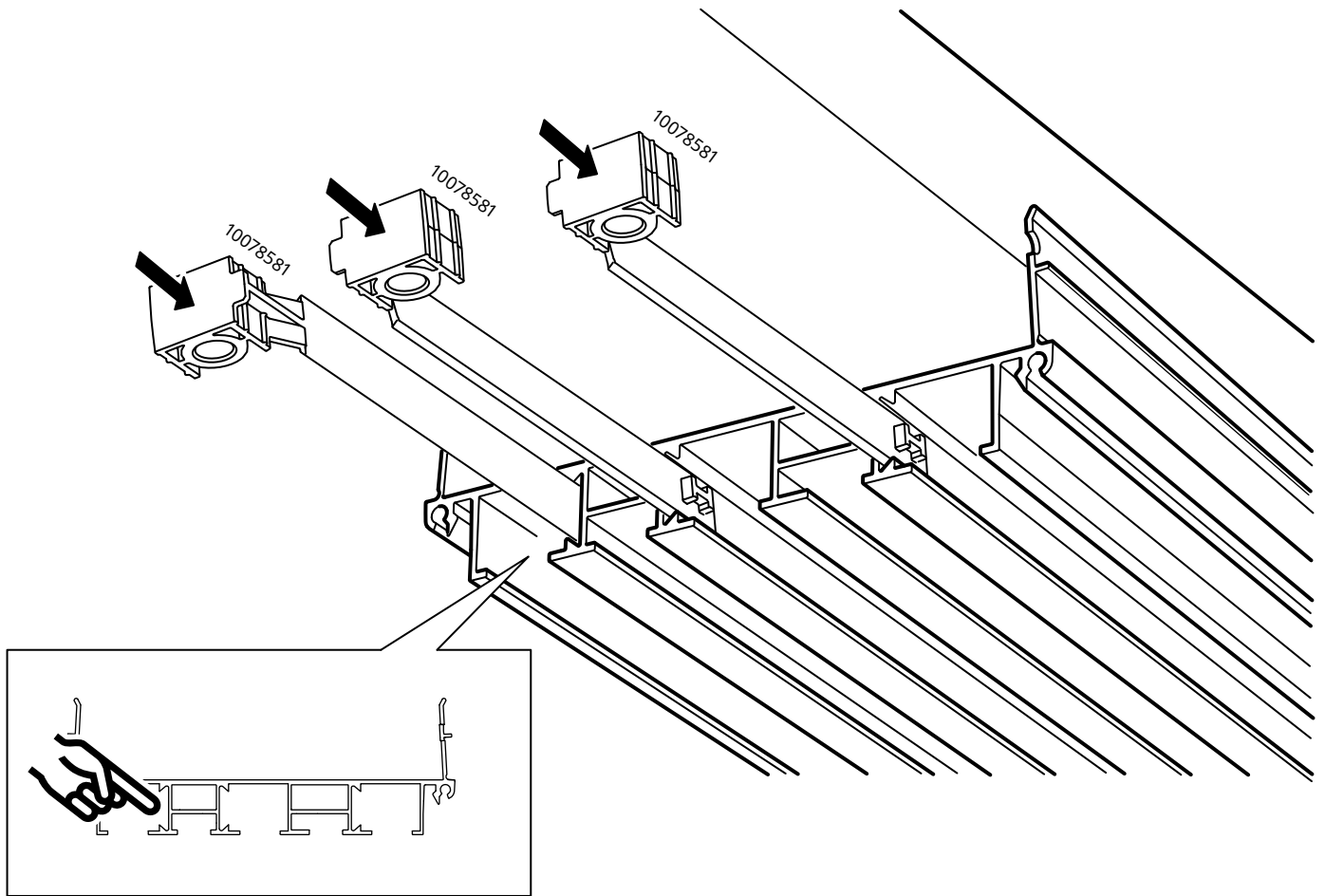

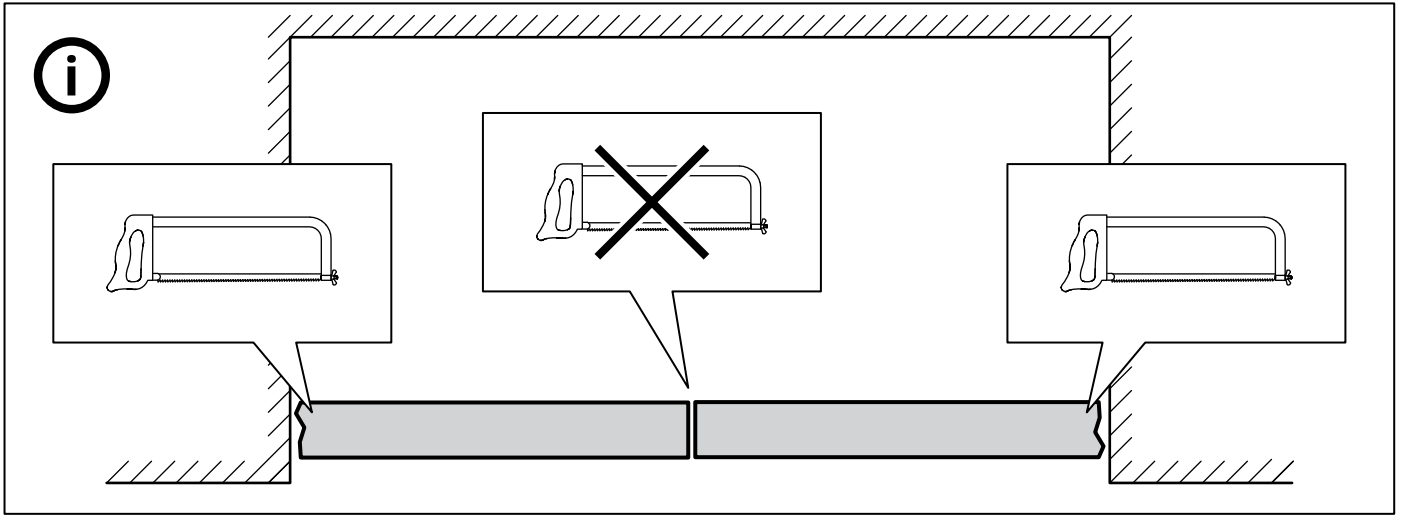

30

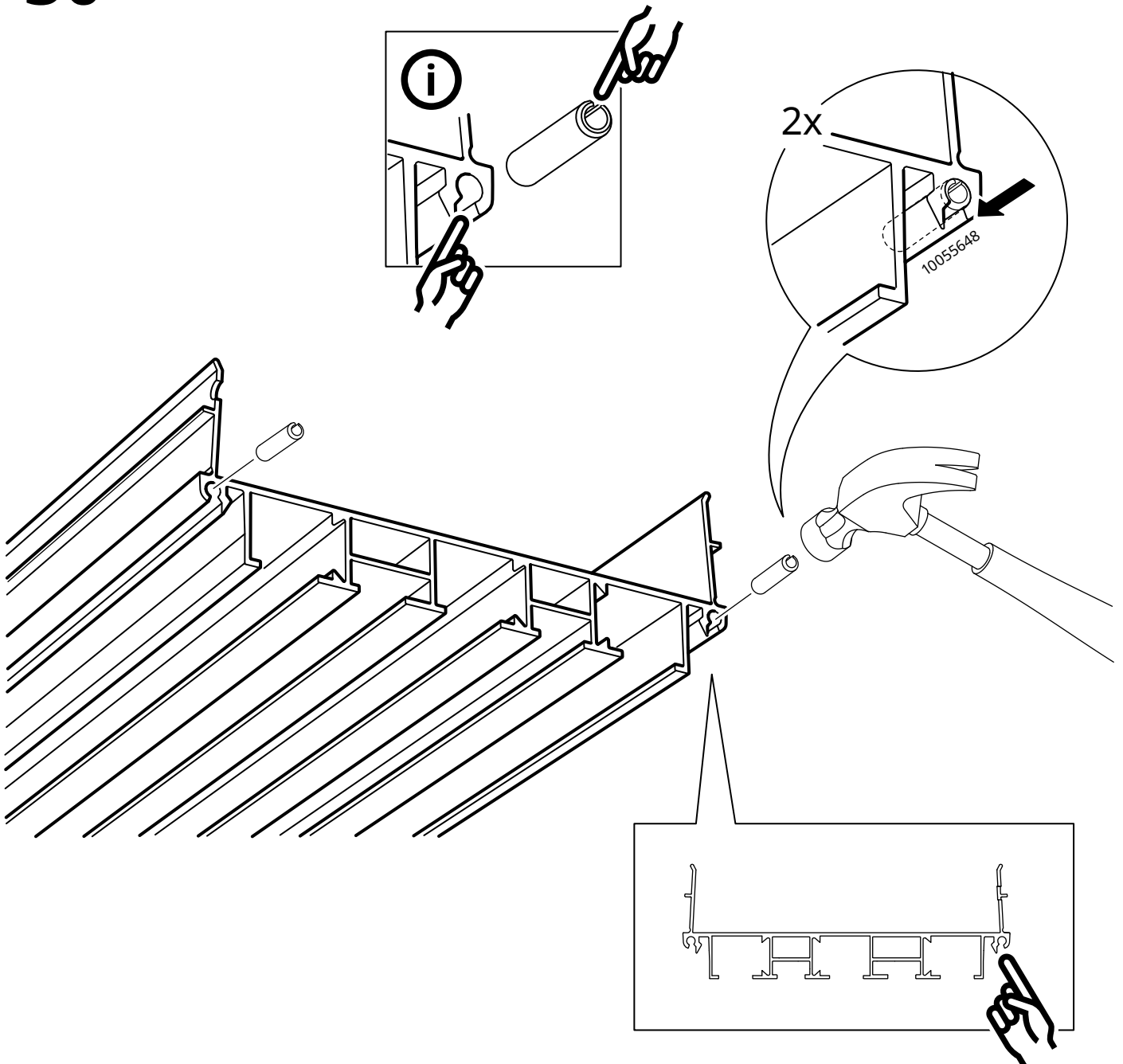

31

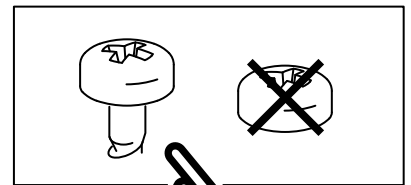
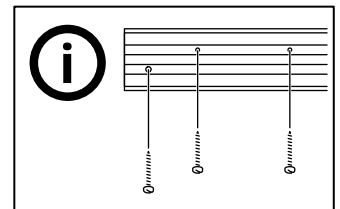
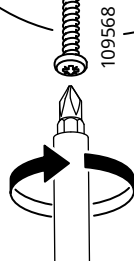
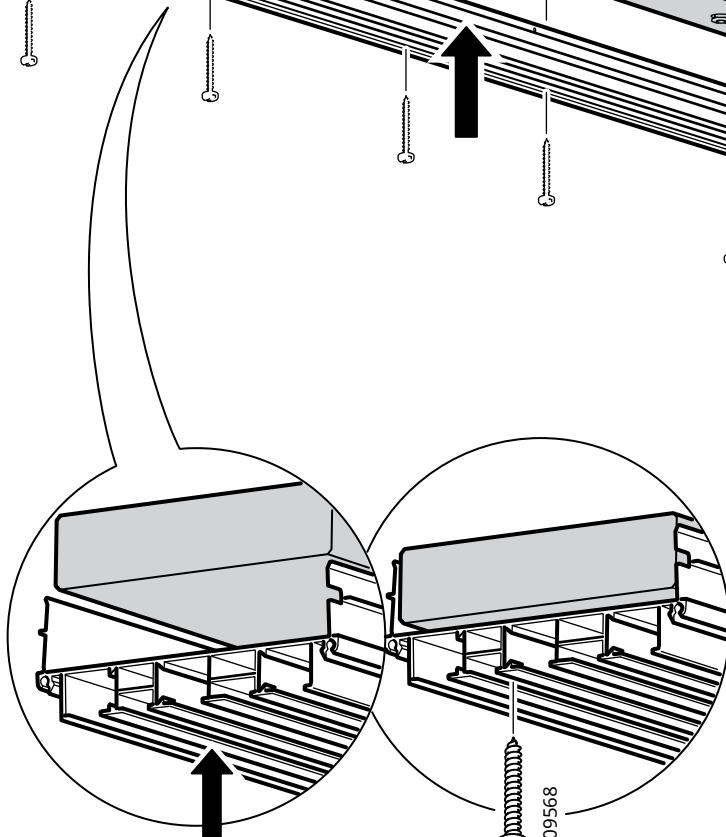
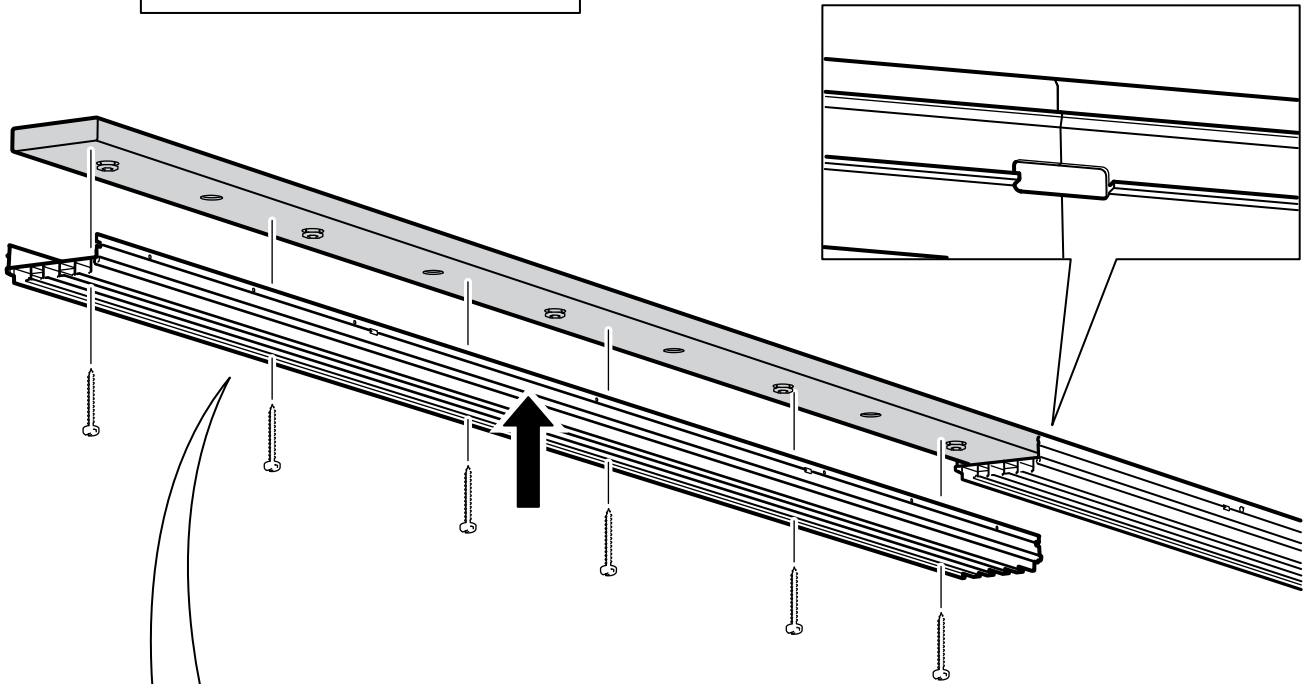
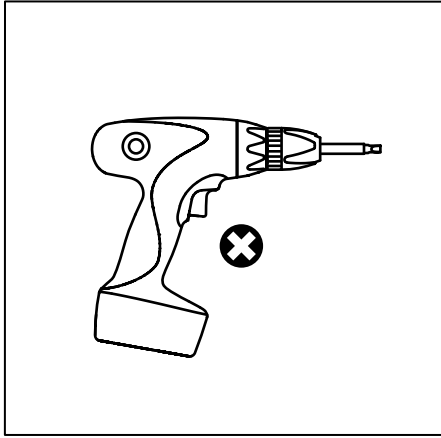

32

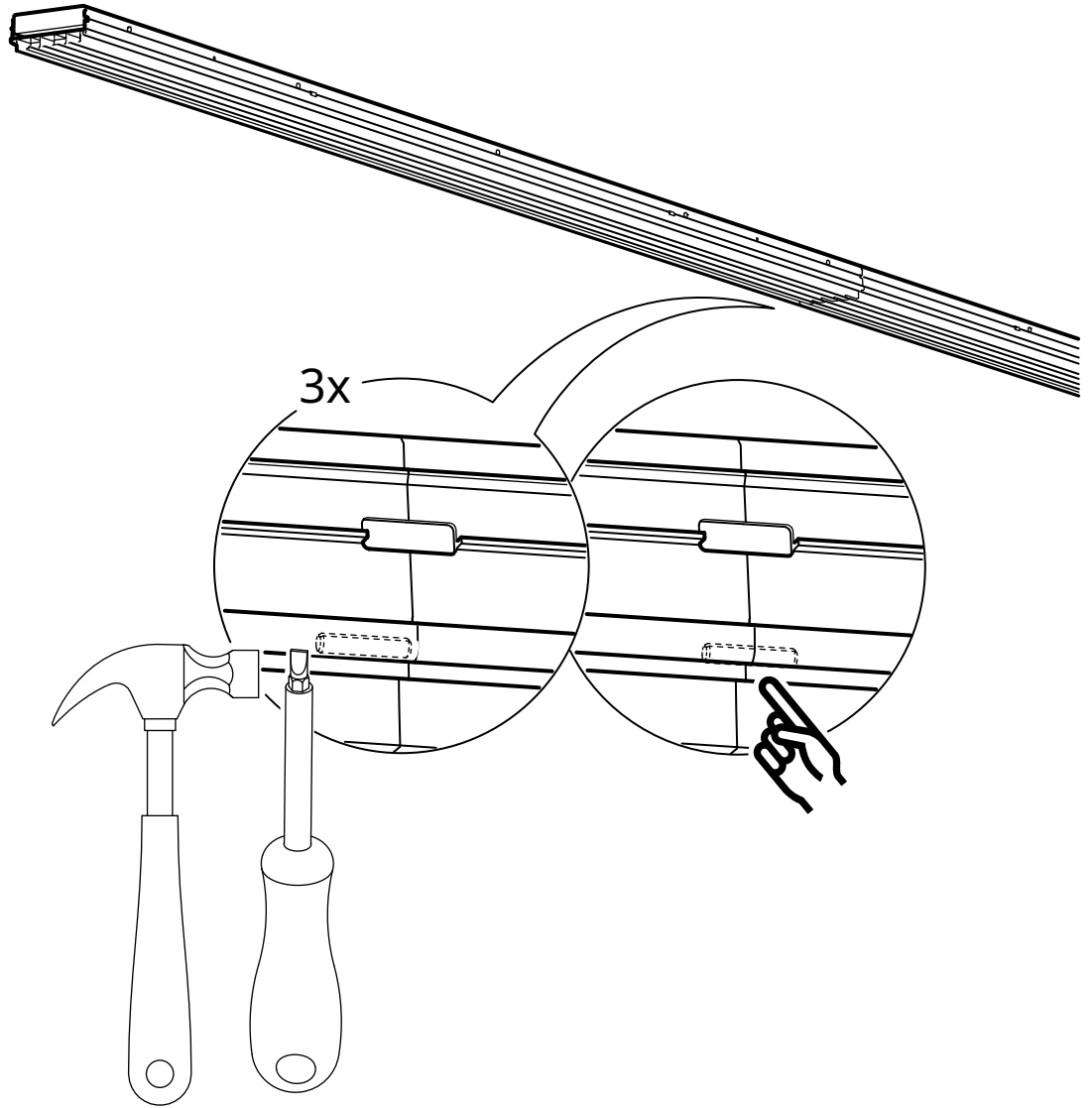

33

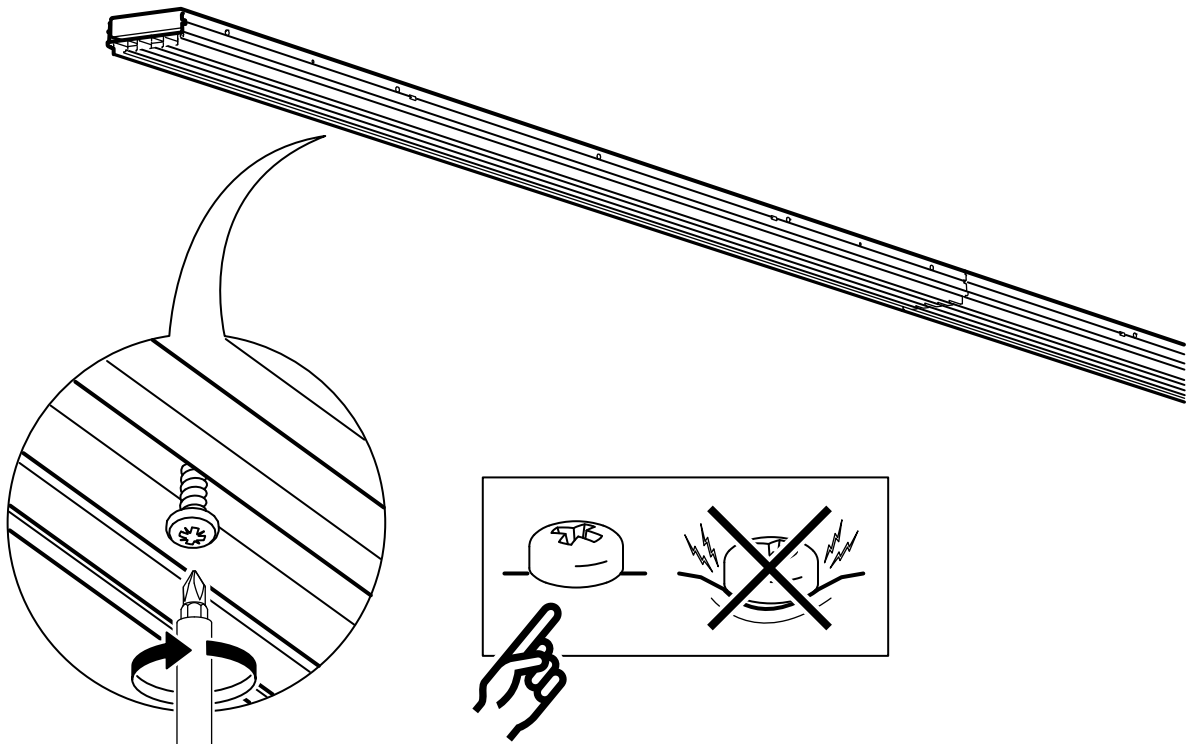

34

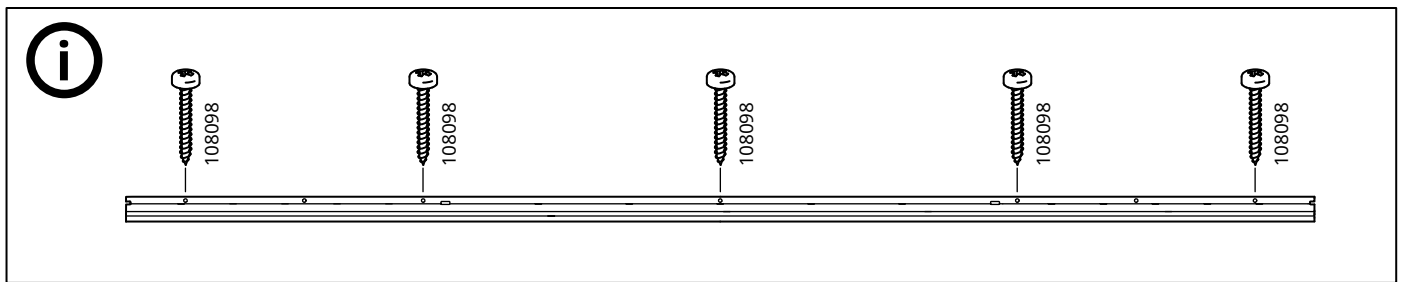
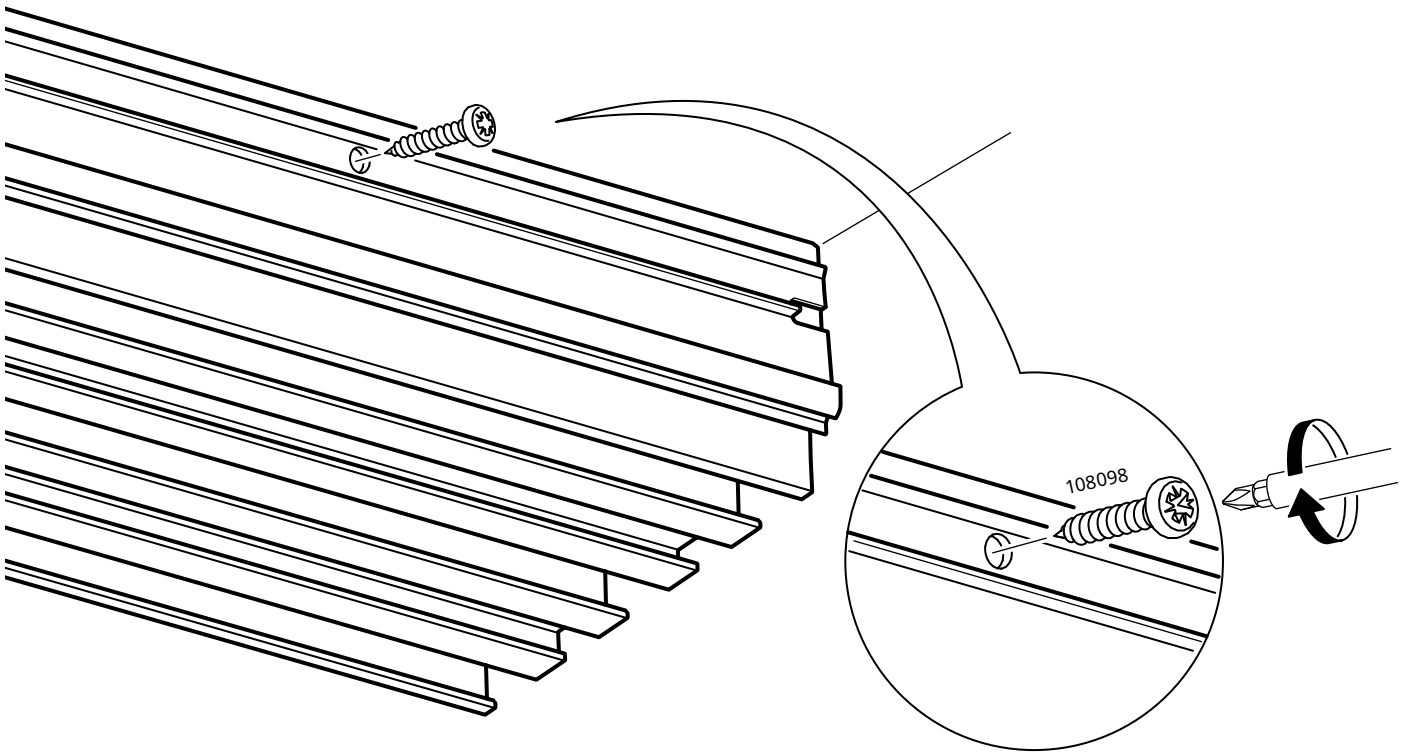

35

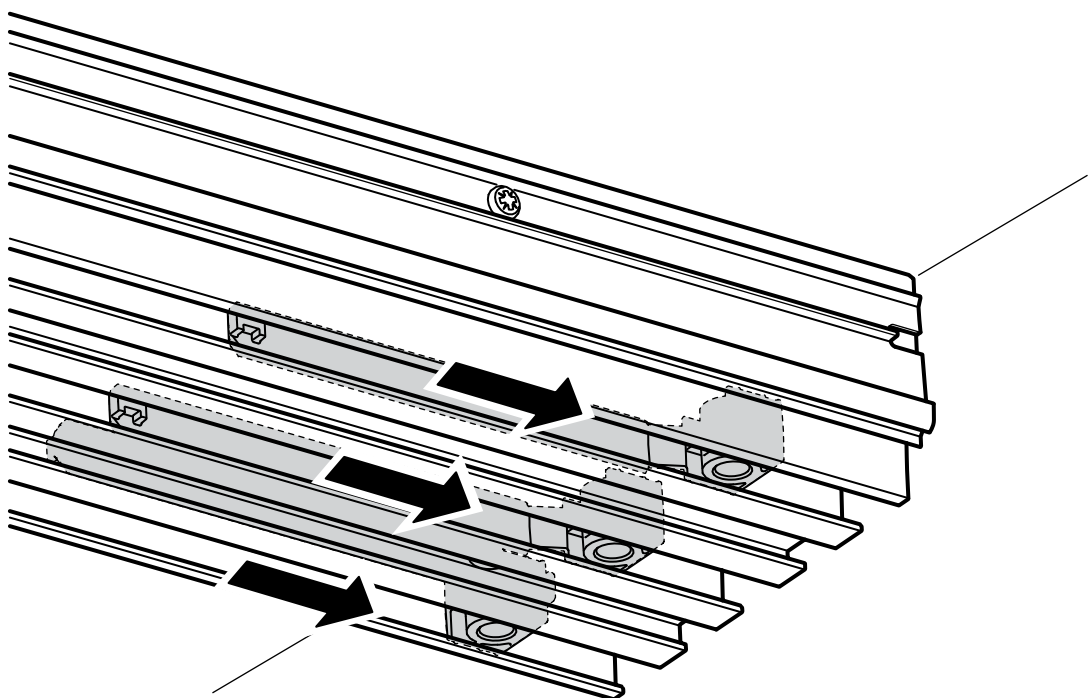

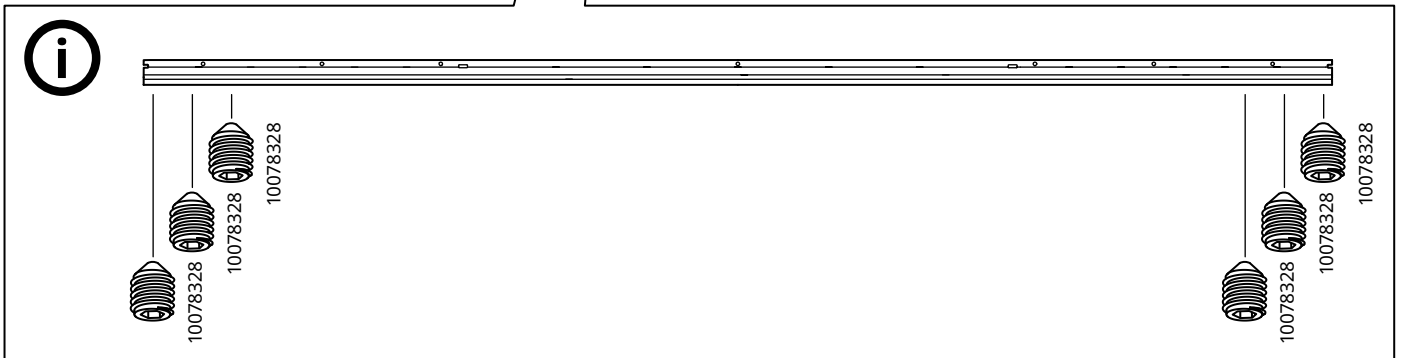
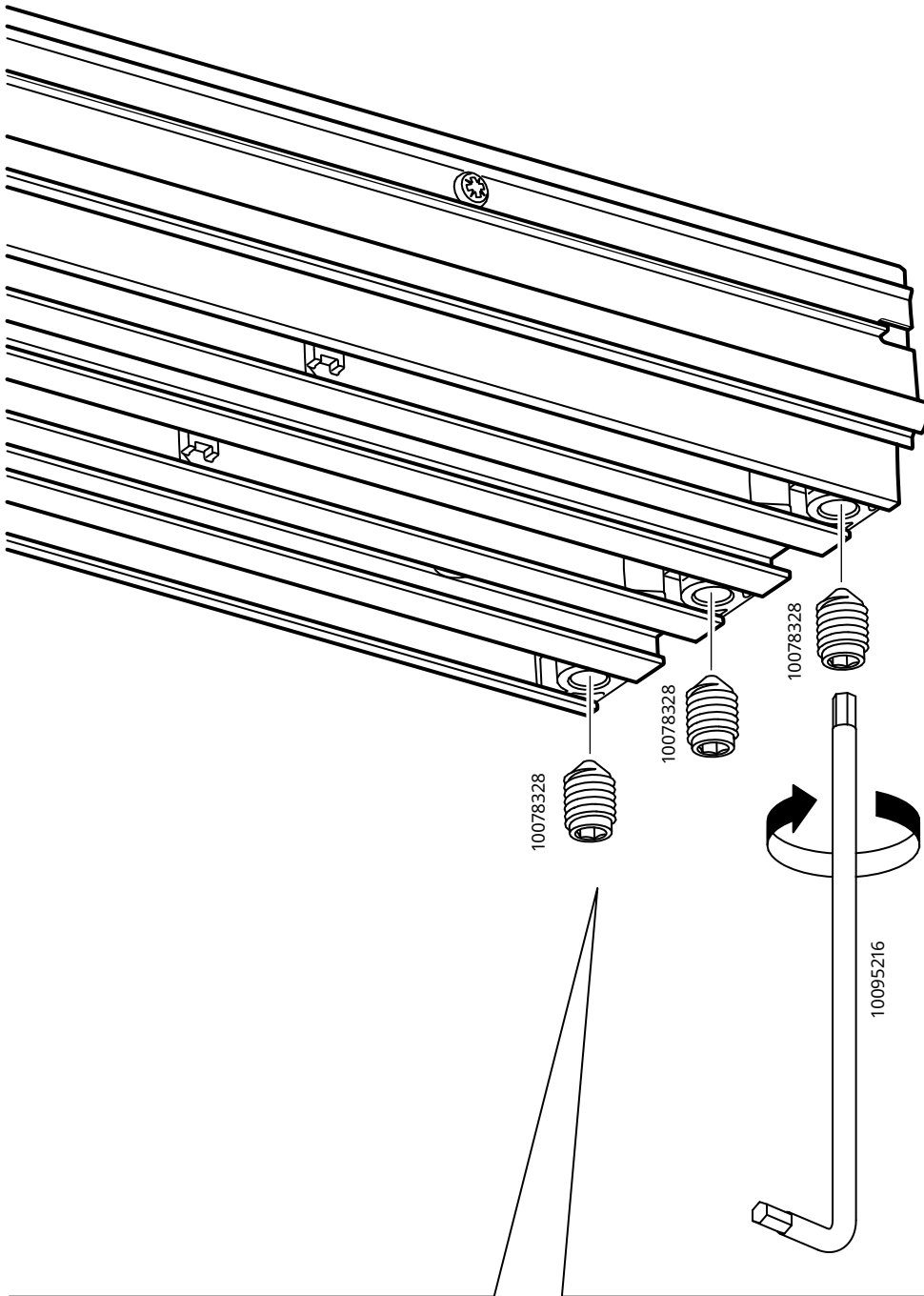

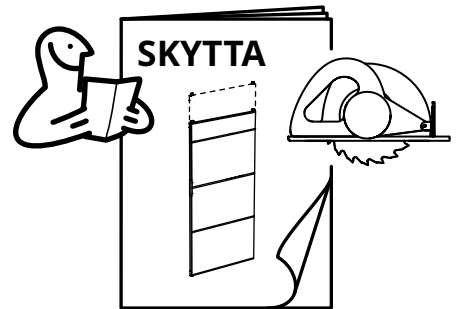
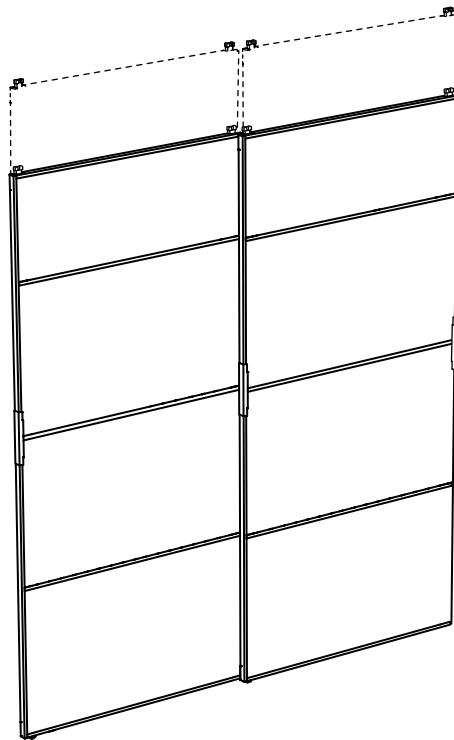
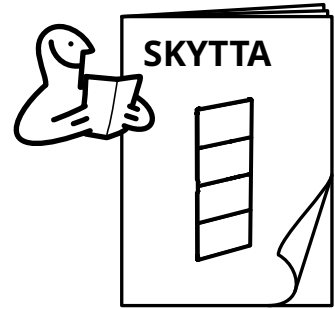
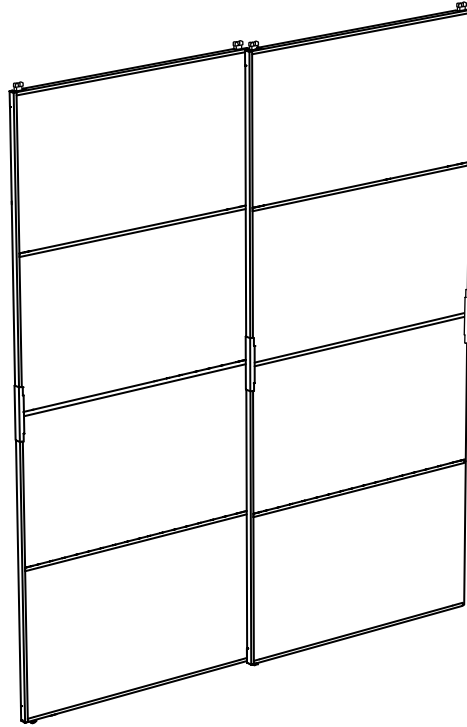

www.IKEA.com

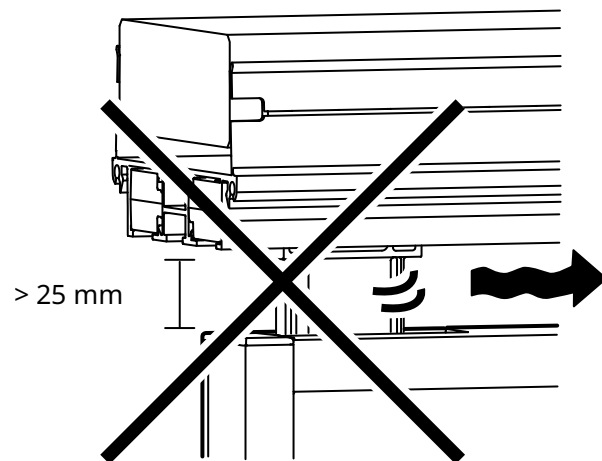
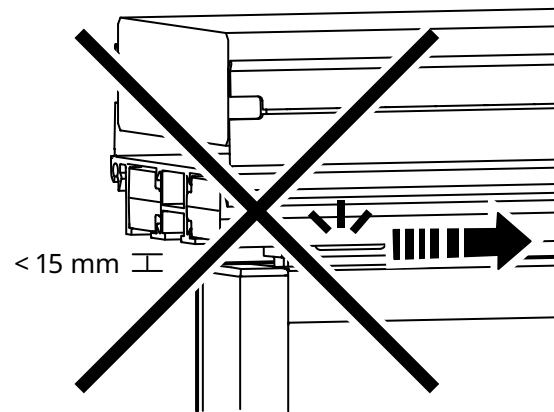
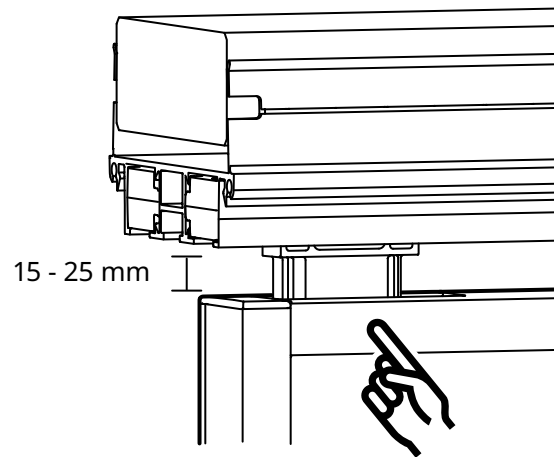

37

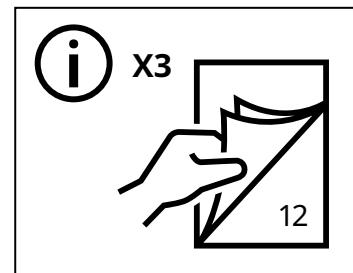
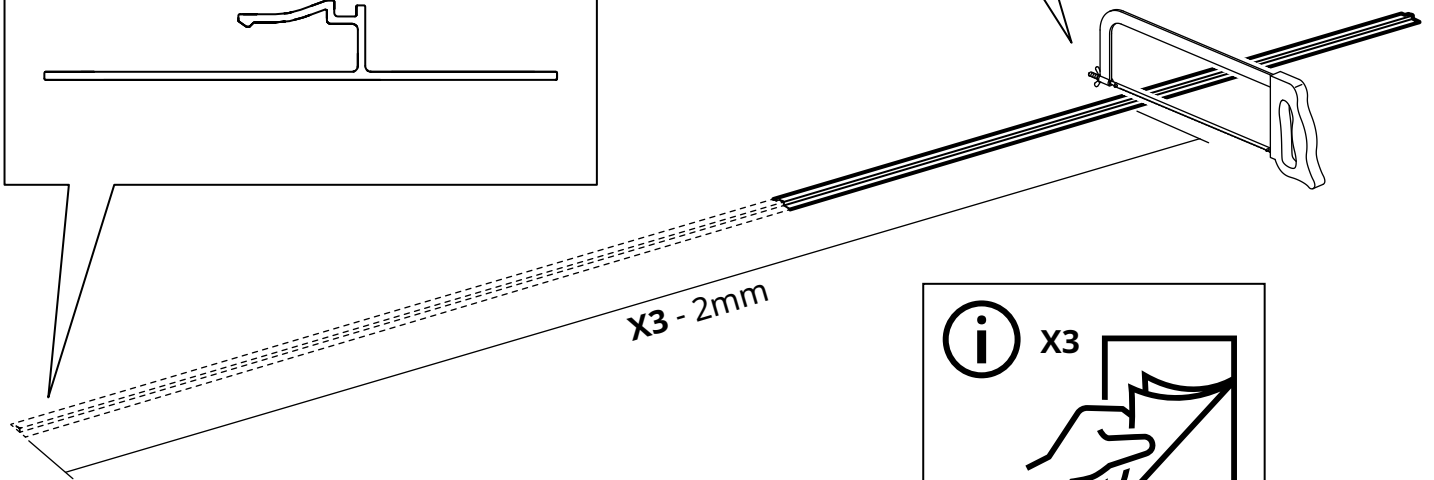
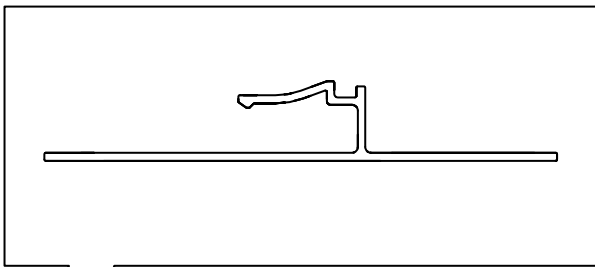
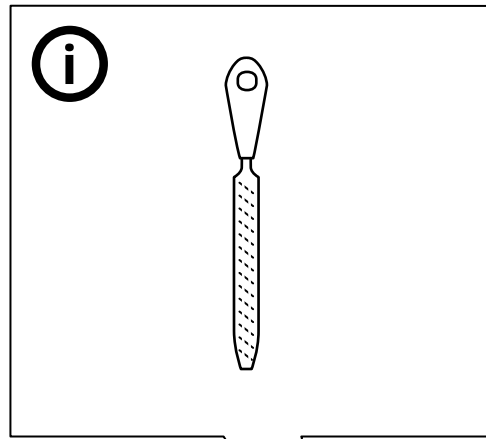

38

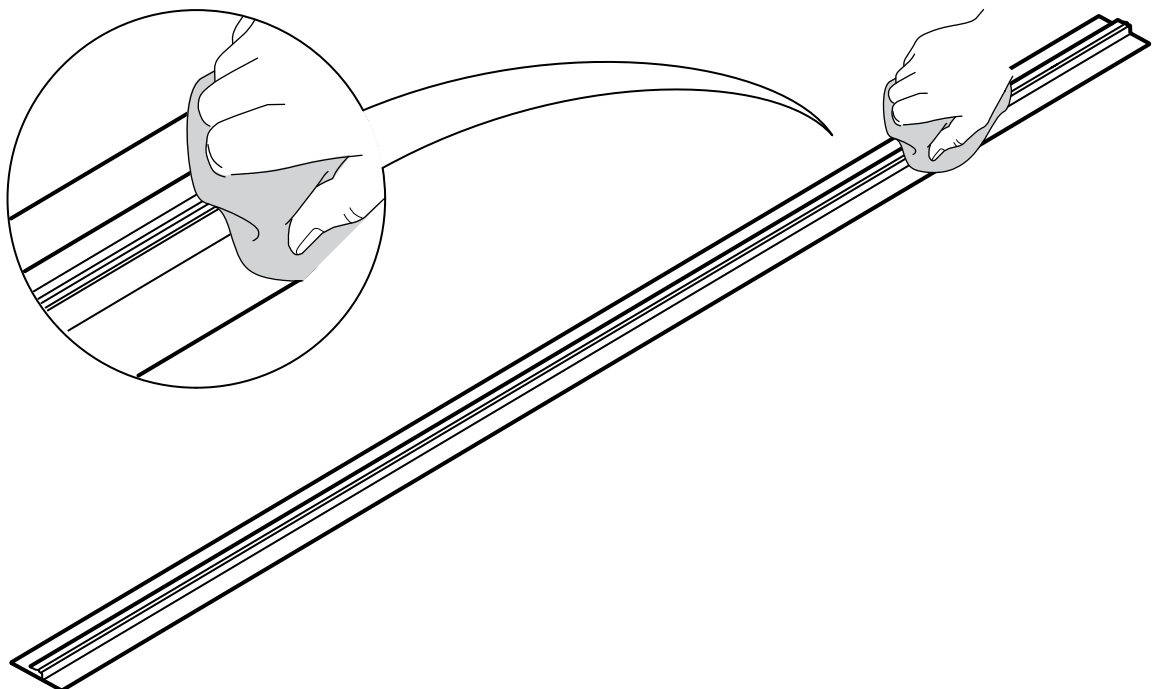

39

