

# SLADDA

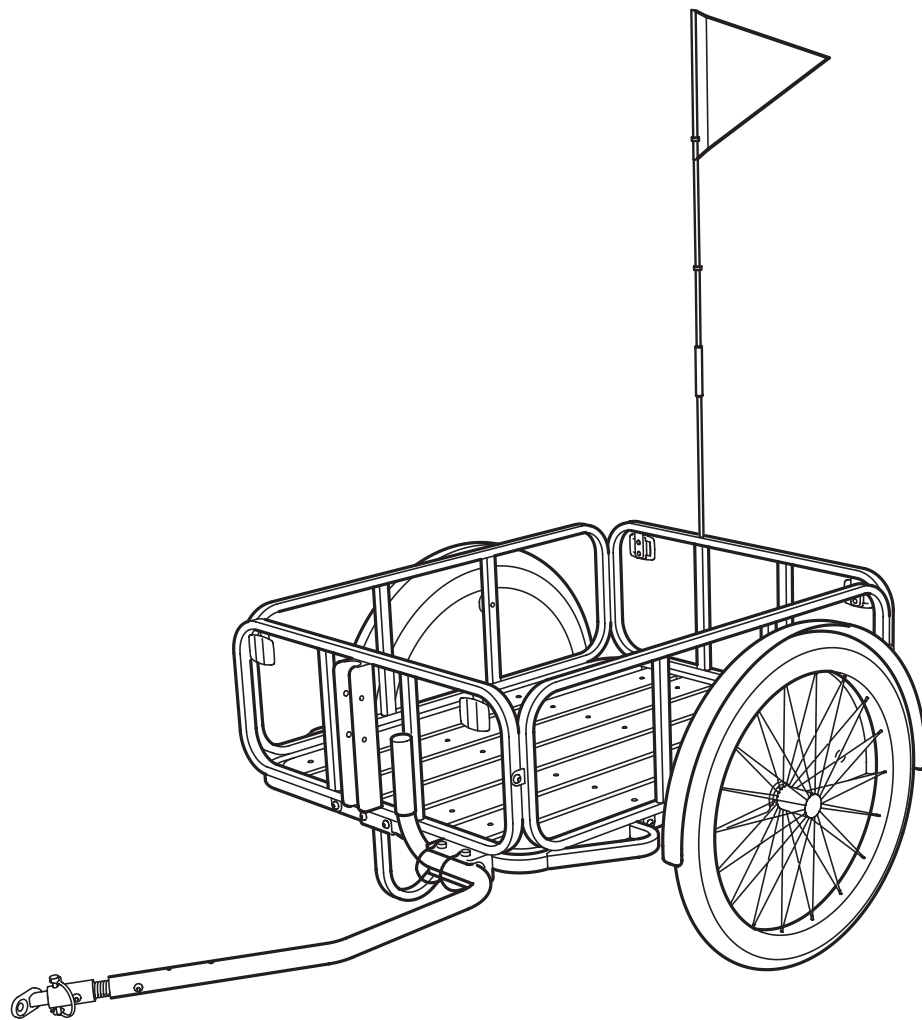

Design and Quality  
IKEA of Sweden



<b>ENGLISH</b>	<b>4</b>
<b>DEUTSCH</b>	<b>13</b>
<b>FRANÇAIS</b>	<b>22</b>
<b>NEDERLANDS</b>	<b>31</b>
<b>ESPAÑOL</b>	<b>40</b>
<b>ITALIANO</b>	<b>58</b>
<b>PORTUGUESE</b>	<b>70</b>

# ENGLISH

## CONTENTS

1. WARNING	4
2. SAFETY	4
3. CARE AND MAINTENANCE	4
4. TRAILER PARTS & COMPONENTS	5
5. ASSEMBLE YOUR TRAILER	6
6. TEST YOUR TRAILER	12

## 1. WARNING



- **Warning!** Your braking distance will increase when biking with a trailer.
- Fits SLADDA bicycle 26" and 28".
- **NOTE!** If you want to use this trailer with a different bicycle, make sure to check the bicycle manual for suitable fittings and trailers. Please note! Never connect the trailer to a mountain bike, racing bike, e-bike or any other bicycle that has motor assistance.
- SLADDA trailer is not suitable for transporting children or animals. Follow the manual to assemble and use the trailer in a correct and safe way.

## 2. SAFETY

For your own safety, always follow the traffic rules in your country.

## 3. CARE AND MAINTENANCE

Make sure to check the trailer components, such as assembly screws, fittings, frame, reflective and tyres regularly.

**IKEA of Sweden AB**  
34381 Älmhult  
Sweden

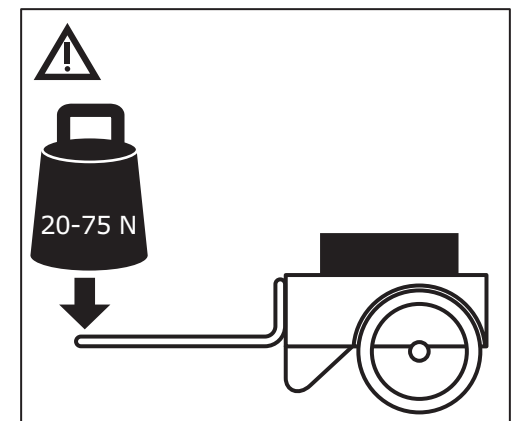
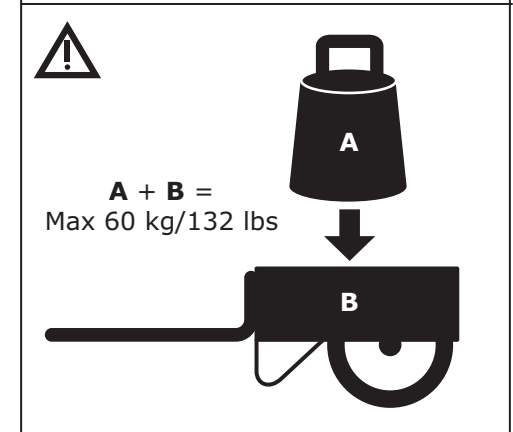
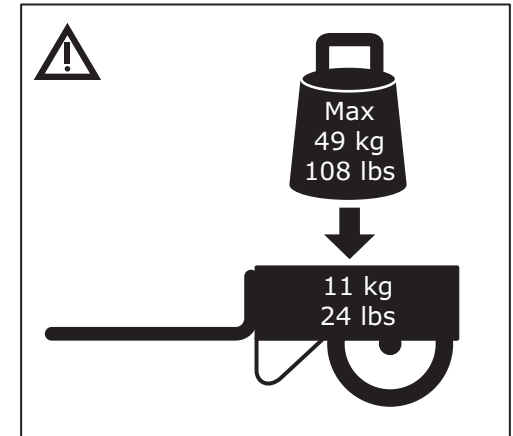

#### 4. TRAILER PARTS & COMPONENTS

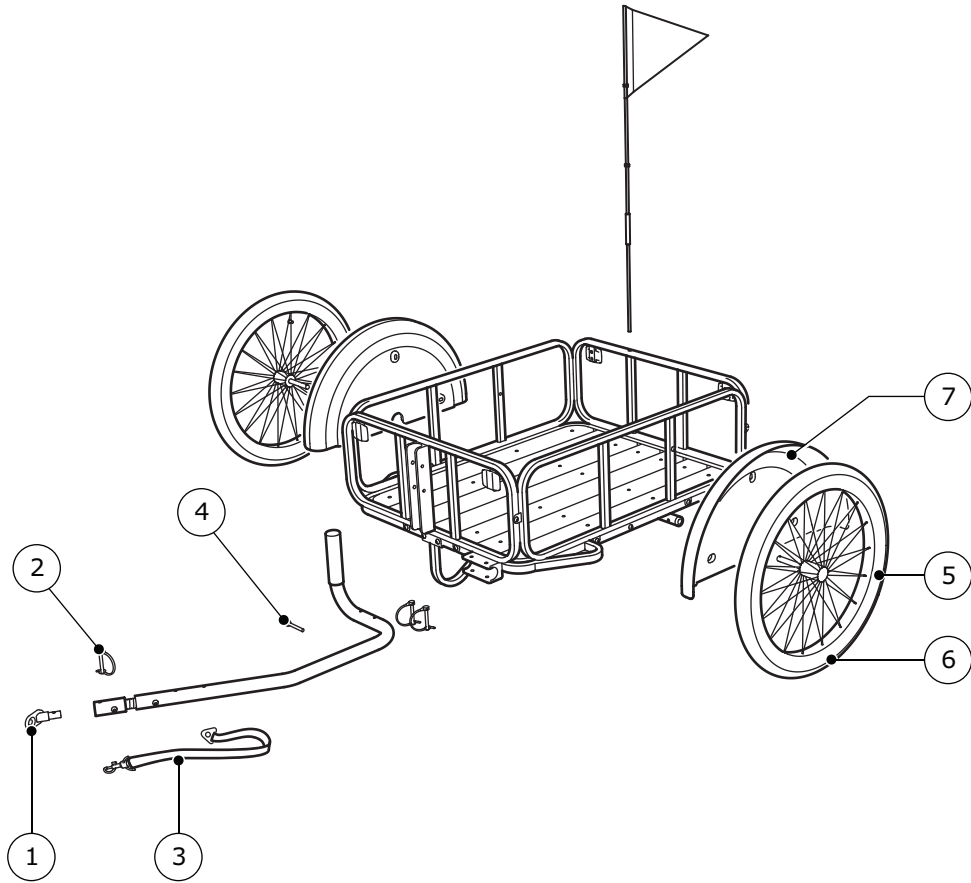

- 1 Connector (152921)
- 2 D-shape locker (152922)
- 3 Safety strap (152923)
- 4 M5 Screw (152924)
- 5 Tire, inner tube (152925)
- 6 Tire (152926)
- 7 Fender (152927)

## 5. ASSEMBLE YOUR TRAILER

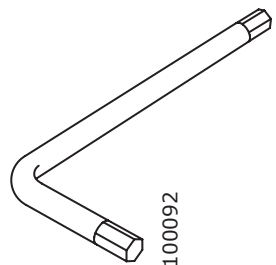
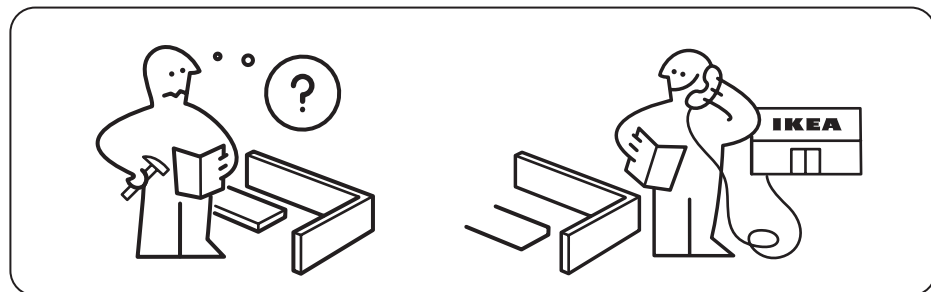
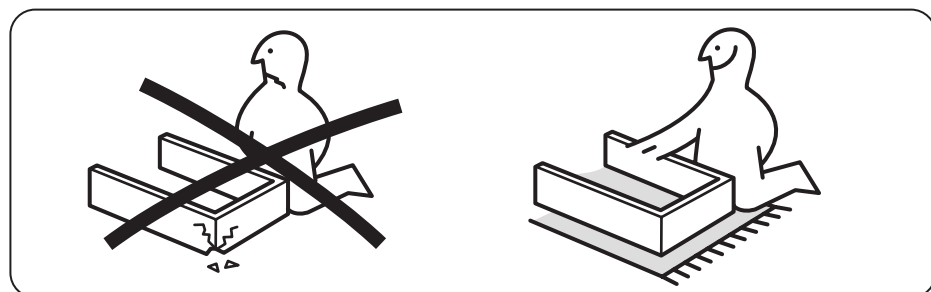
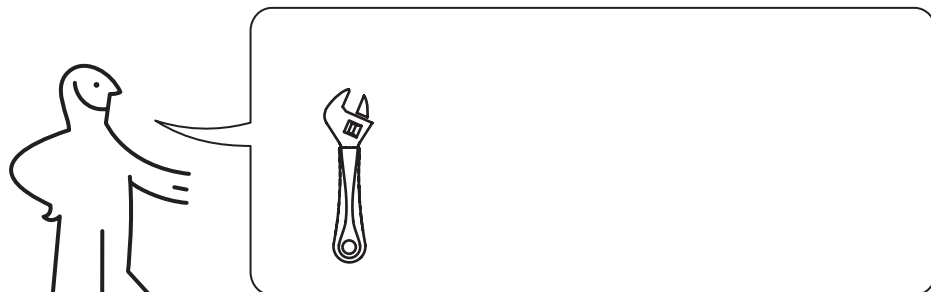

100092

1x

6

1

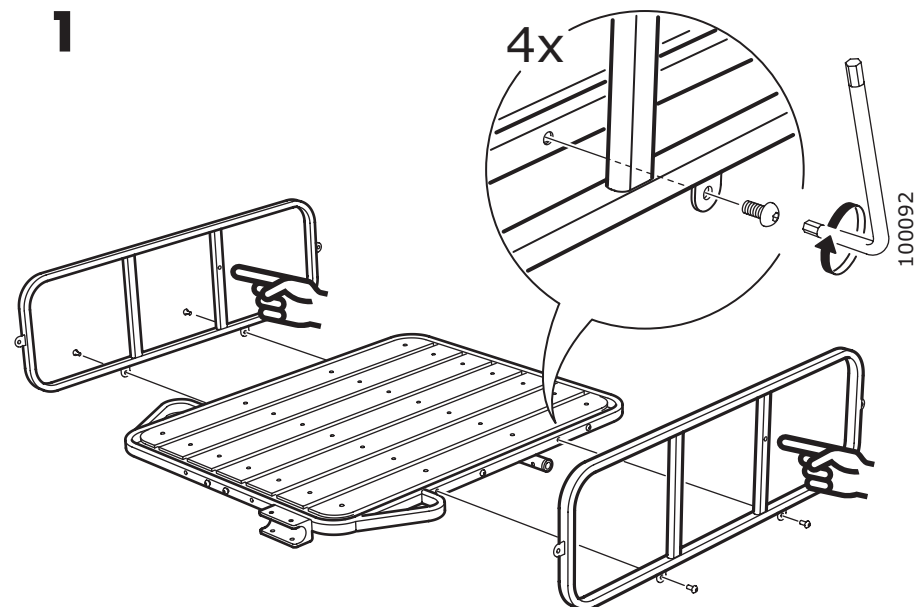

2

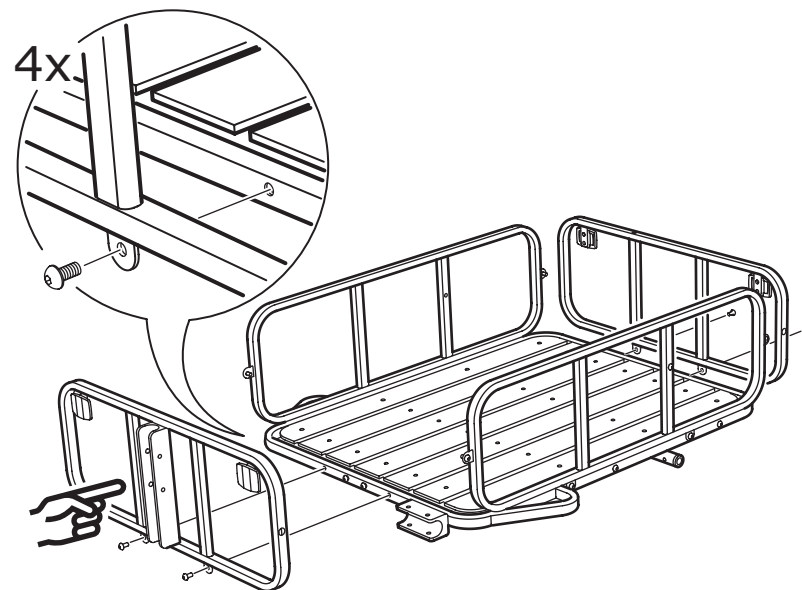

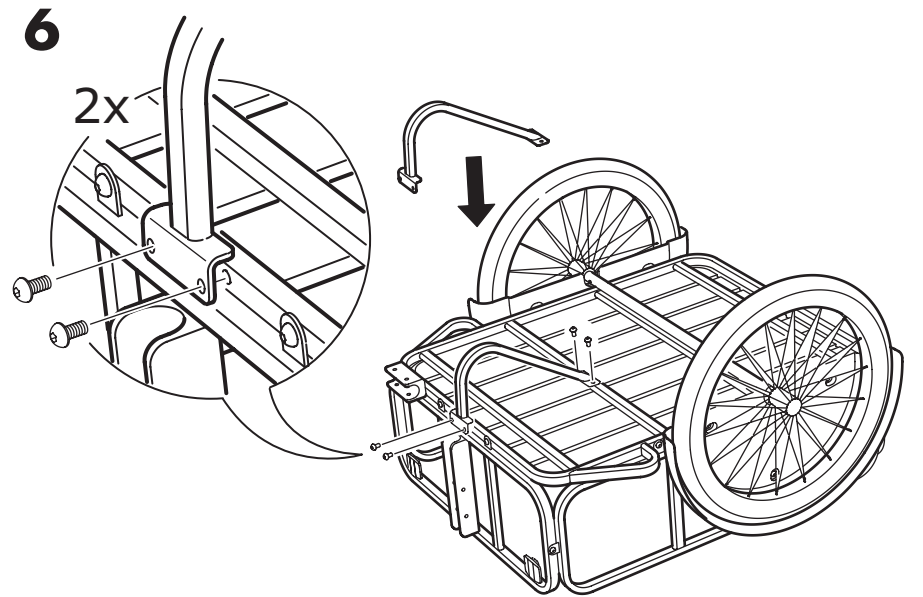
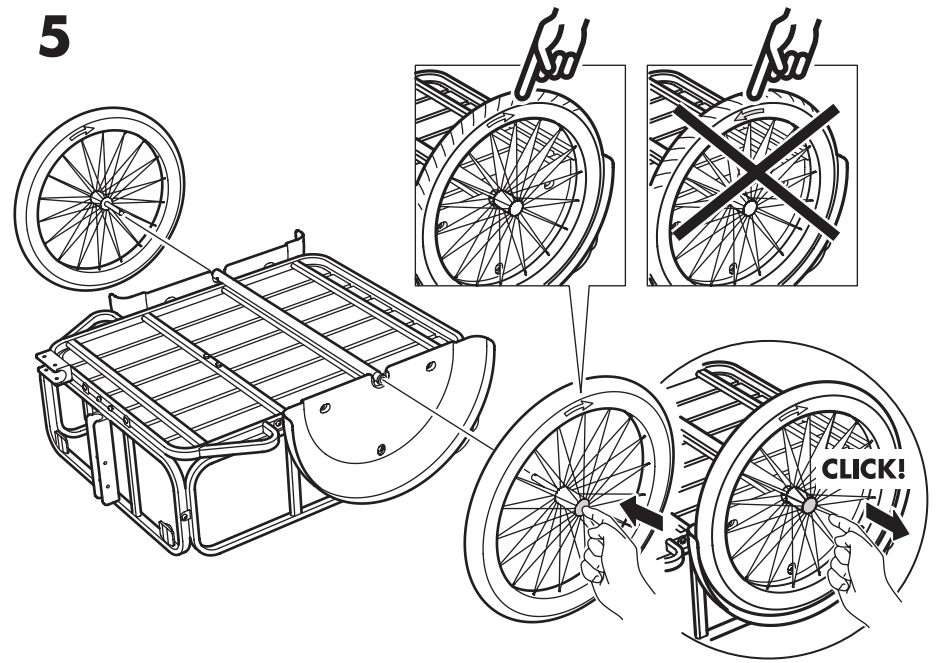
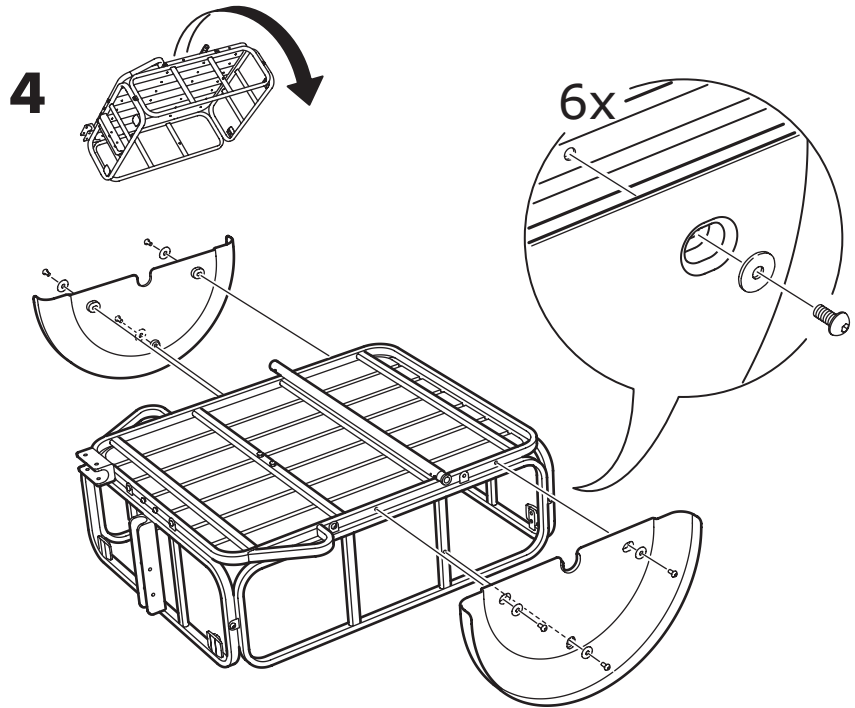
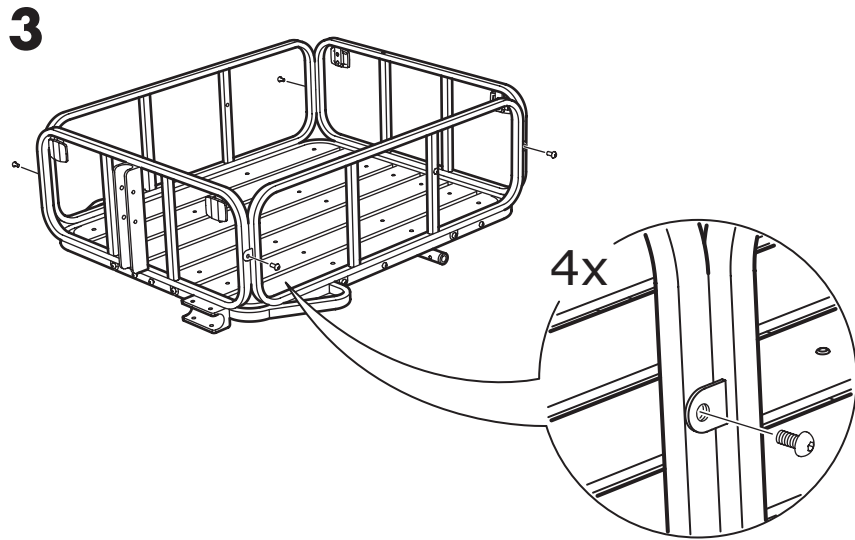

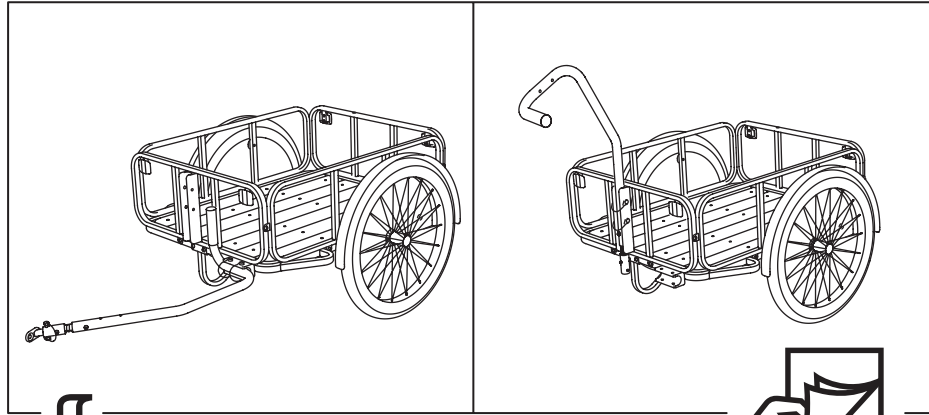

7

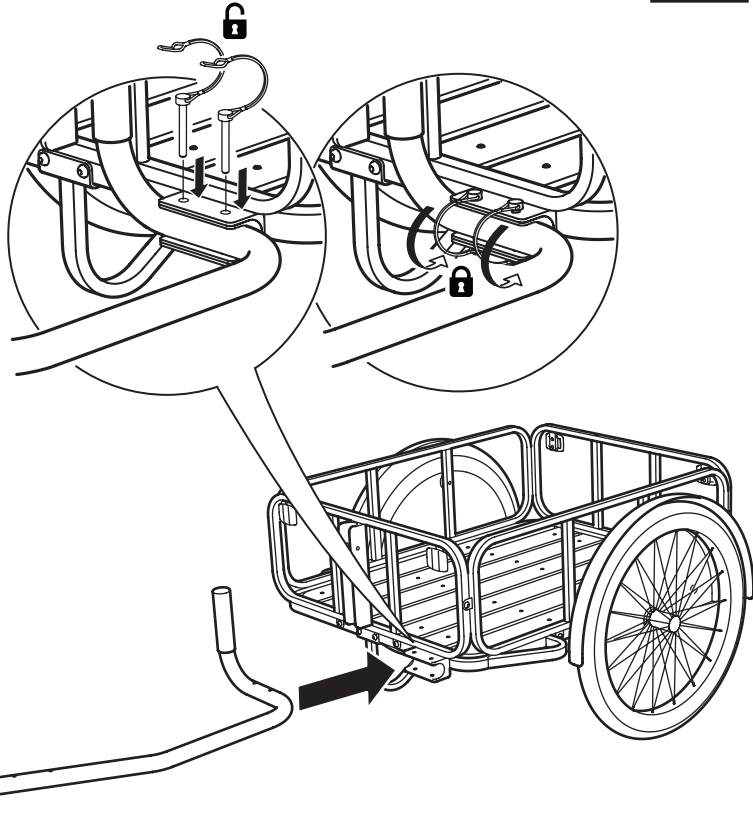

8

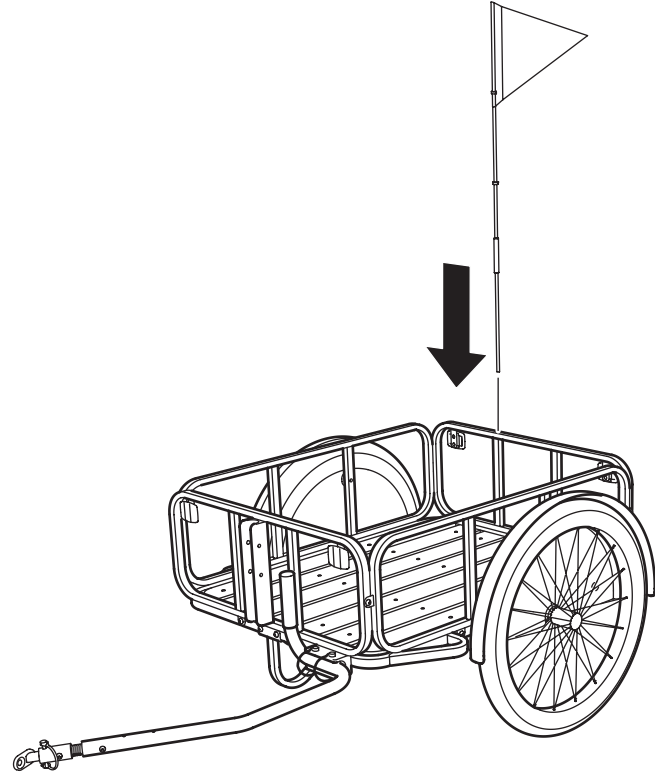



9

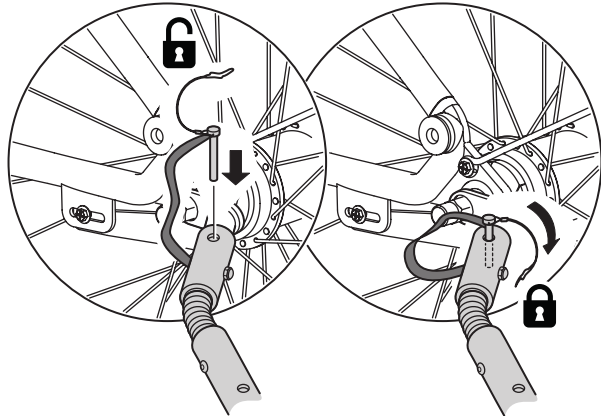
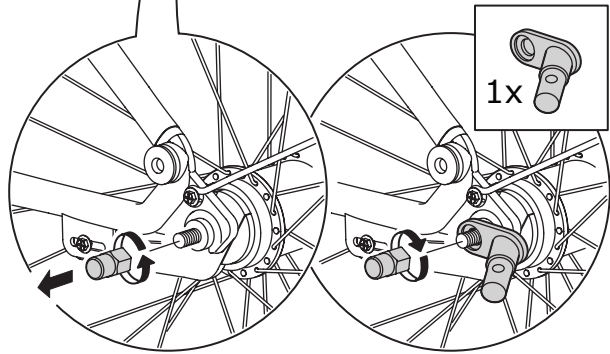
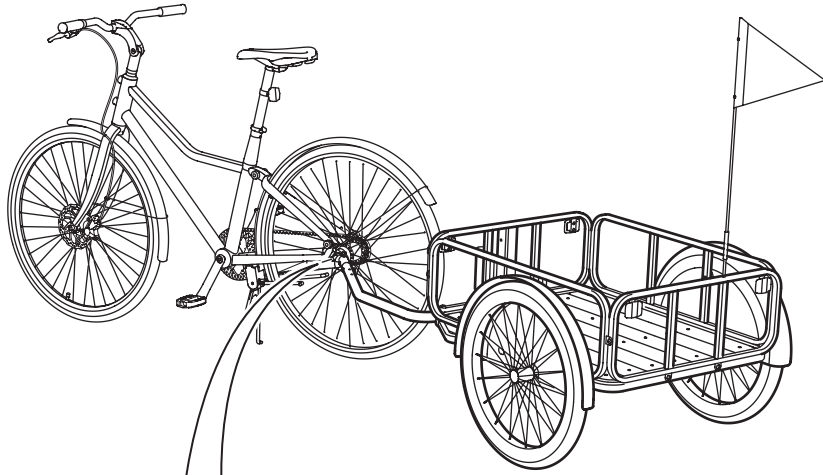

10

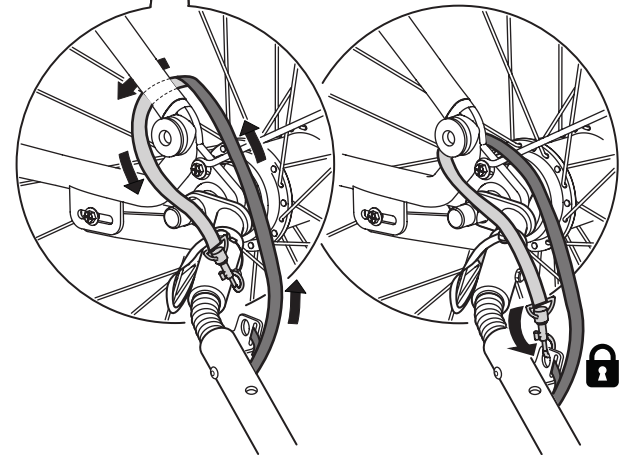
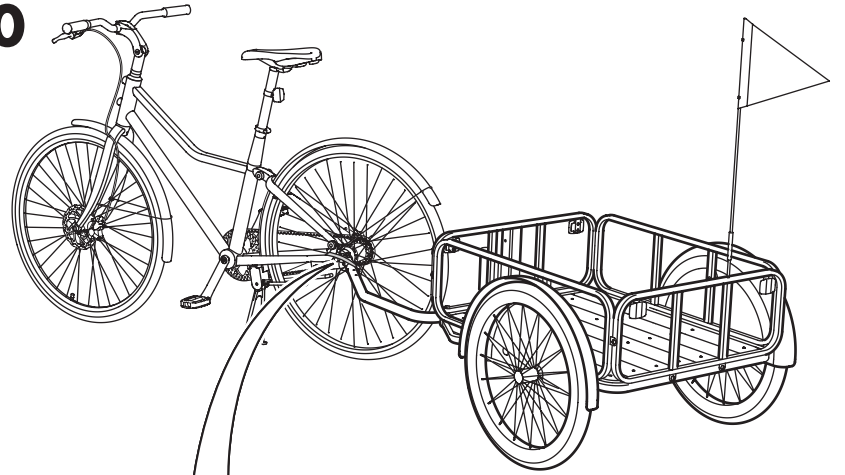

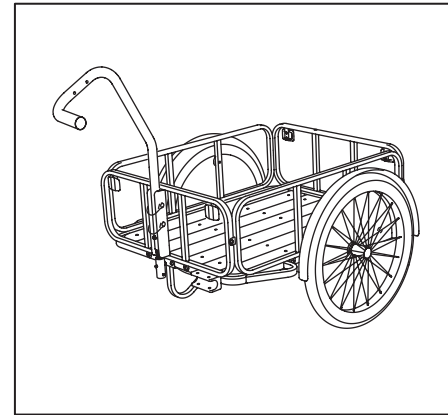
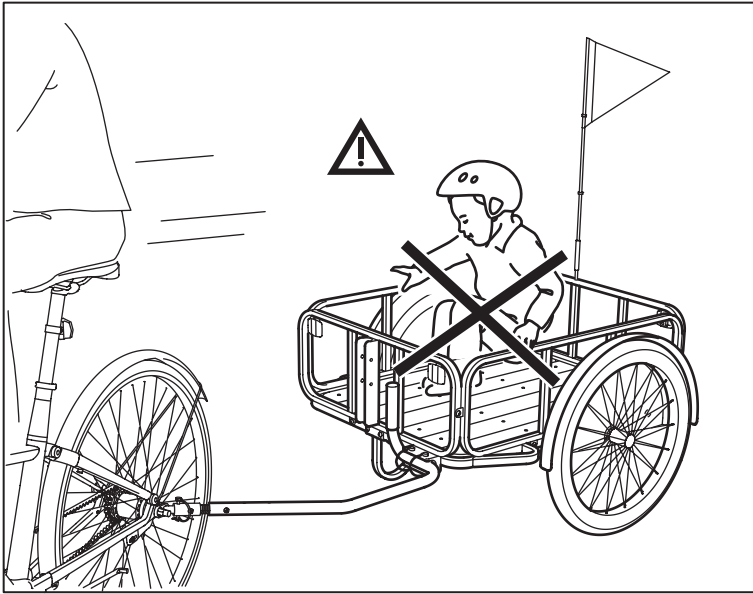

7

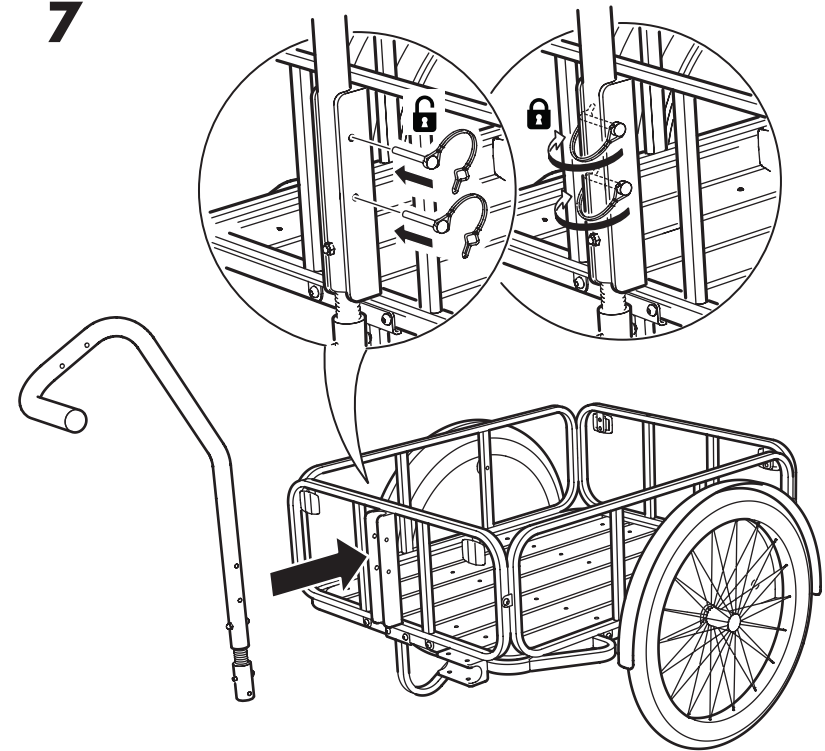

8

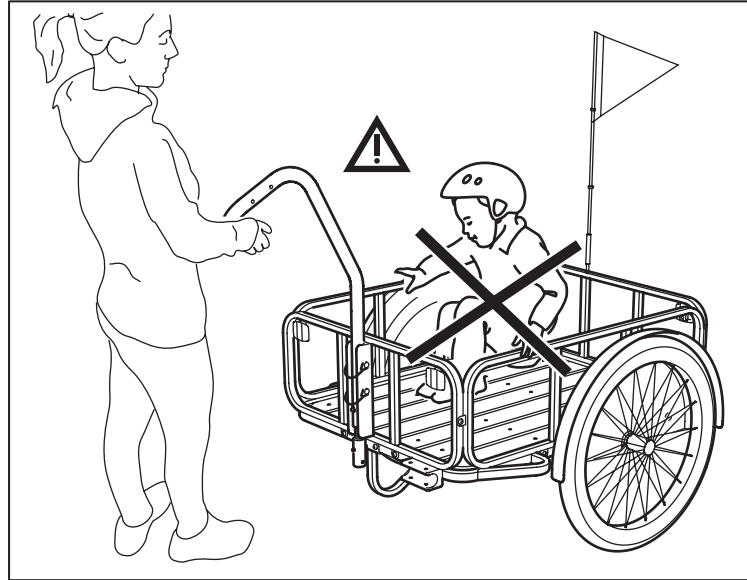
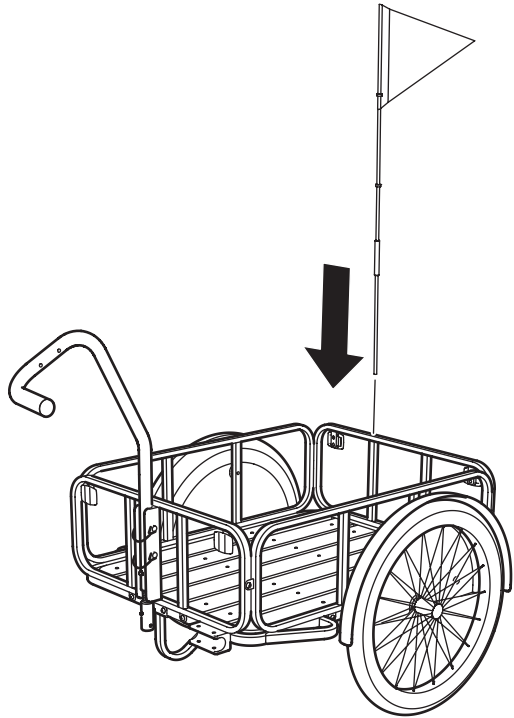

## 6. TEST YOUR TRAILER

Before using your trailer you should perform a safety check on level ground and away from heavy traffic. It is important that you ensure all parts are fastened and working properly.

### TEST THE TYRES

Make sure that the tyres are inflated to the recommended pressure limit using a tyre pump with a gauge. The pressure should not exceed the recommended limit as stated on the tyre. It is better to use a hand or foot pump rather than a service station pump as over inflation can cause the tyre to blow out.

### CHECK REFLECTORS

Check that reflectors are positioned correctly.



**WARNING:** *As with all mechanical components, the trailer is subjected to wear and high stress. Different materials and components may react to wear or stress fatigue in different ways. If the design life of a component has been exceeded, it may suddenly fail possibly causing injuries to the rider. Any form of cracks, scratches or change of colouring in highly stressed areas indicate that the life of the component has been reached and it should be replaced.*

# DEUTSCH

## INHALT

1. ACHTUNG	13
2. SICHERHEIT	13
3. WARTUNG UND UNTERHALT	13
4. TEILE & KOMPONENTEN	14
5. DEN ANHÄNGER MONTIEREN	15
6. ZUERST TESTEN	21

## 1. ACHTUNG



- **ACHTUNG!** Der Bremsweg ist länger, wenn man mit dem Anhänger am Rad fährt.
- Passend für SLADDA Fahrrad 26" und 28".
- **HINWEIS!** Wenn der Anhänger mit einem anderen Fahrrad benutzt werden soll, unbedingt im Handbuch des Fahrrads nachschlagen, ob der Anhängeschlag passt und welche Art von Anhänger zugelassen ist. Bitte beachten: den Anhänger keinesfalls an ein Mountainbike, Rennrad, Elektrofahrrad oder ein anderes Fahrrad mit Hilfsmotor ankuppeln.
- Der SLADDA Anhänger ist nicht geeignet für den Transport von Kindern oder Tieren. Für korrekte und sichere Montage und Benutzung des Anhängers die Angaben im Handbuch befolgen.

## 2. SICHERHEIT

Zur eigenen Sicherheit immer die geltenden Verkehrsregeln beachten.

## 3. WARTUNG UND UNTERHALT

Regelmäßig die Anhängerteile wie Montageschrauben, Befestigungsbeschläge, Rahmen, Reflektoren und Reifen überprüfen.

**IKEA of Sweden AB**  
34381 Älmhult  
Sweden

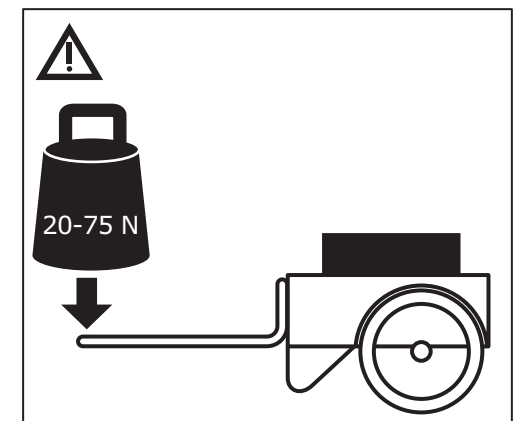
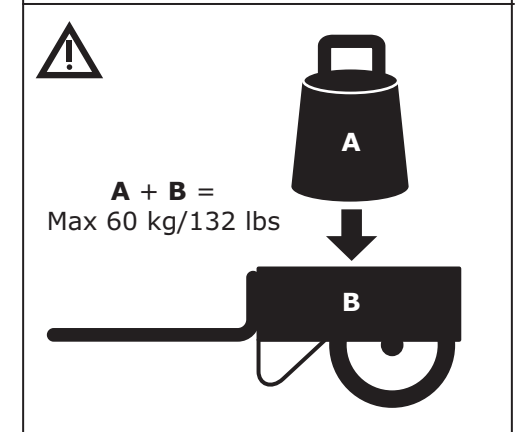
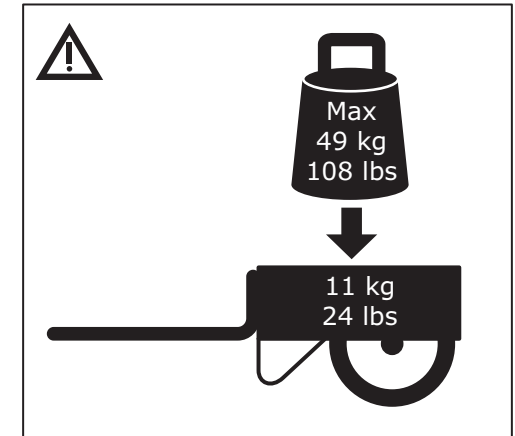

#### 4. TEILE & KOMPONENTEN

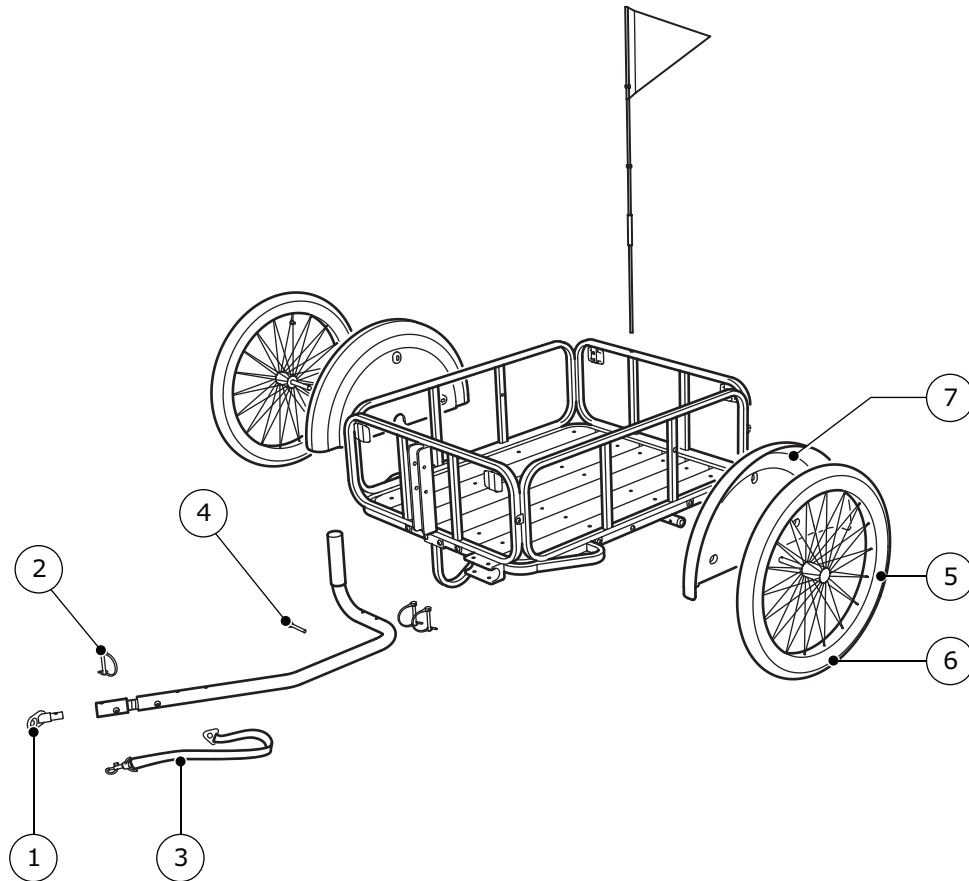

- 1 Kupplung (152921)
- 2 Schloss (152922)
- 3 Sicherungsgurt (152923)
- 4 M5-Schraube (152924)
- 5 Rad (Reifen & Schlauch) (152925)
- 6 Reifen (152926)
- 7 Schmutzfänger (152927)

## 5. DEN ANHÄNGER MONTIEREN

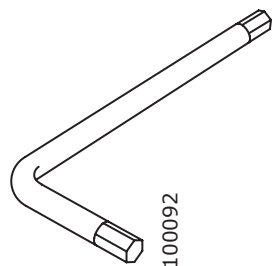
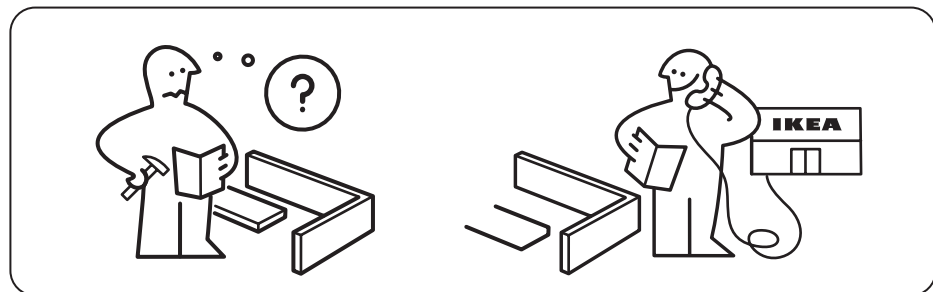
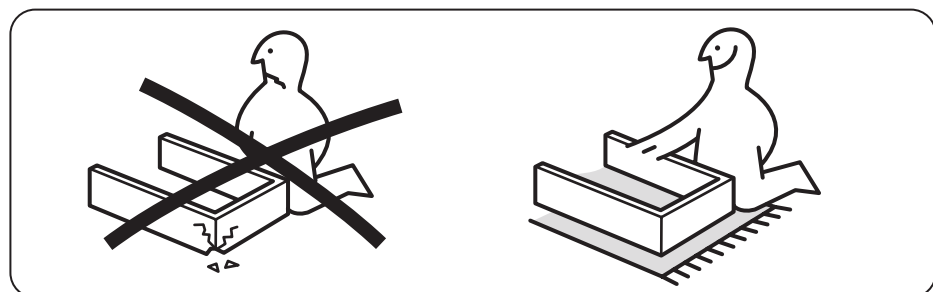
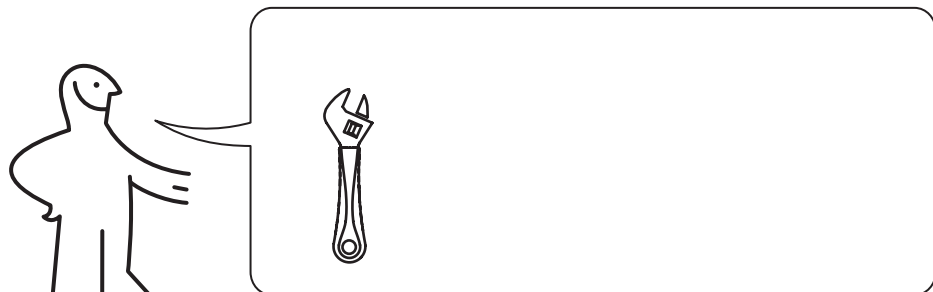

1x

100092

1

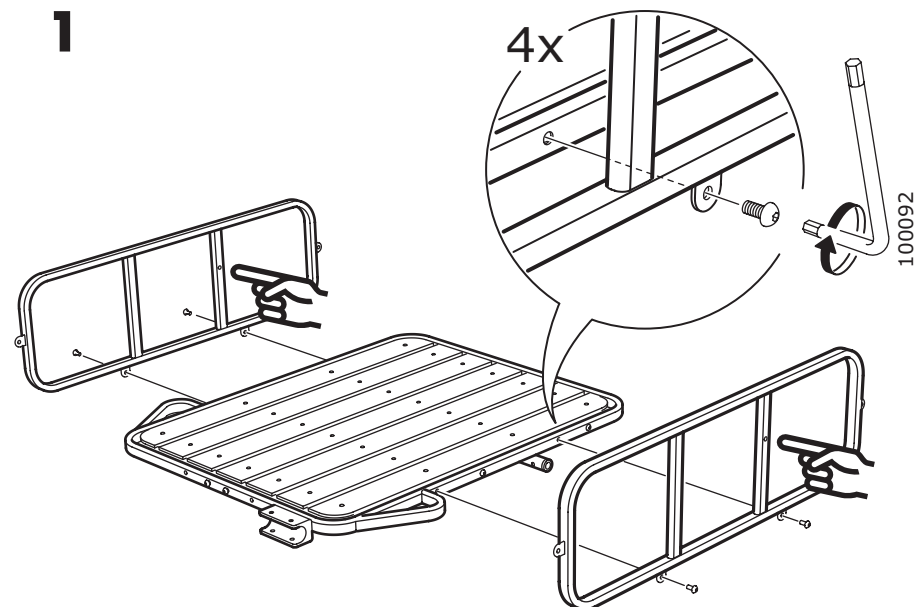

2

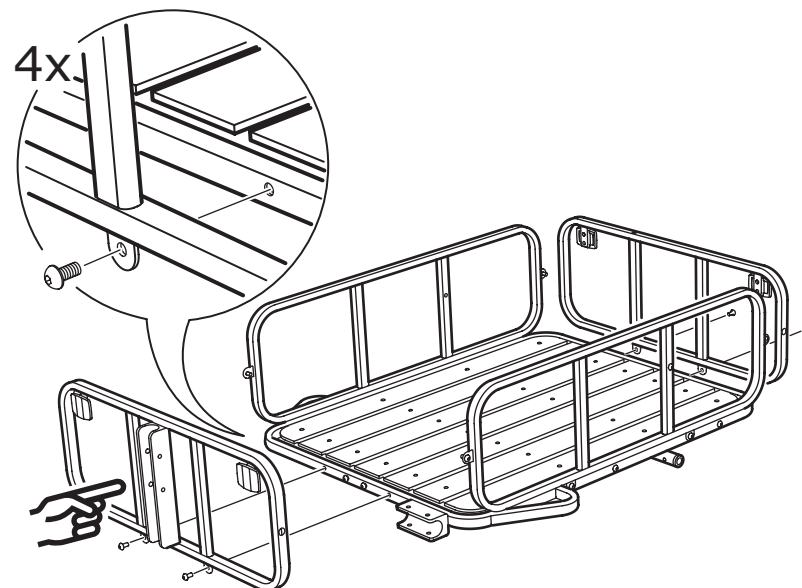

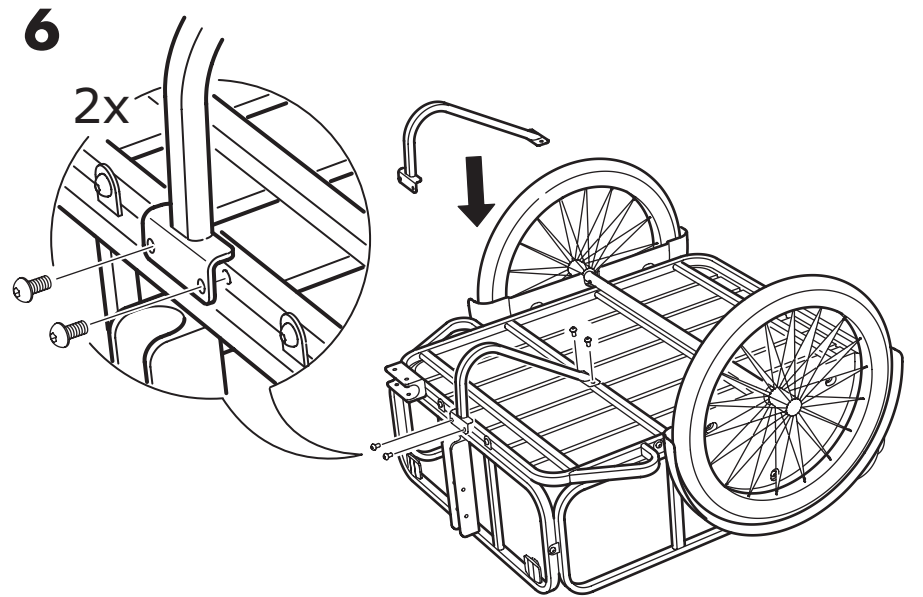
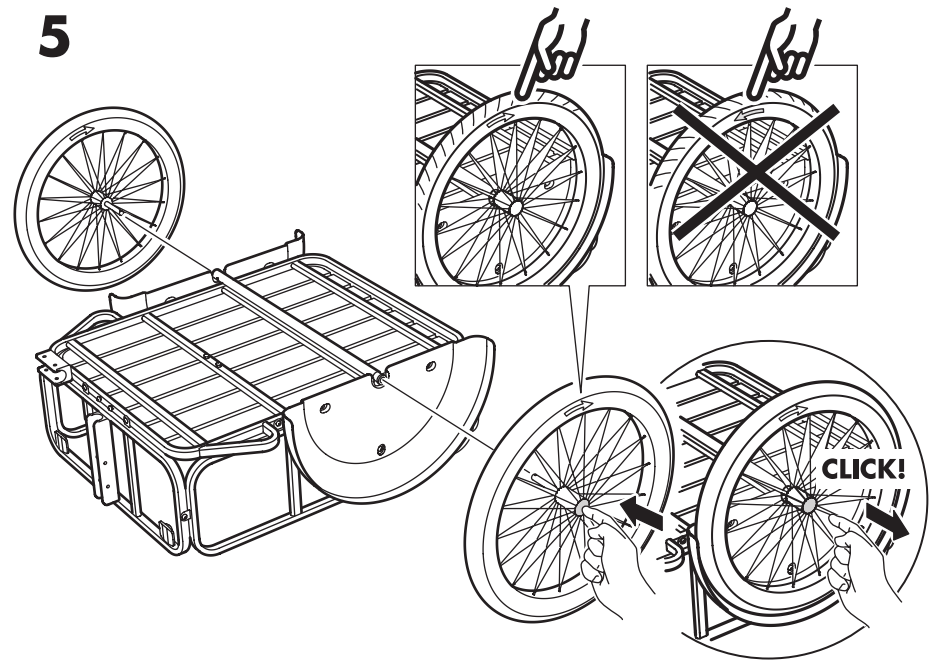
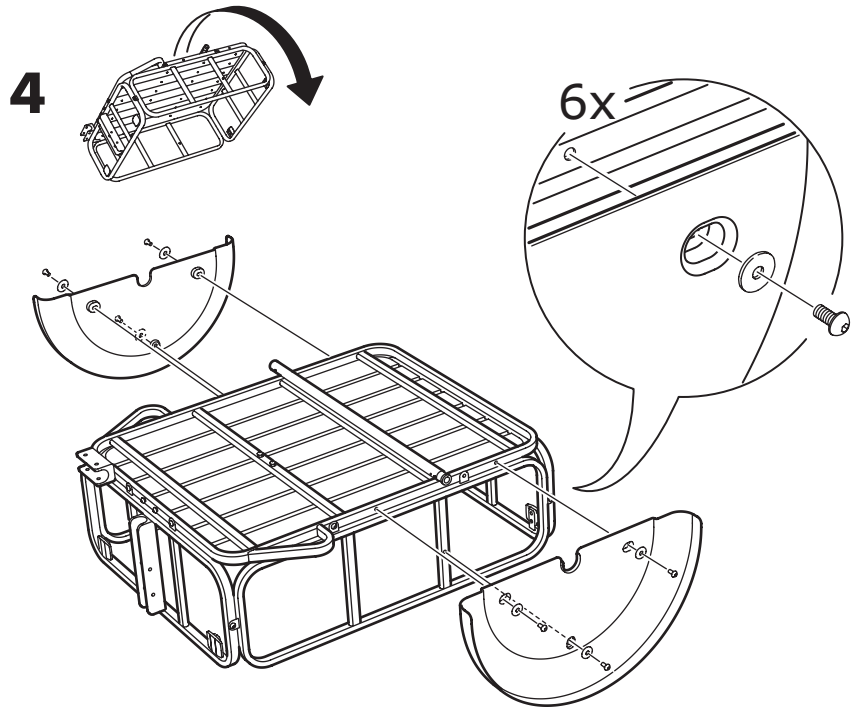
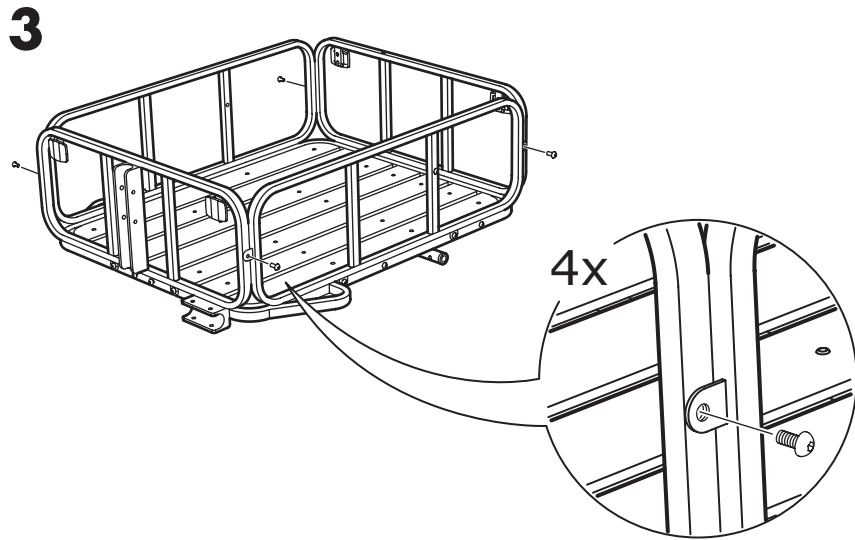



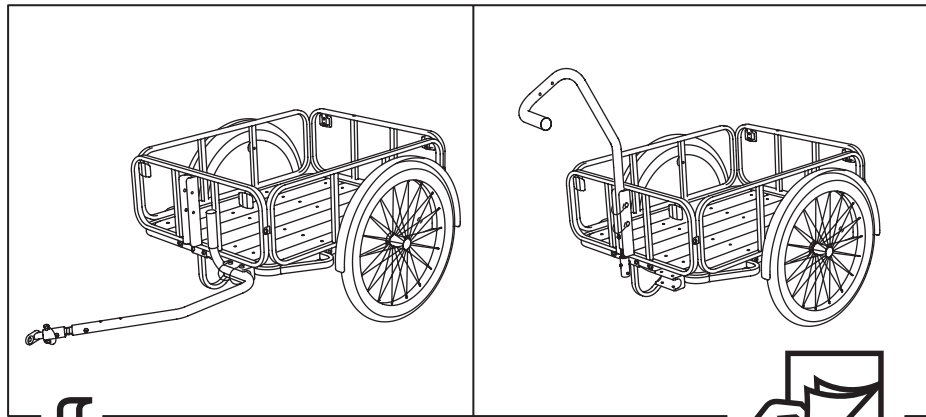

7

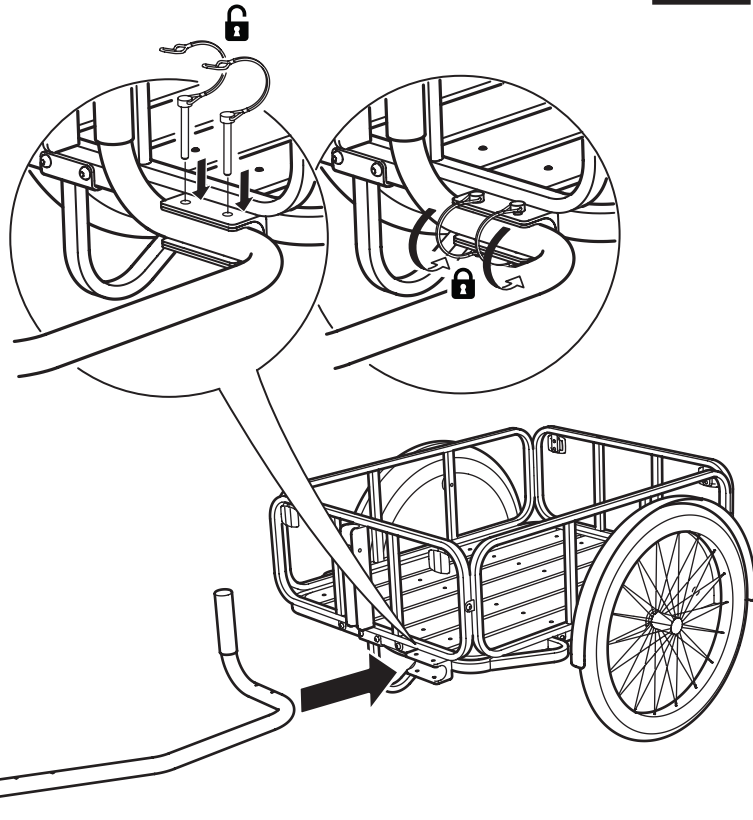

8

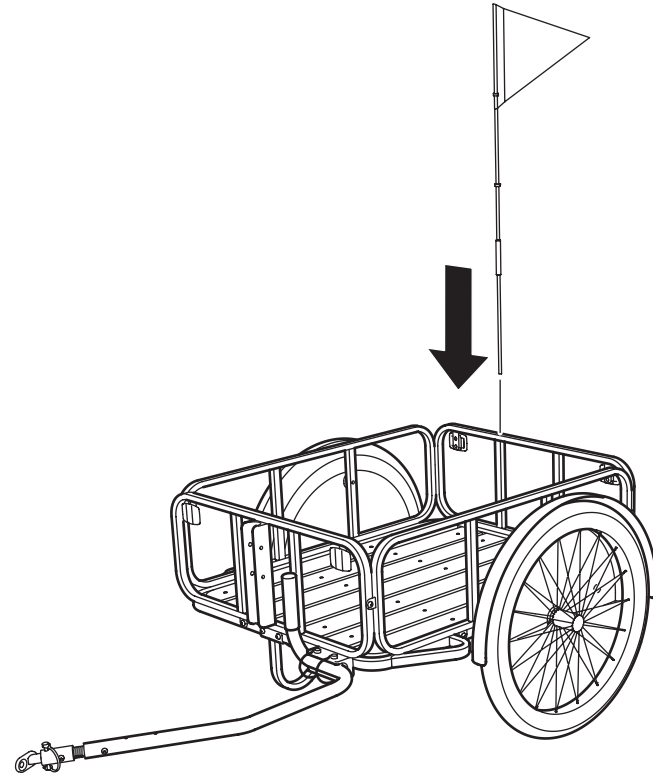

9

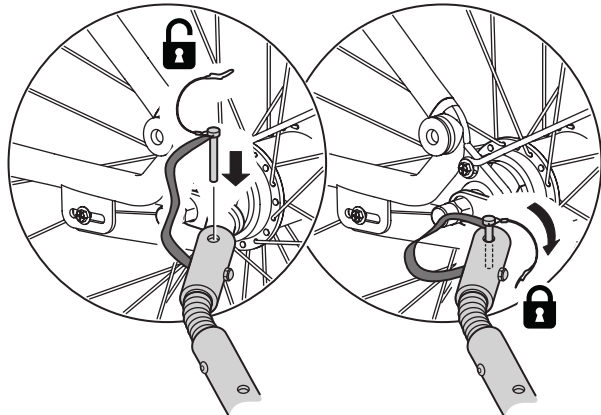
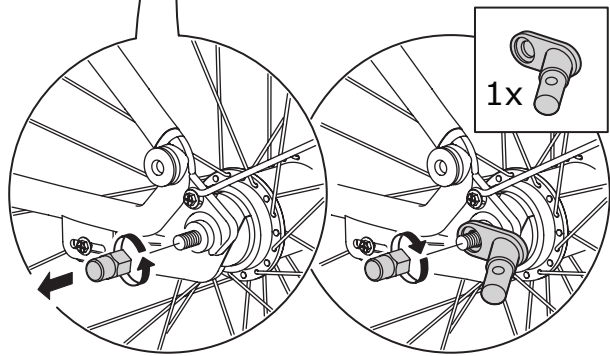
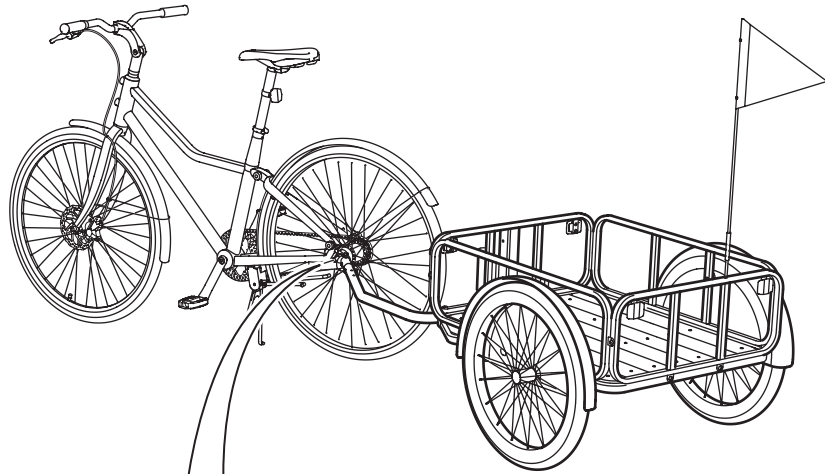

10

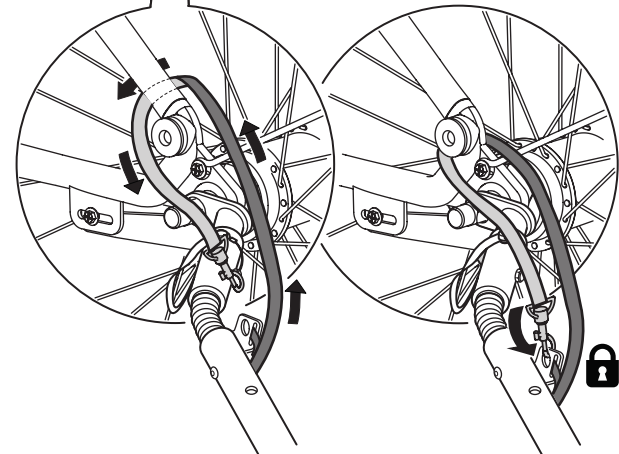
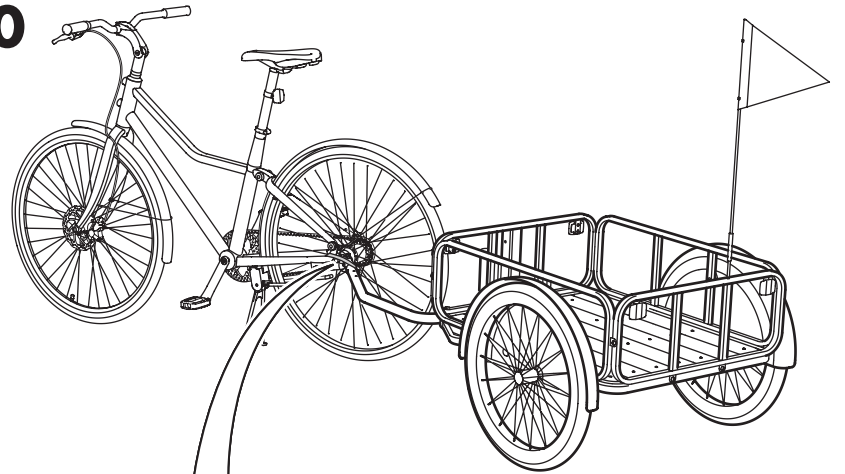

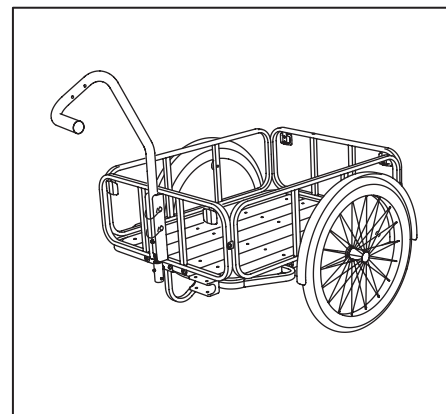
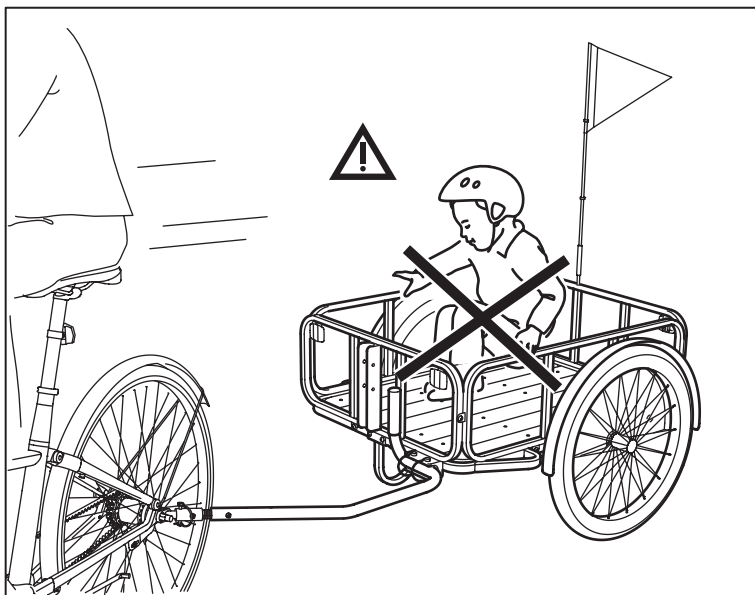

7

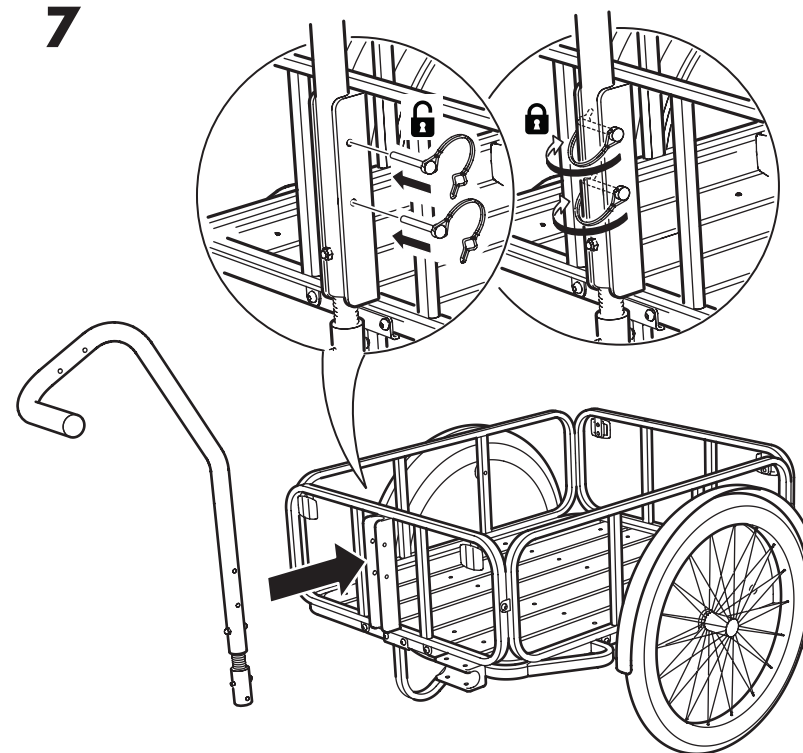

8

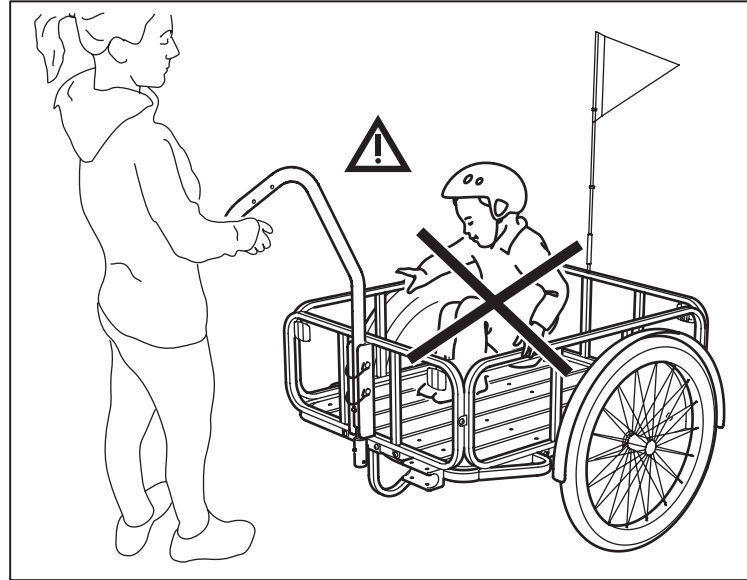
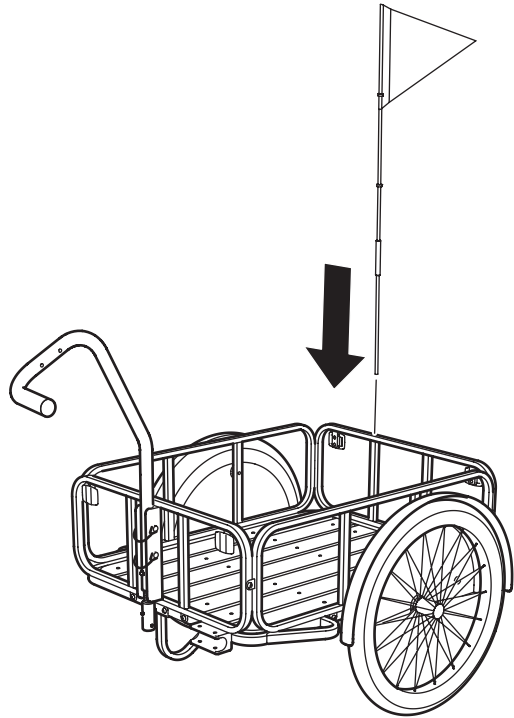

## 6. ZUERST TESTEN

Vor der Benutzung des Anhängers empfiehlt sich ein Sicherheitstest an einem Platz in ebener Lage mit wenig Verkehr. Es ist wichtig, dass alle Teile gut und sicher befestigt sind und ordnungsgemäß funktionieren.

### REIFEN TESTEN

Kontrollieren, ob die Reifen ausreichend aufgepumpt sind. Das geht am besten mit einer Luftpumpe mit Manometer. Der Druck soll die auf dem Reifen angegebene Grenze nicht überschreiten. Es ist besser, statt einer automatischen Pumpe eine Hand- oder Fußluftpumpe zu benutzen, da bei Überdruck der Reifen platzen könnte.

### REFLEKTOREN PRÜFEN

Kontrollieren, dass alle Reflektoren an der richtigen Stelle sitzen.



**ACHTUNG!** Wie alle anderen Produkte mit mechanischen Komponenten und Bauteilen ist auch ein Anhänger Verschleiß und Materialermüdung ausgesetzt. Material und Teile reagieren unterschiedlich auf hohe Beanspruchung. Wenn die ausgelegte Lebensdauer eines Bauteils überschritten ist, kann es plötzlich aufhören, zu funktionieren und der Benutzer des Produkts kann dadurch zu Schaden kommen. Risse, Sprünge oder Farbveränderungen in stark beanspruchten Bereichen können Warnzeichen sein, dass die Verschleißgrenze des Teils erreicht ist und es ausgetauscht werden muss.

## TABLE DES MATIÈRES

1. ATTENTION	22
2. SÉCURITÉ	22
3. NETTOYAGE ET ENTRETIEN	22
4. COMPOSANTS ET CARACTÉRISTIQUES	23
5. MONTAGE DE LA REMORQUE	24
6. VÉRIFIER LA REMORQUE AVANT UTILISATION	30

## 1. ATTENTION



- **Attention !** La distance de freinage augmente quand le vélo tracte une remorque.
- Convient aux vélos SLADDA 26" et 28".
- **REMARQUE !** Si vous voulez utiliser cette remorque avec un autre vélo, lisez le manuel de cet autre vélo pour vous assurer qu'il comporte les fixations nécessaires et qu'il peut tracter une remorque. Remarque importante ! Ne jamais accrocher la remorque à un VTT, un vélo de course, un vélo à assistance électrique ou un vélo avec moteur.
- La remorque SLADDA ne convient pas au transport des enfants ou des animaux. Suivre les instructions du manuel pour monter et utiliser correctement la remorque en toute sécurité.

## 2. SECURITE

Pour votre sécurité, toujours suivre les règles du code de la route en vigueur dans votre pays.

## 3. NETTOYAGE ET ENTRETIEN

Vérifiez régulièrement les éléments constitutifs de la remorque, vis de montage, fixations, structure, bandes réfléchissantes et pneus.

**IKEA of Sweden AB**  
34381 Älmhult  
Sweden

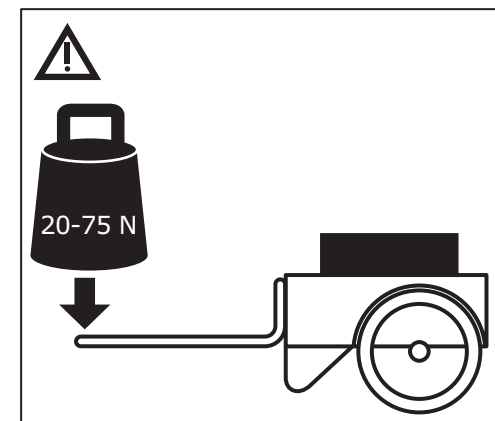
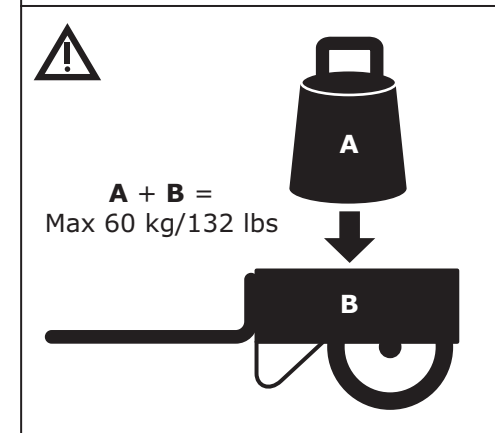
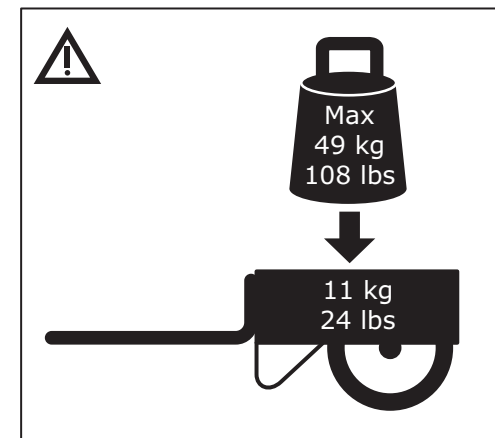

#### 4. COMPOSANTS ET CARACTÉRISTIQUES:

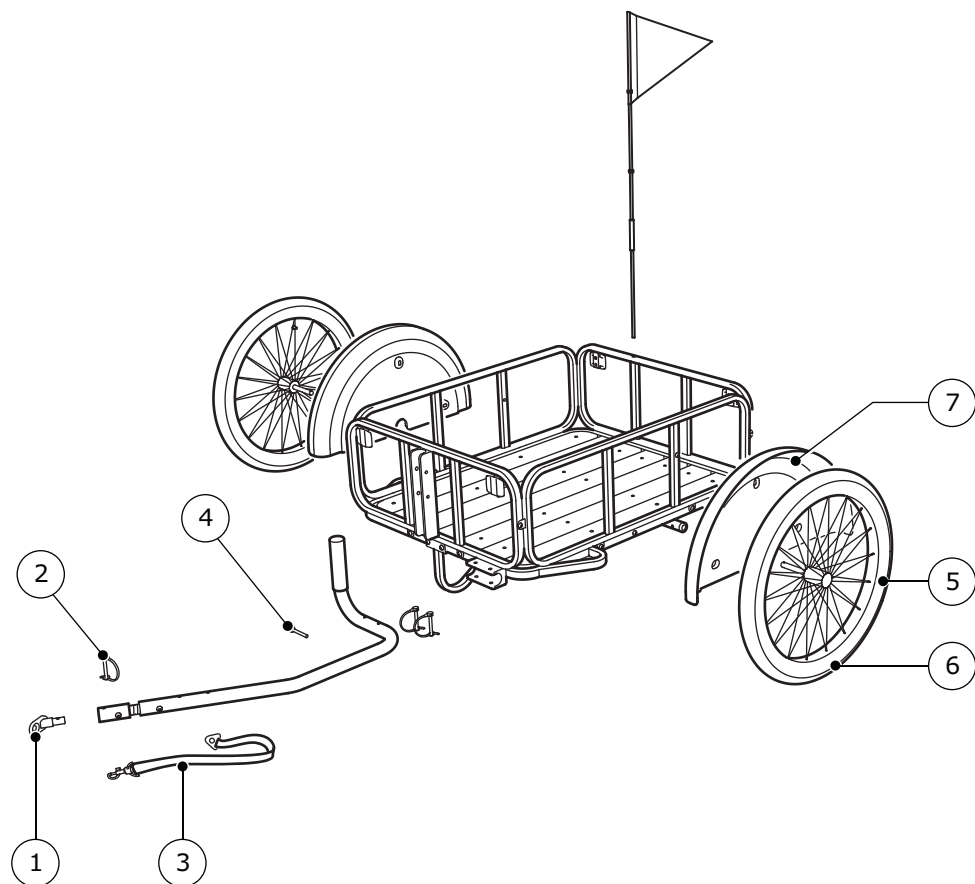

- 1 Pièce de raccordement (152921)
- 2 Mousqueton (152922)
- 3 Courroie de sécurité (152923)
- 4 Vis M5 (152924)
- 5 Pneu, chambre à air (152925)
- 6 Pneu (152926)
- 7 Garde-boue (152927)

## 5. MONTAGE DE LA REMORQUE

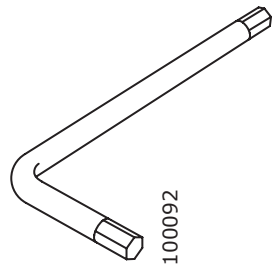
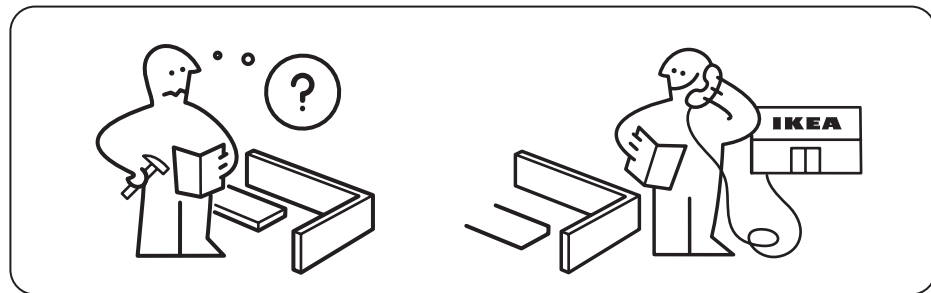
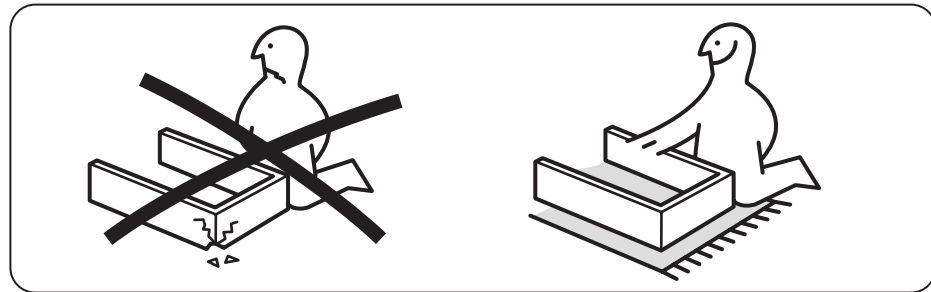
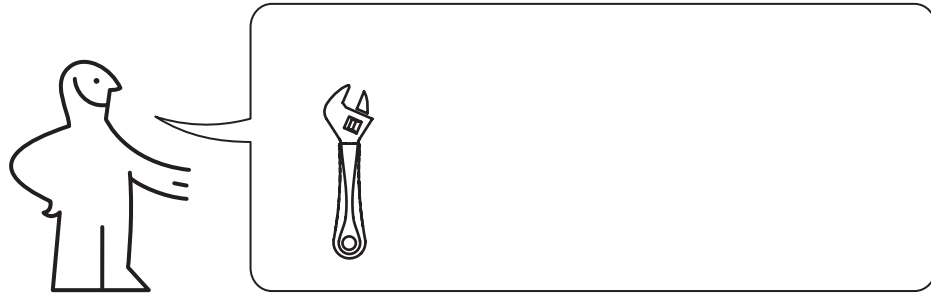

100092

1x

1

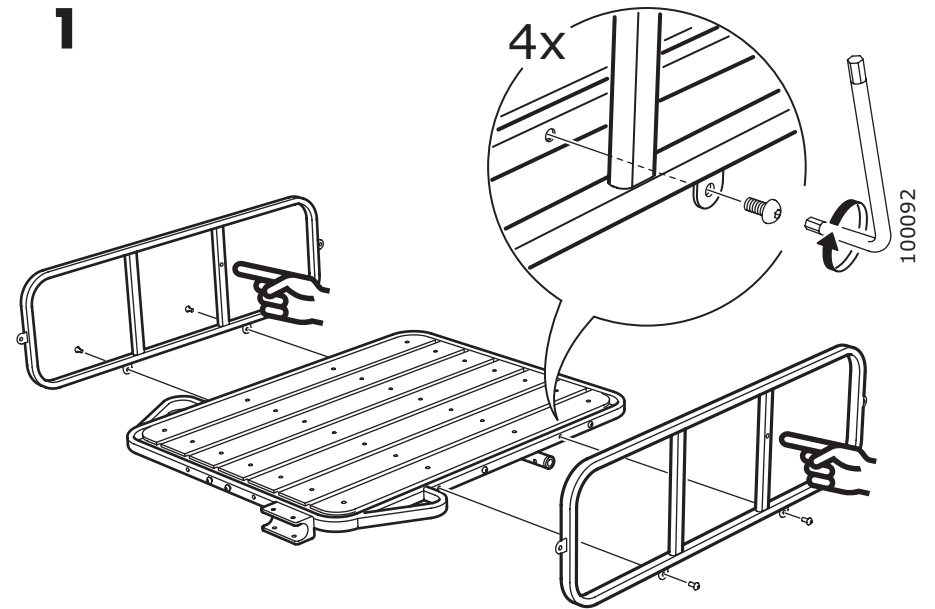

2

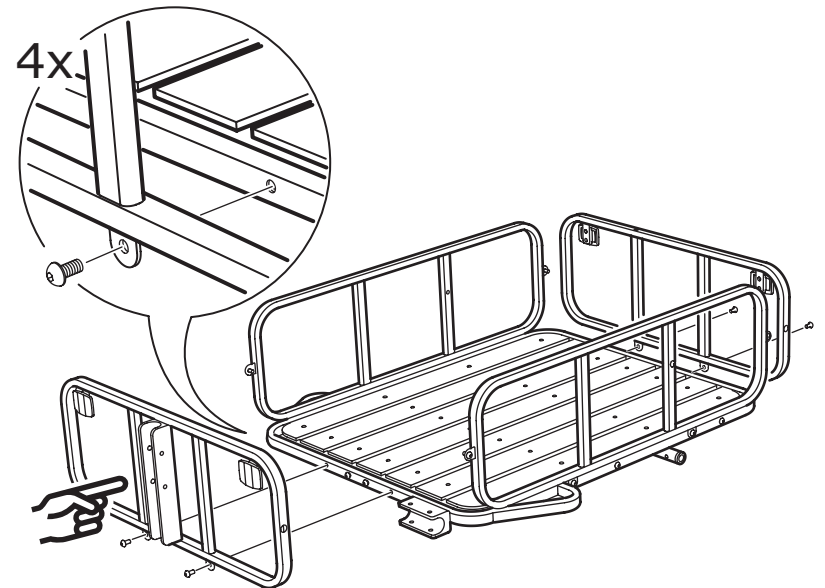



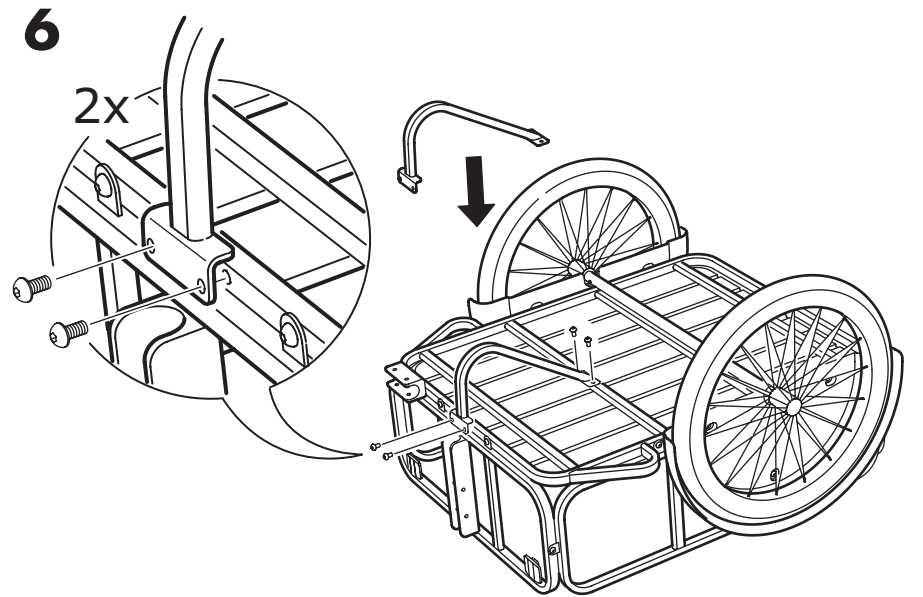
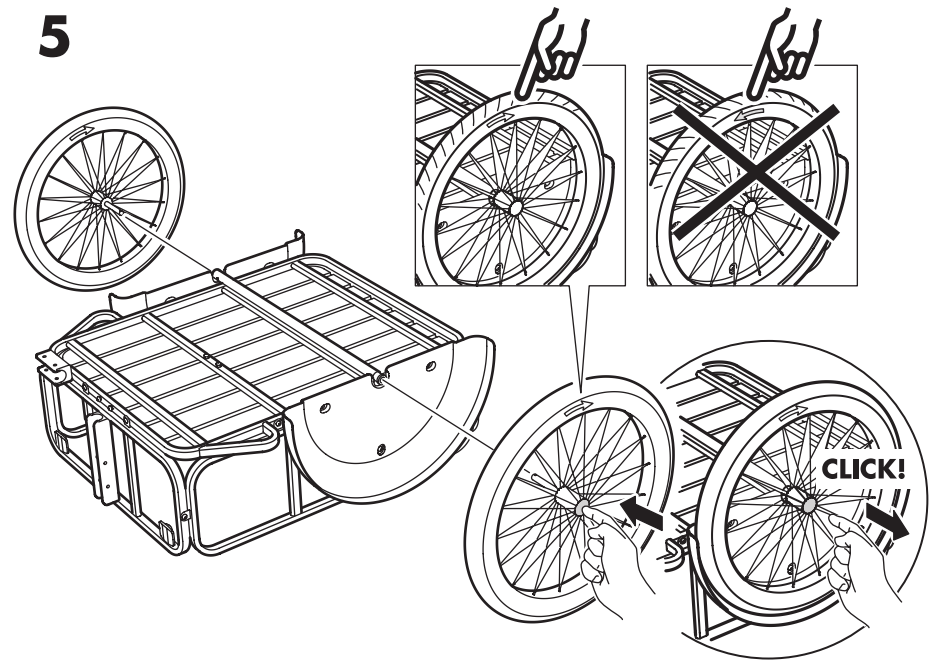
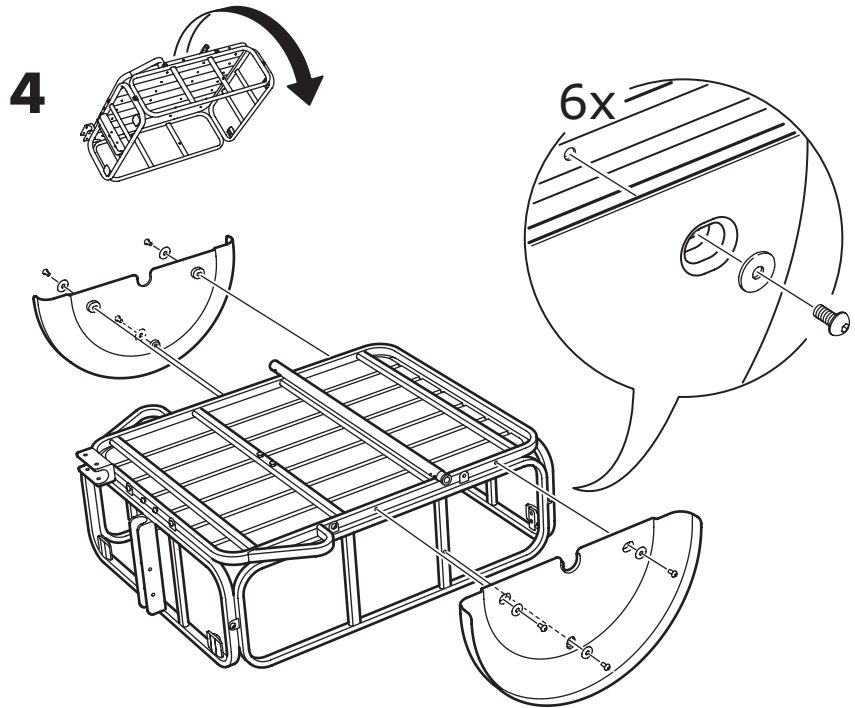
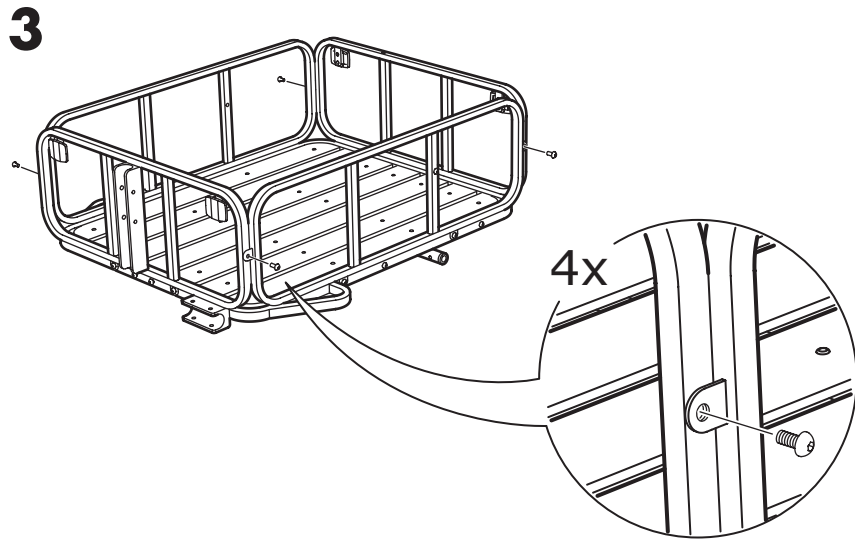

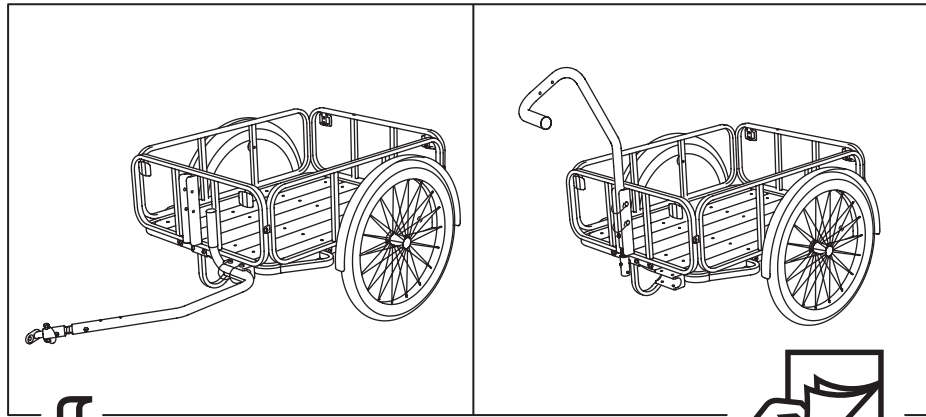

7

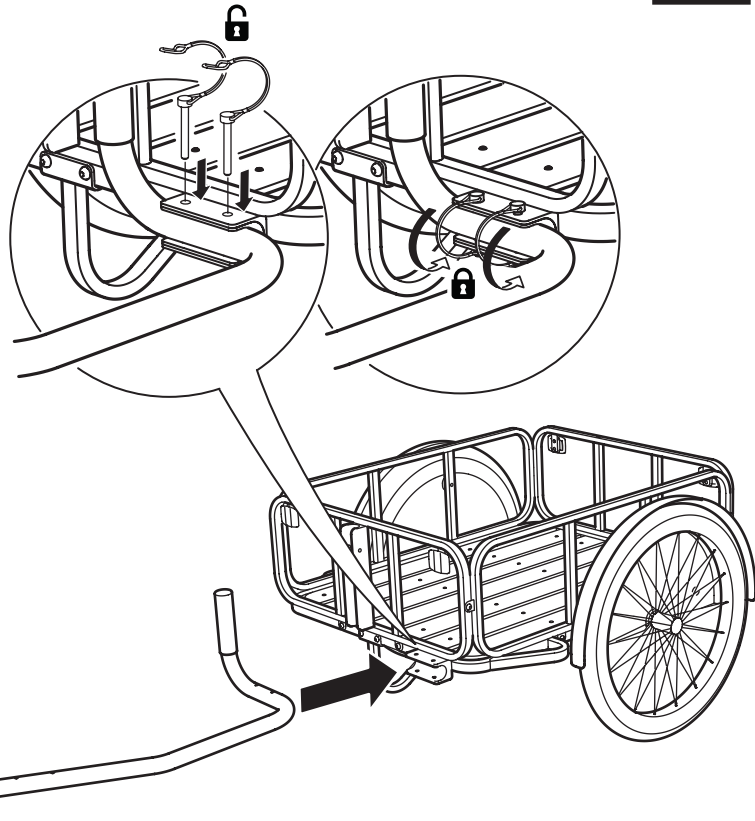

8

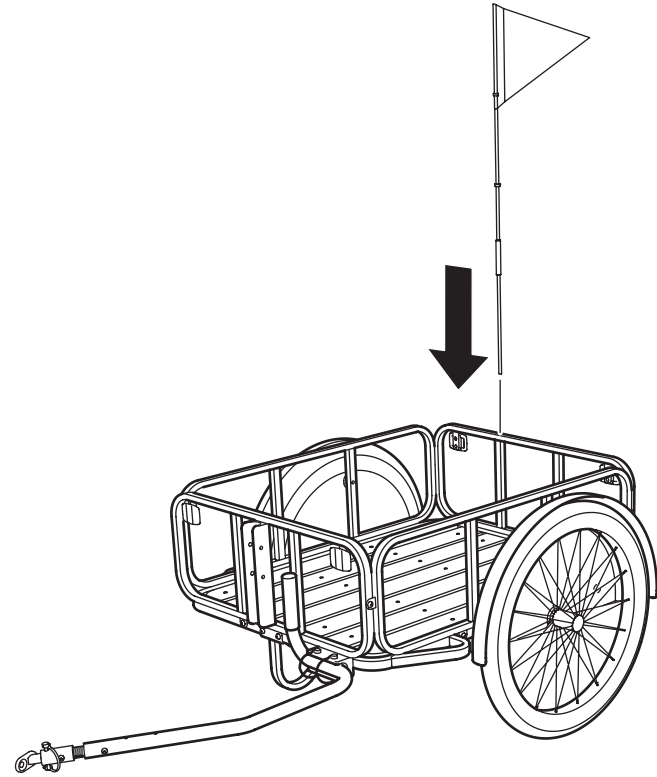

9

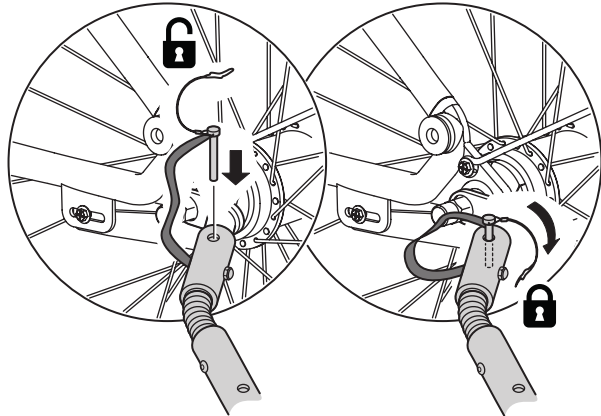
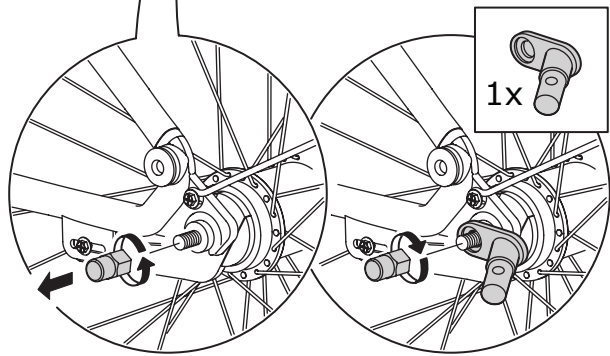
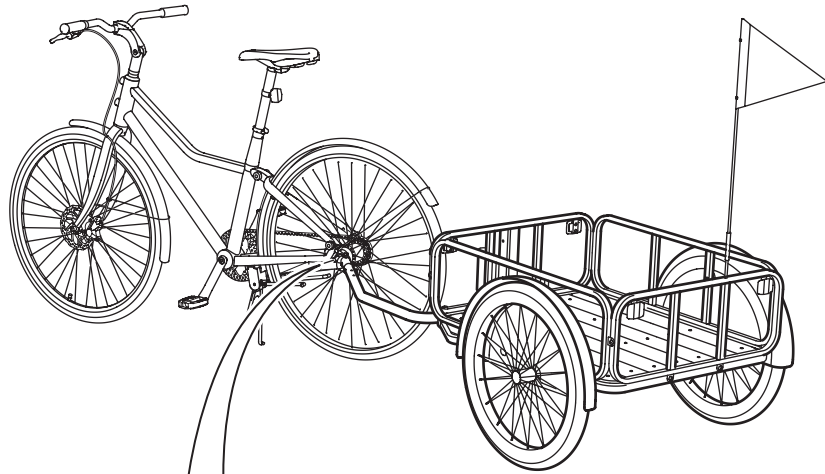

10

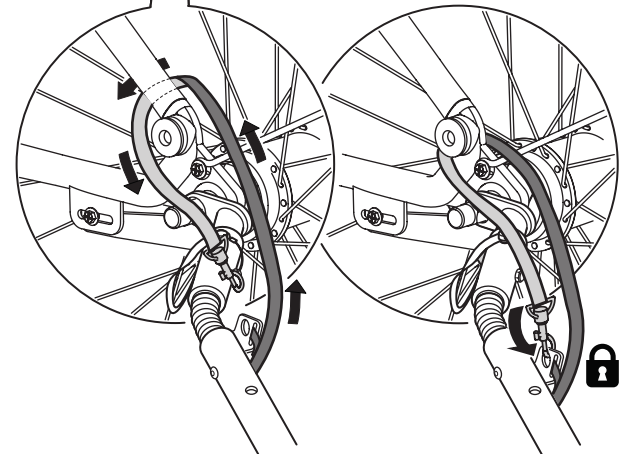
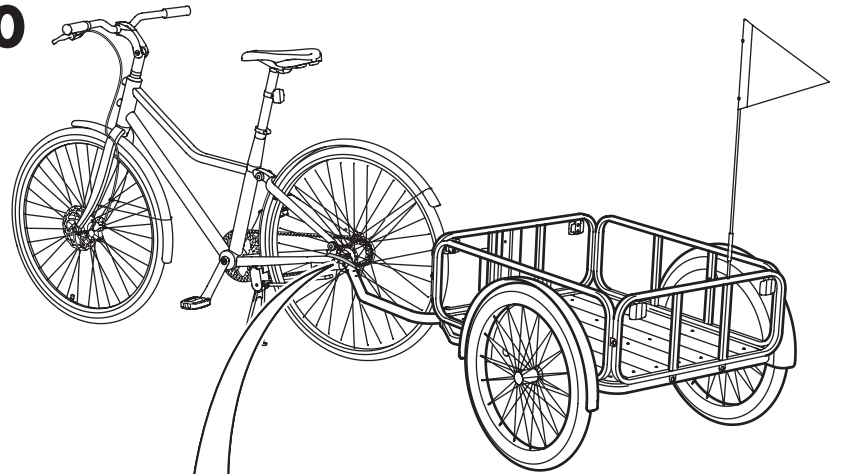

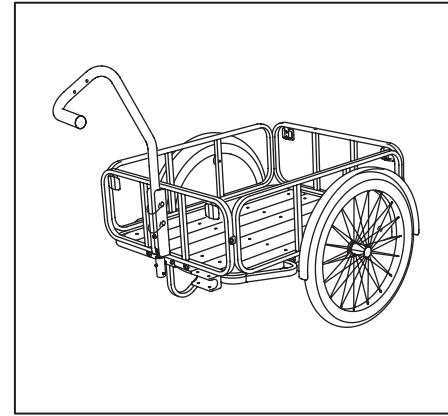
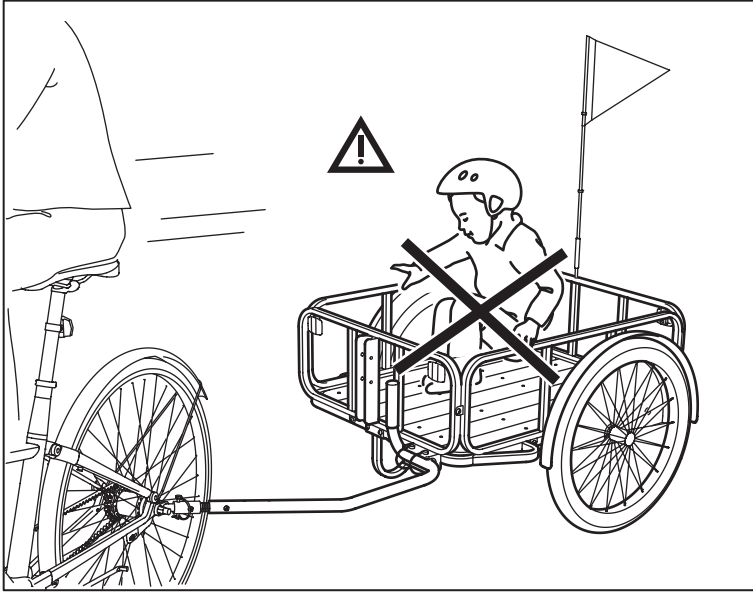

7

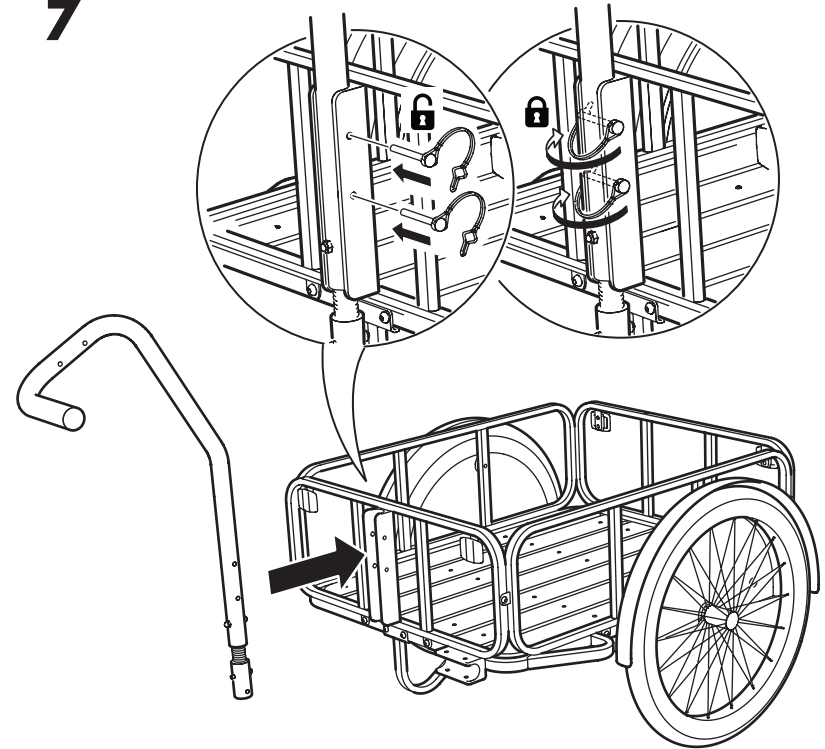

8

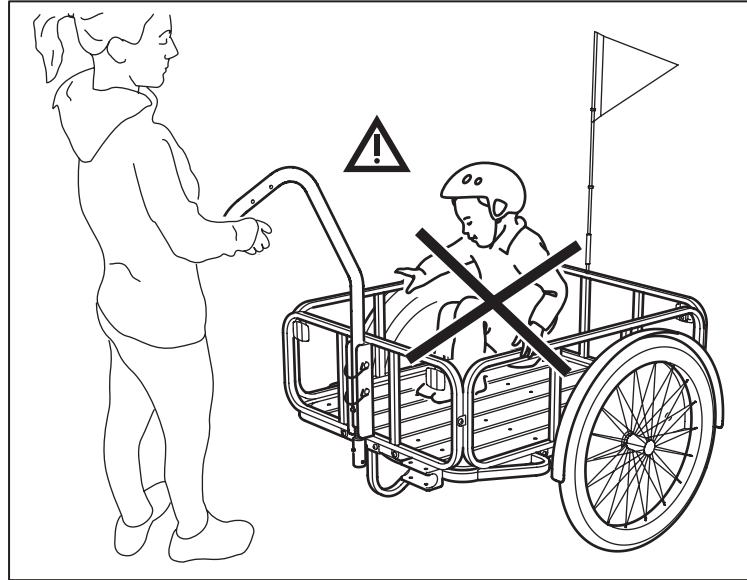
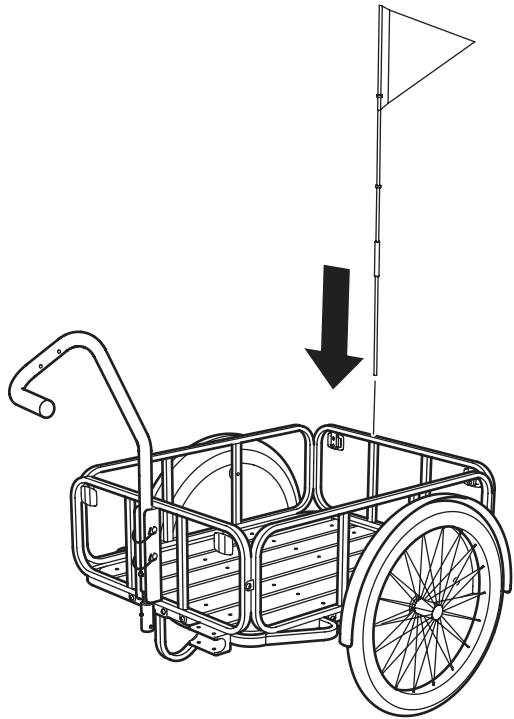

## 6. VÉRIFIER LA REMORQUE AVANT UTILISATION

Avant d'utiliser votre remorque, faites un test sur un terrain plat, à l'écart de la circulation. Il est important de s'assurer que toutes les pièces sont bien fixées et en état de marche.

### VERIFIEZ LES PNEUS

Assurez-vous que les pneus sont gonflés conformément à la pression recommandée. Utilisez pour cela une pompe à vélo équipée d'un manomètre. La pression ne doit pas dépasser la limite recommandée indiquée sur le pneu. Il est préférable d'utiliser une pompe à main ou à pied plutôt qu'un compresseur de station-service, en raison du risque de surgonflage qui pourrait faire exploser le pneu.

### VERIFIEZ LES ELEMENTS REFLECHISSANTS

Vérifiez que les éléments réfléchissants sont correctement positionnés.



**ATTENTION :** Comme c'est le cas pour toutes les pièces mécaniques, les pièces de votre remorque sont soumises à l'usure et à de fortes contraintes. Les matériaux et les pièces sont différents et réagissent différemment à l'usure et aux contraintes répétées. Quand la fin de la durée de vie d'une pièce est dépassée, elle peut subitement lâcher ou ne plus fonctionner et être la cause de blessures pour le cycliste. Toute fissure, rayure ou changement de couleur d'éléments très sollicités indique que la pièce a atteint la fin de sa durée de vie et qu'il faut la remplacer.

## INHOUD

1. WAARSCHUWING	31
2. VEILIGHEID	31
3. VERZORGING EN ONDERHOUD	31
4. ONDERDELEN & COMPONENTEN	32
5. DE FIETSAANHANGER MONTEREN	33
6. DE FIETSAANHANGER TESTEN VOOR GEBRUIK	39

## 1. WAARSCHUWING



- **Waarschuwing!** Je remweg wordt langer als je met een aanhanger fietst.
- Voor de SLADDA fiets van 26" en 28".
- **MERK OP!** Als je de aanhanger met een andere fiets wilt gebruiken, kijk dan in de handleiding van de fiets of de bevestiging past en wat voor soort aanhanger toegestaan is. Let op: bevestig de aanhanger nooit aan een mountainbike, racefiets, e-bike of andere fiets met hulpmotor.
- De SLADDA aanhanger is niet geschikt voor het vervoeren van kinderen of dieren. Volg de handleiding om de aanhanger op de juiste en veilige manier te monteren en te gebruiken.

## 2. VEILIGHEID

Voor je eigen veiligheid: volg altijd de verkeersregels die in jouw land gelden.

## 3. ONDERHOUD

Controleer regelmatig de onderdelen van de aanhanger, zoals montageschroeven, bevestigingen, frame, reflectoren en banden.

**IKEA of Sweden AB**  
34381 Älmhult  
Sweden

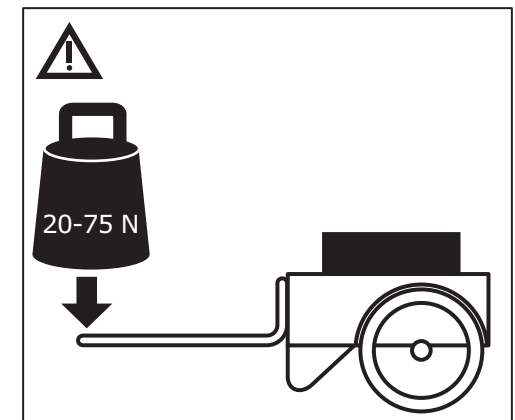
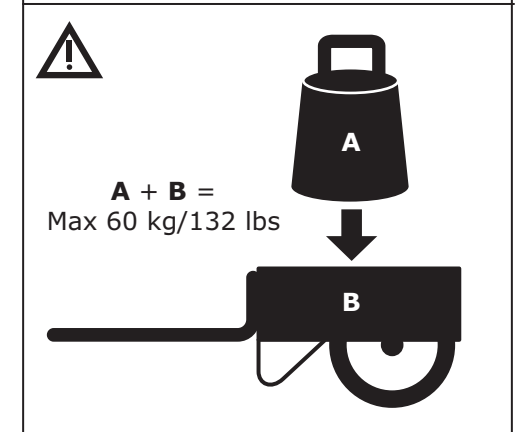
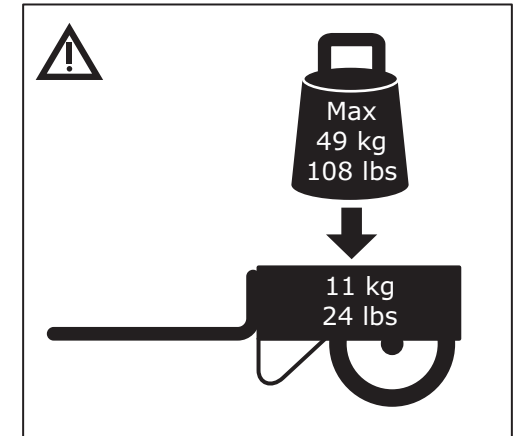

#### 4. ONDERDELEN & COMPONENTEN

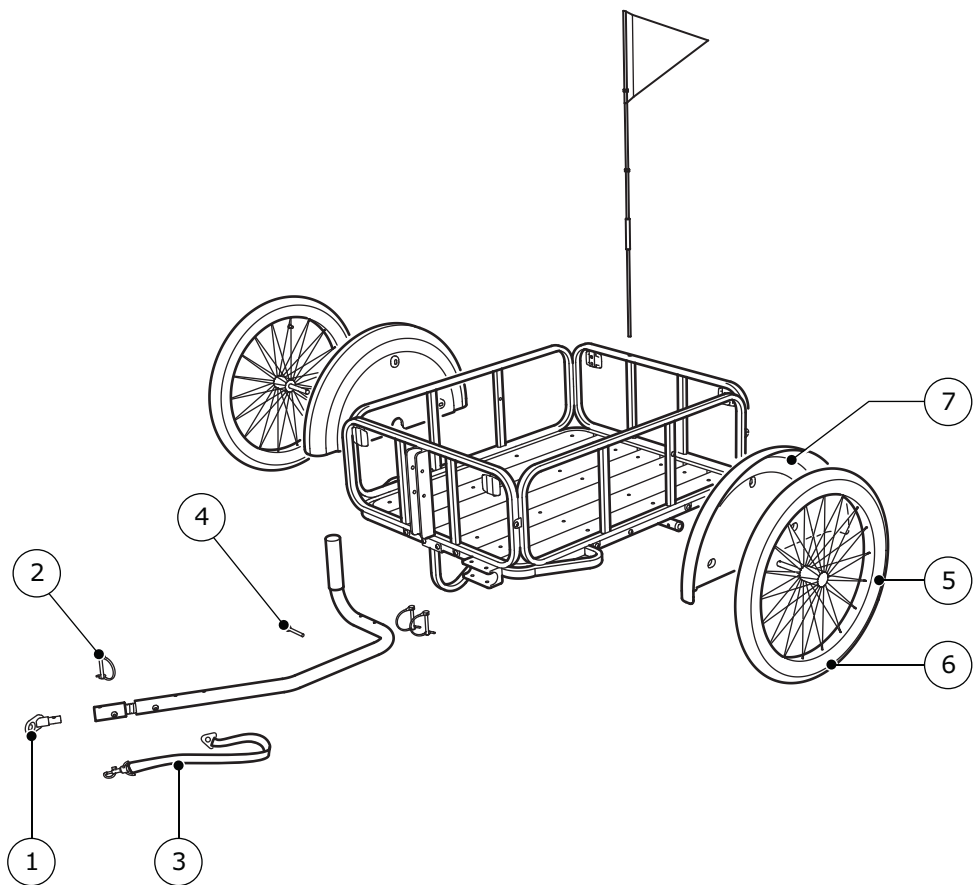

- 1 Koppeling (152921)
- 2 D-vormig slot (152922)
- 3 Veiligheidsriem (152923)
- 4 Schroef (152924)
- 5 Wiel, Band & binnenband (152925)
- 6 Band (152926)
- 7 Spatscherf (152927)



## 5. DE FIETSAANHANGER MONTEREN

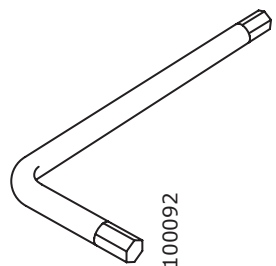
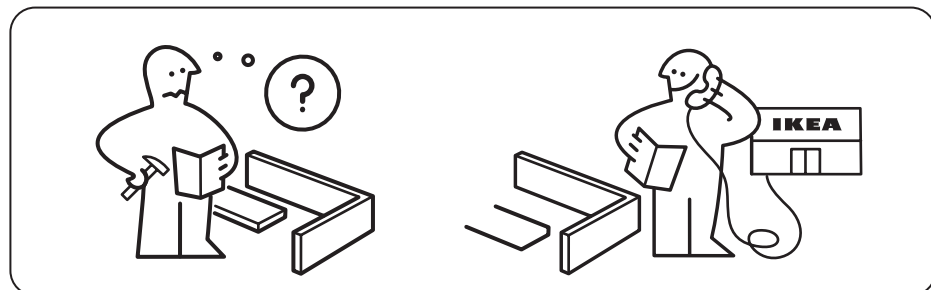
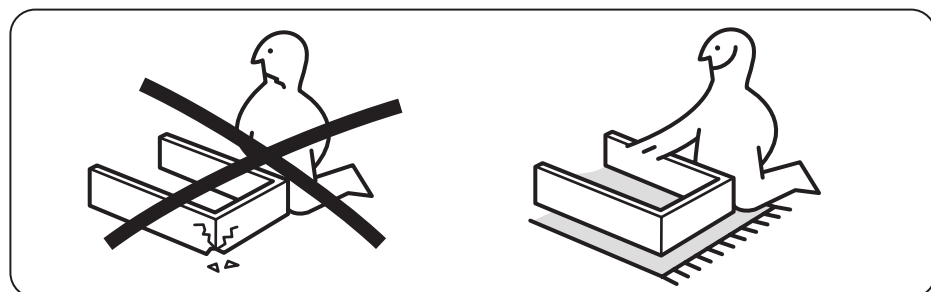
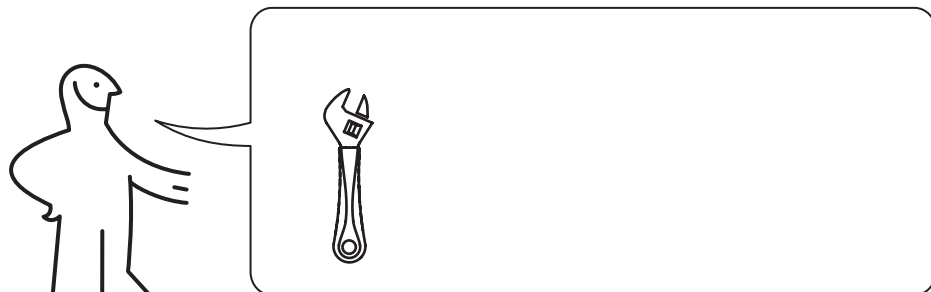

1x

1

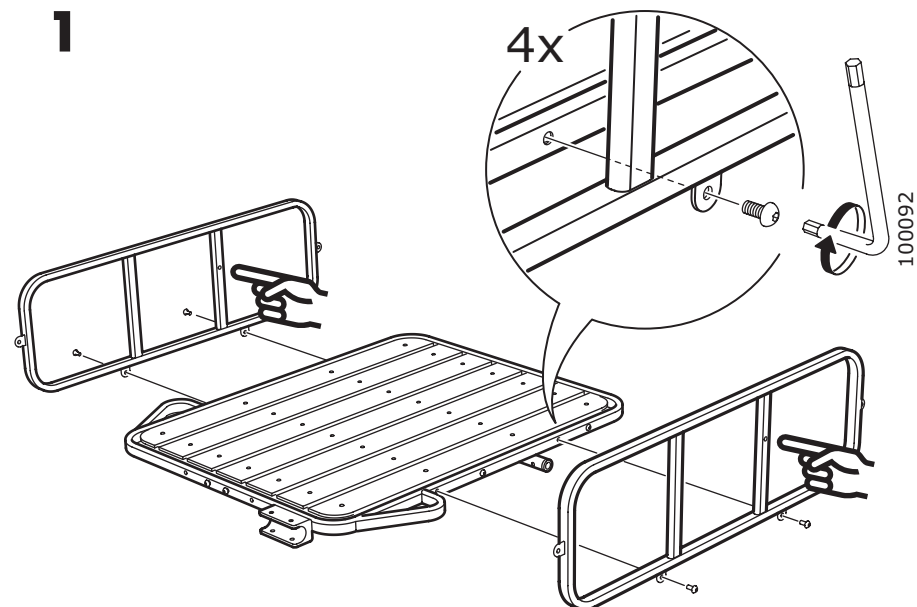

2

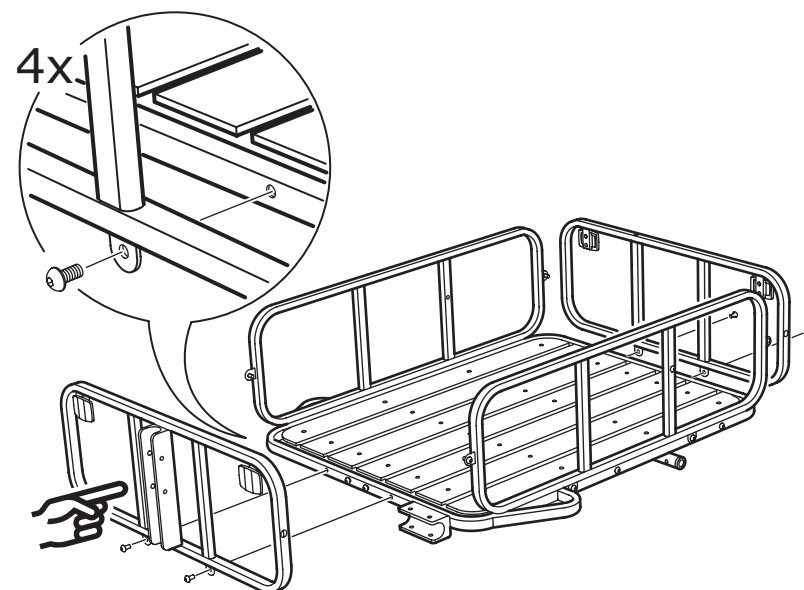

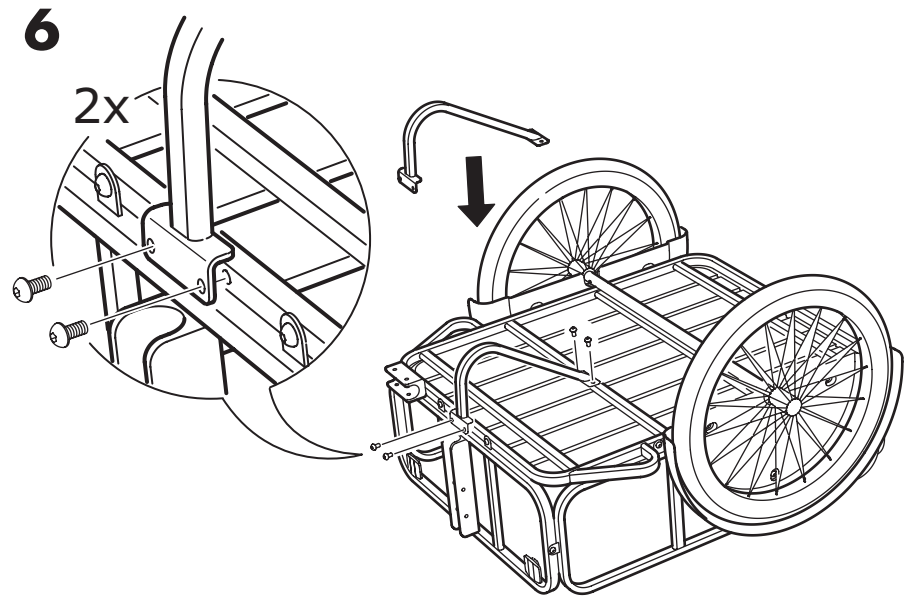
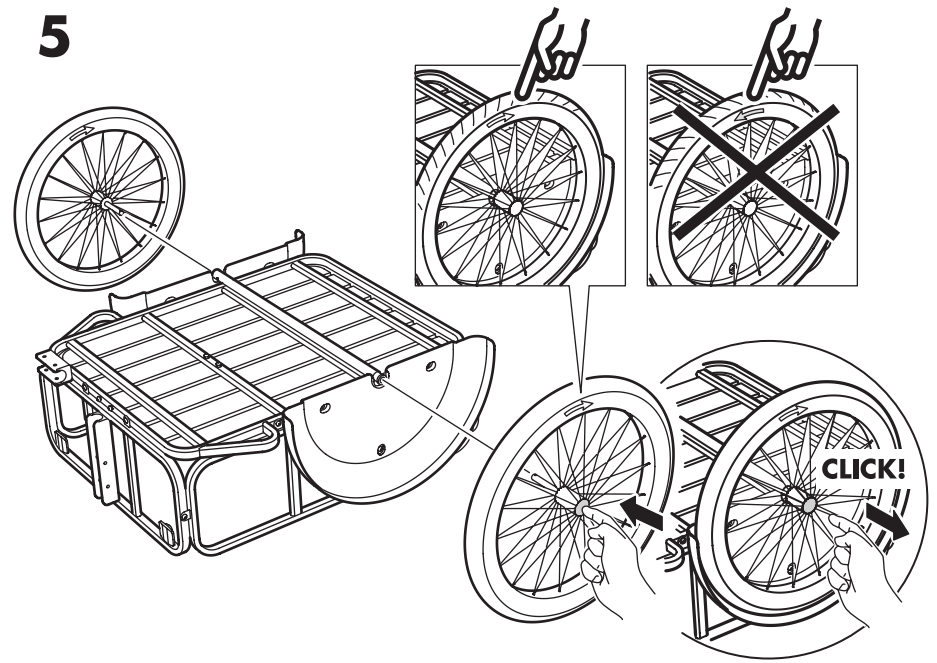
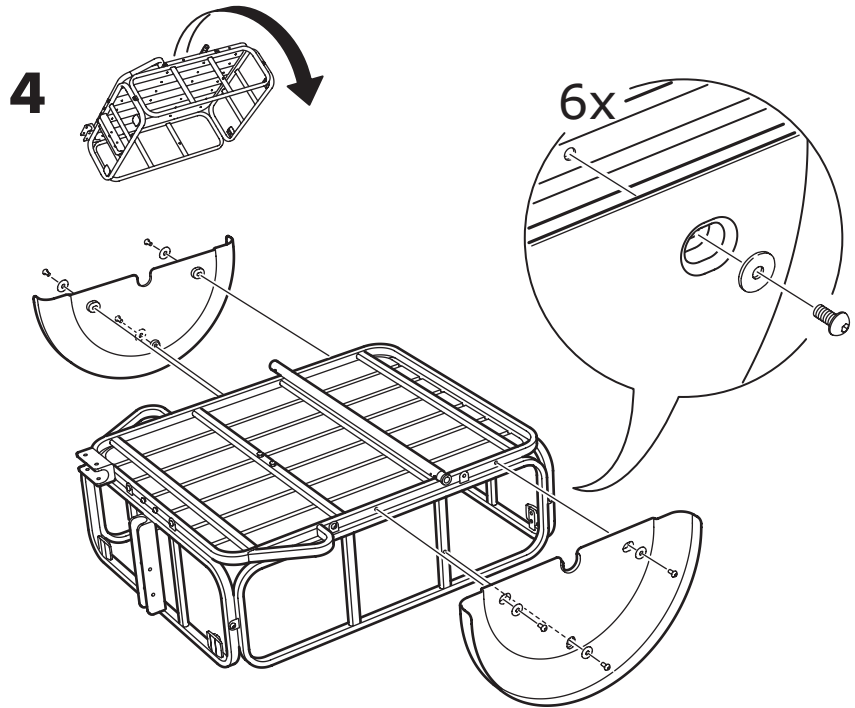
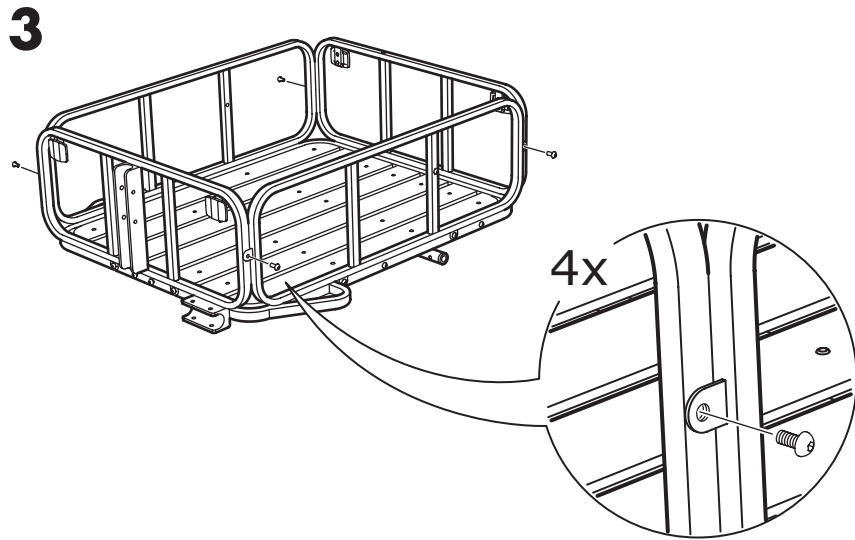

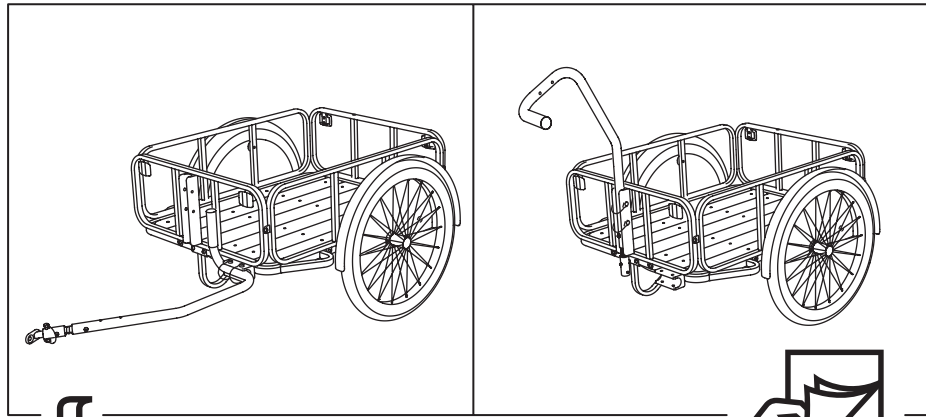

7

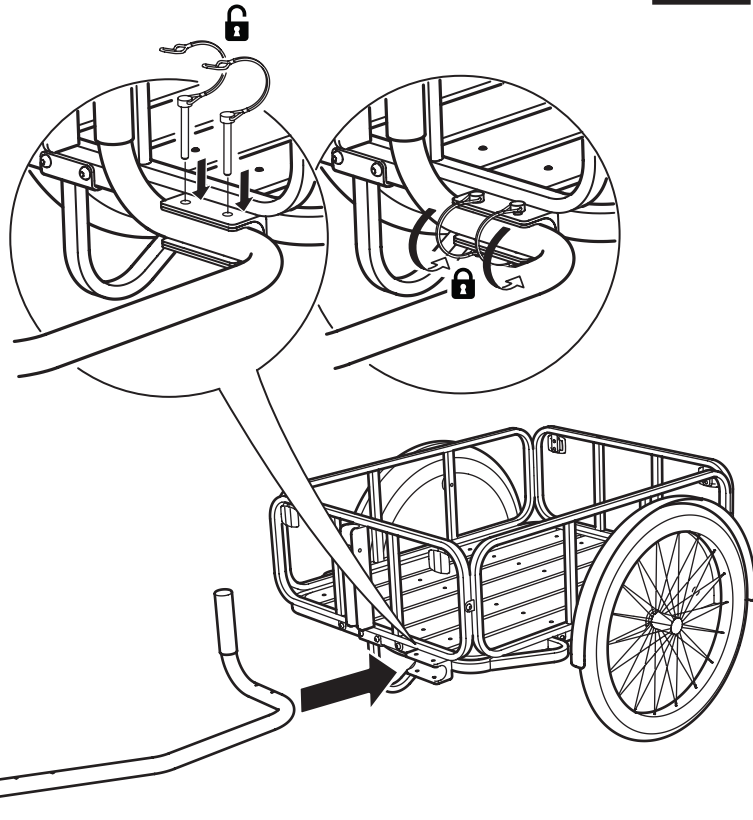

8

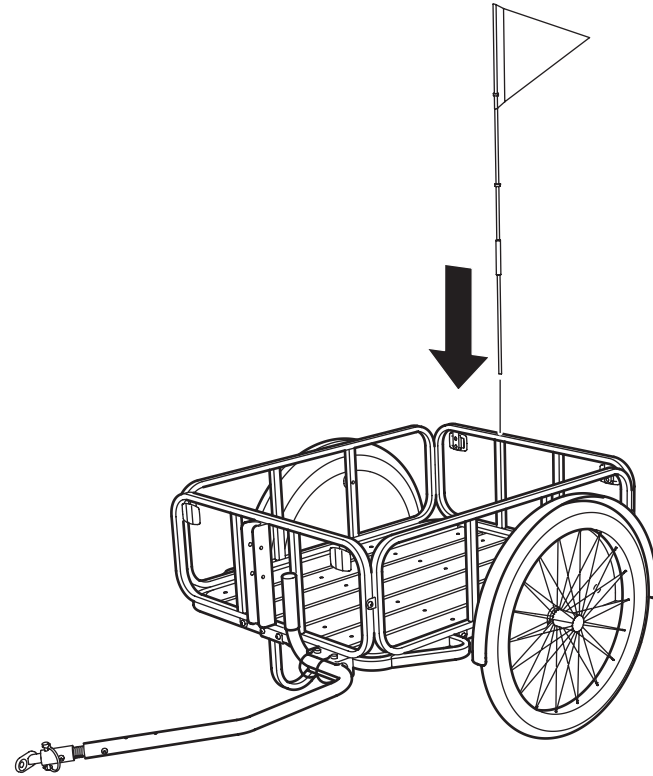

9

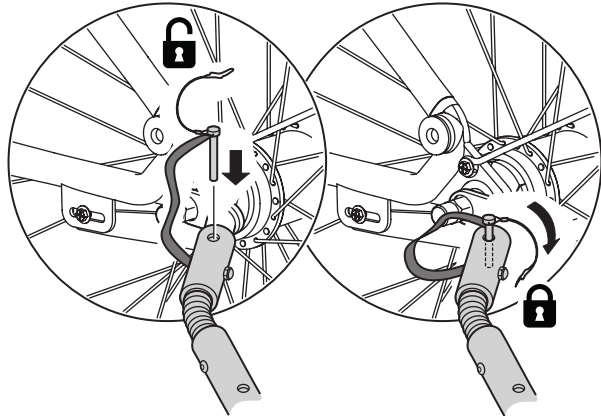
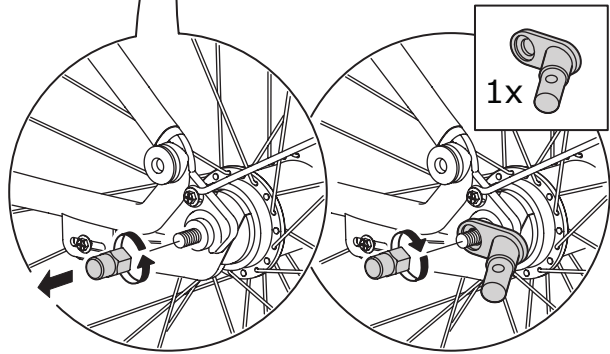
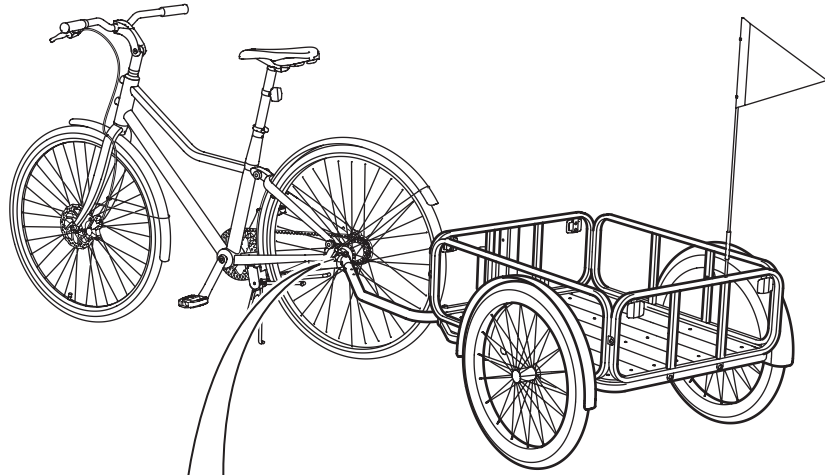

10

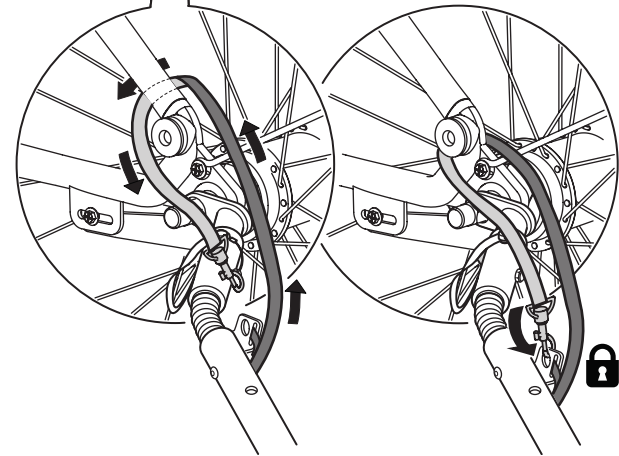
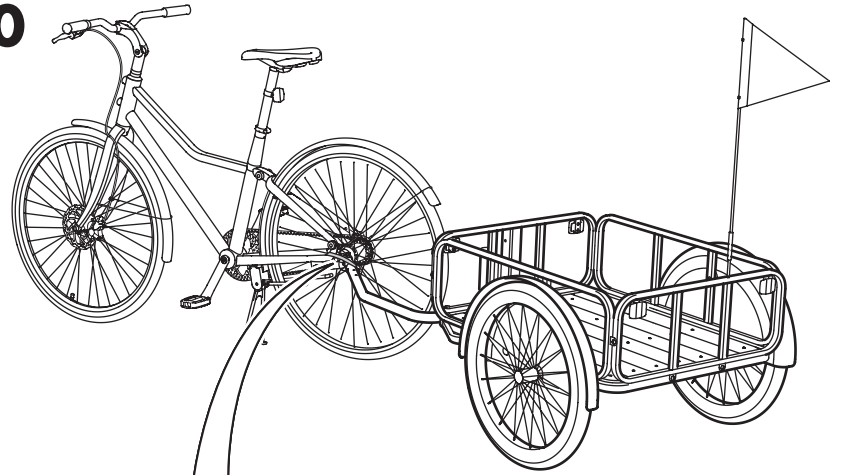

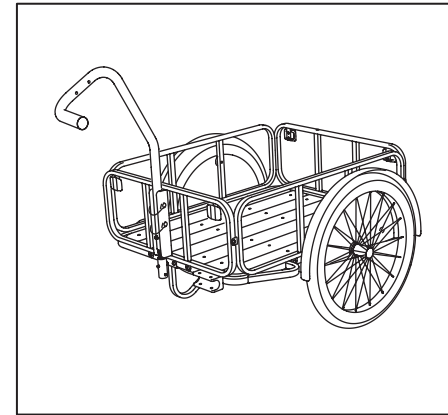
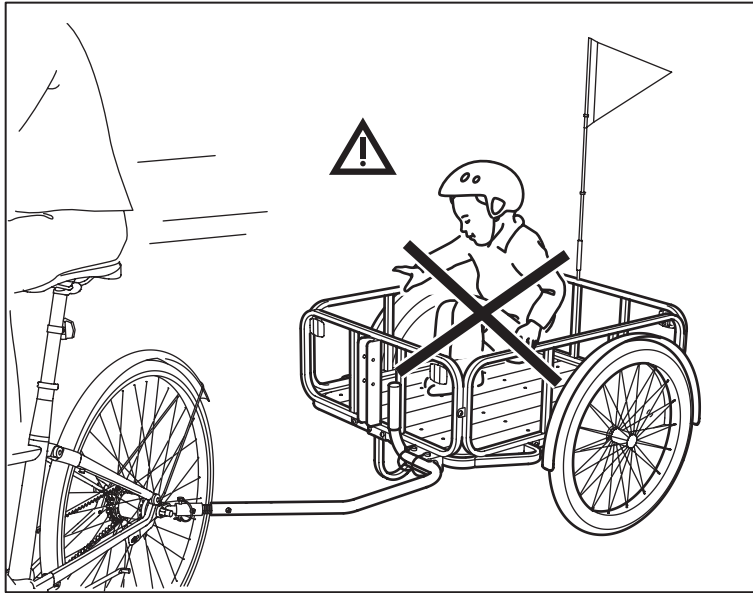

7

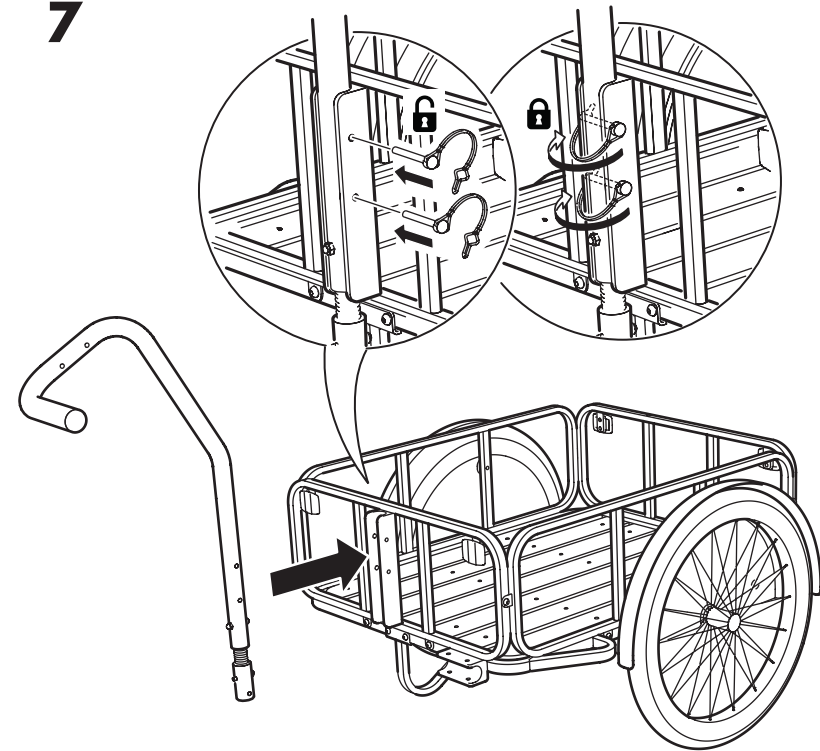

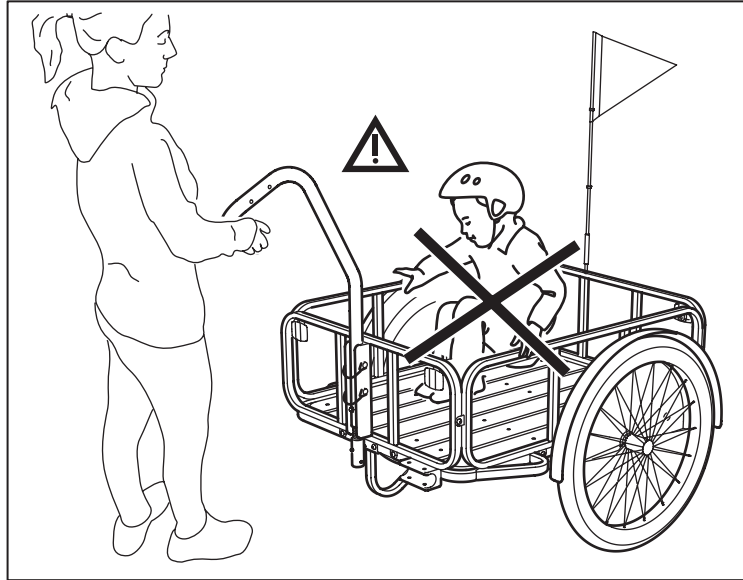
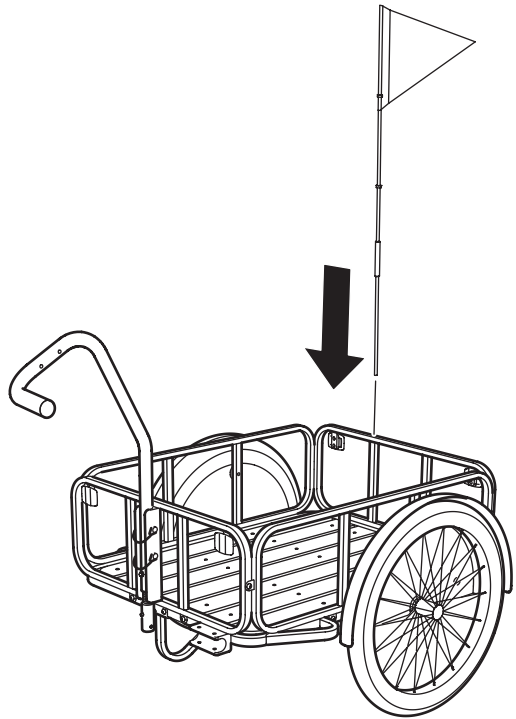

## 6. DE FIETSAANHANGER TESTEN VOOR GEBRUIK

Voordat je met de aanhanger gaat rijden, dien je altijd eerst een veiligheidscheck te doen op een vlakke ondergrond en op een plek waar niet veel verkeer is. Het is belangrijk dat je goed controleert of alle onderdelen goed vastzitten en juist functioneren.

### CONTROLEER DE BANDEN

Zorg dat de banden de juiste bandenspanning hebben. Dat kan je het beste doen door een fietspomp met een drukmeter te gebruiken. Pomp de banden niet harder op dan de maximale bandenspanning zoals vermeld op de band. Je kan beter een hand- of een voetspomp gebruiken dan een luchtpomp. Als je de band te hard oppompt, kan hij namelijk klappen.

### CONTROLEER DE REFLECTOREN

Controleer of alle reflectoren op de juiste plaats zitten.



**WAARSCHUWING:** Zoals alle andere mechanische componenten zal de aanhanger worden blootgesteld aan slijtage en andere beproevingen. Materialen en onderdelen kunnen verschillend reageren op slijtage. Als de levensduur van een component ten einde is, kan dit plotseling stoppen met functioneren en kan de fietser letsel oplopen. Barsten, krassen of kleurveranderingen op gebieden die aan veel belasting onderhevig zijn, kunnen erop duiden dat de levensduur van dat onderdeel ten einde is en dat dit vervangen moet worden.

ÍNDICE

1. ADVERTENCIA	40
2. SEGURIDAD	40
3. MANTENIMIENTO	40
4. PARTES Y COMPONENTES	41
5. CÓMO MONTAR EL REMOLQUE	42
6. PRUEBA EL REMOLQUE ANTES DE USARLO	48

1. ATENCIÓN



- **iAtención!** Aumenta la distancia de frenado cuando circules en bicicleta con un remolque.
- Encaja en la bicicleta SLADDA de 26" y 28".
- **iATENCIÓN!** Si quieres utilizar este remolque con una bicicleta diferente, consulta en el manual de dicha bicicleta las fijaciones y remolque adecuados. ¡Atención! No conectes nunca el remolque a una bicicleta de montaña, de carreras, bicicleta eléctrica o cualquier otra con asistencia de motor.
- El remolque SLADDA no es adecuado para el transporte de niños o animales. Sigue el manual para montar y utilizar el remolque de forma segura y correcta.

2. SEGURIDAD

Cumple las normas de tráfico de tu país, por tu seguridad.

3. MANTENIMIENTO

Comprueba con regularidad el estado de los componentes del remolque como tornillos de montaje, fijaciones, estructura, tiras reflectantes y neumáticos.

**IKEA of Sweden AB**  
34381 Älmhult  
Sweden

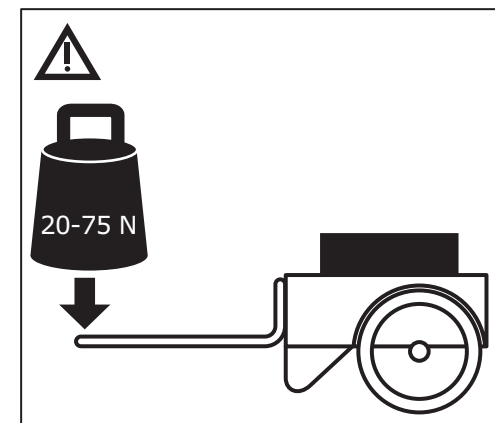
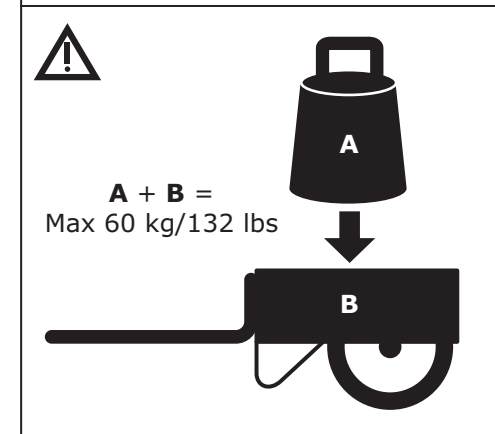
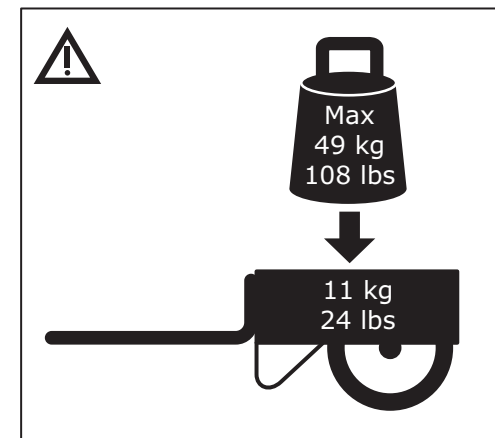



#### 4. PARTES Y COMPONENTES

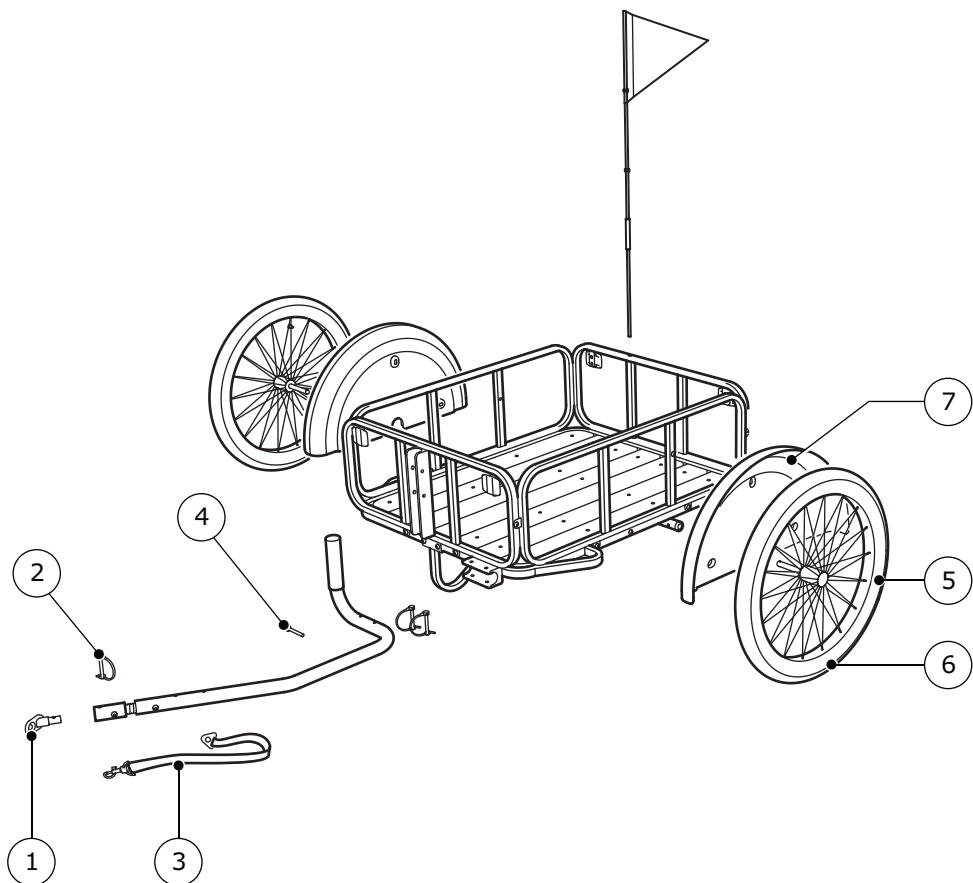

- 1 Conector (152921)
- 2 Mosquetón (152922)
- 3 Correa de seguridad (152923)
- 4 Tornillo M5 (152924)
- 5 Rueda, cámara de aire (152925)
- 6 Rueda (152926)
- 7 Guardabarros (152927)

## 5. CÓMO MONTAR EL REMOLQUE

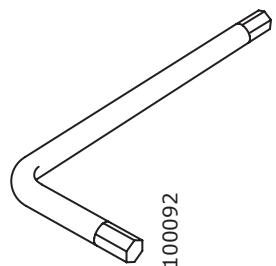
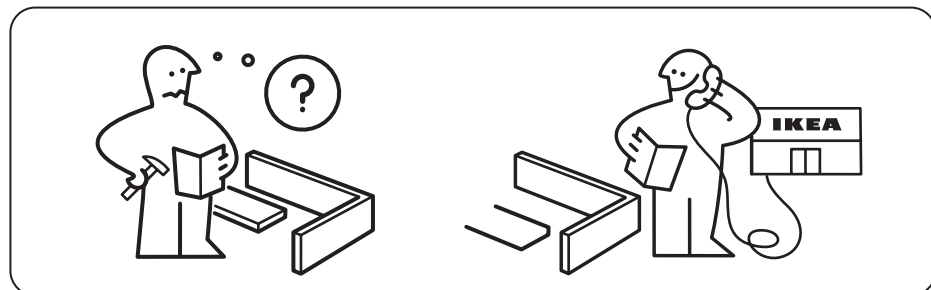
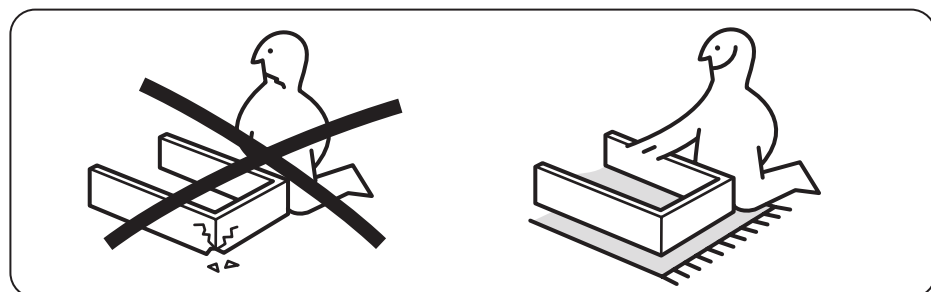
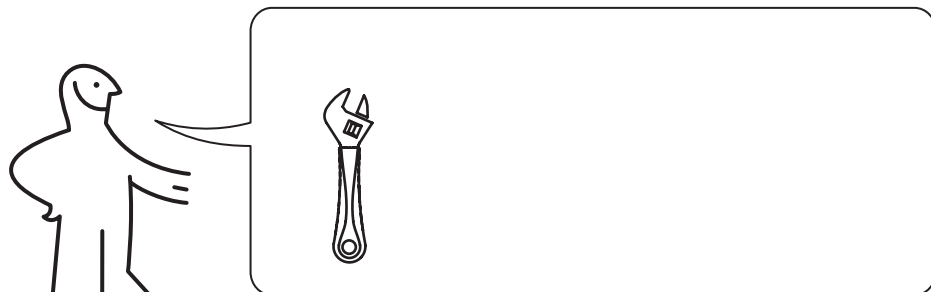

100092

1x

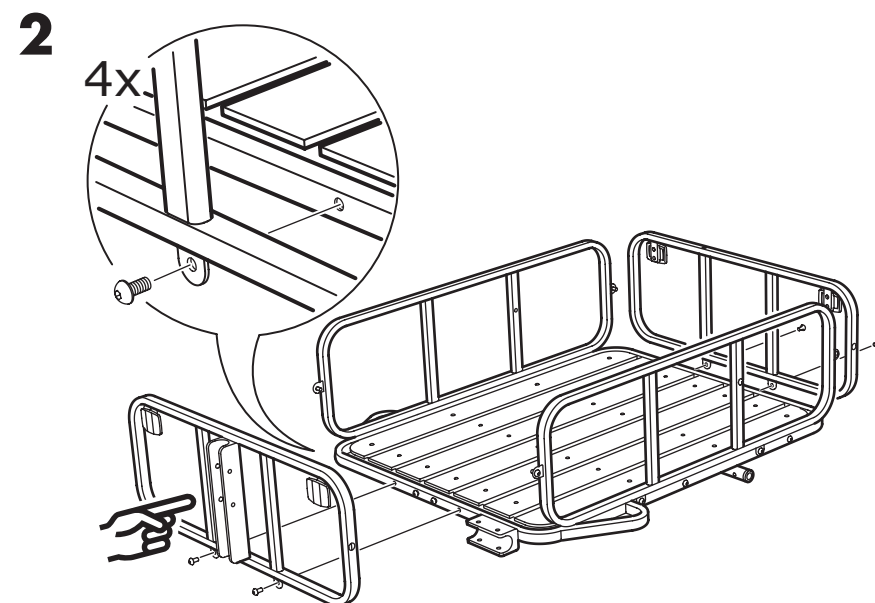
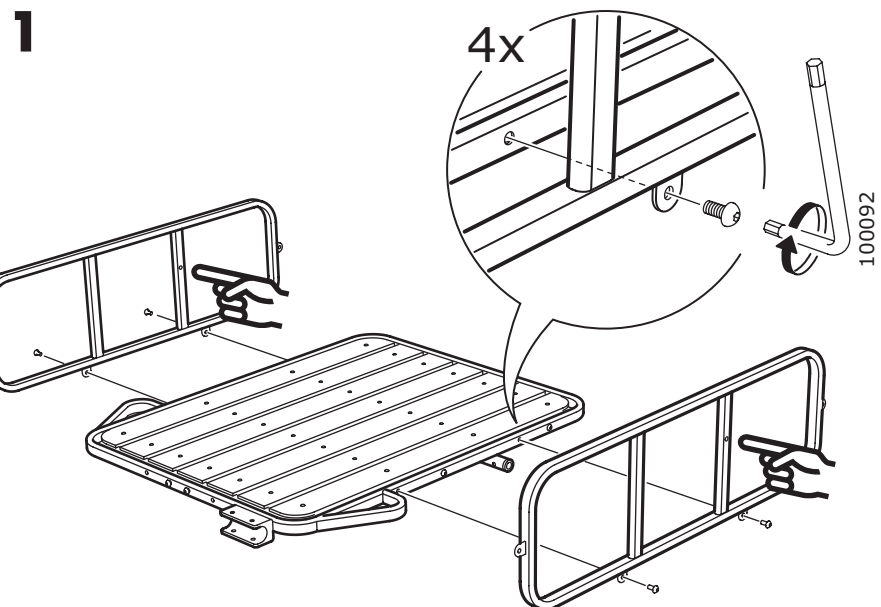

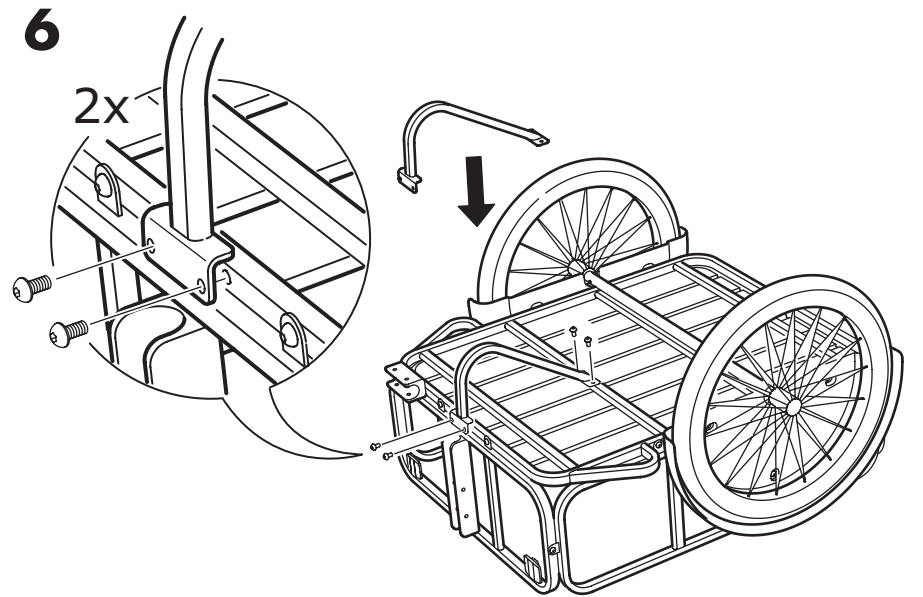
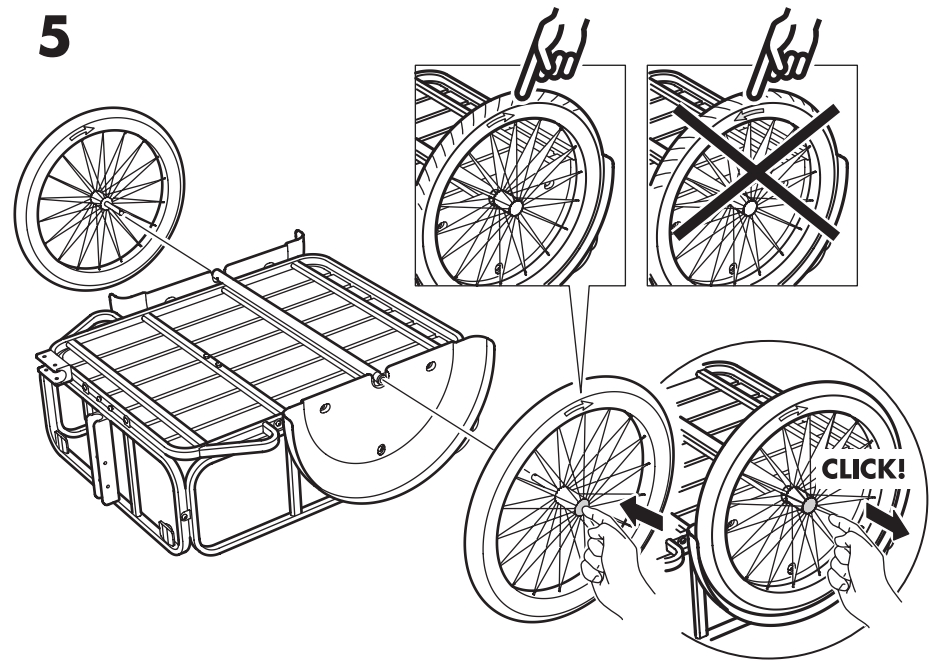
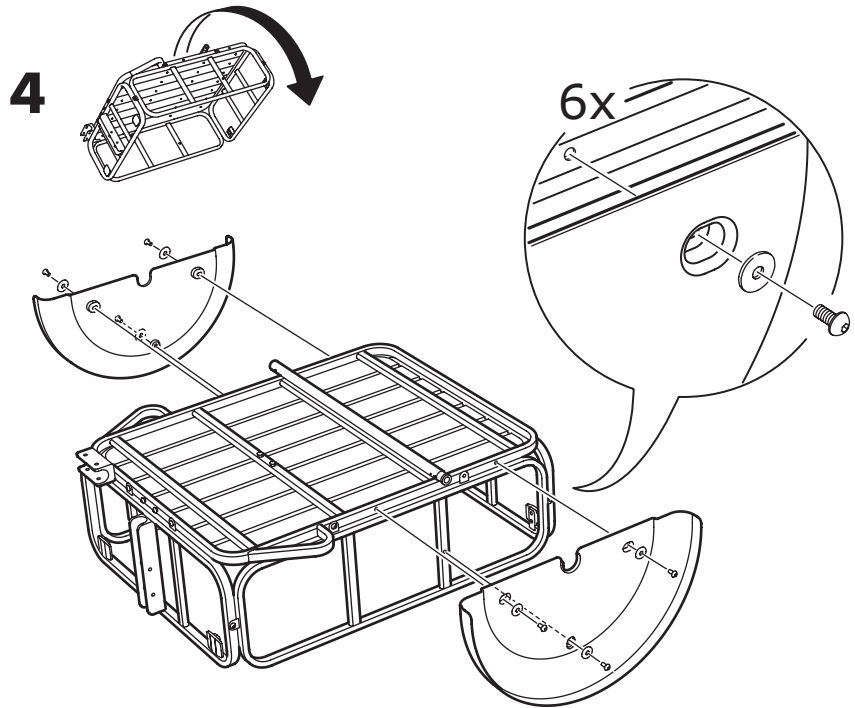
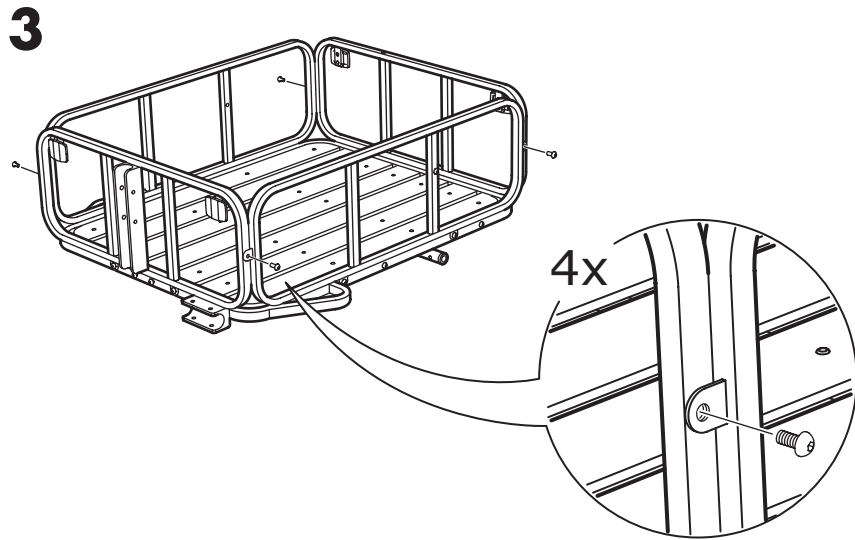

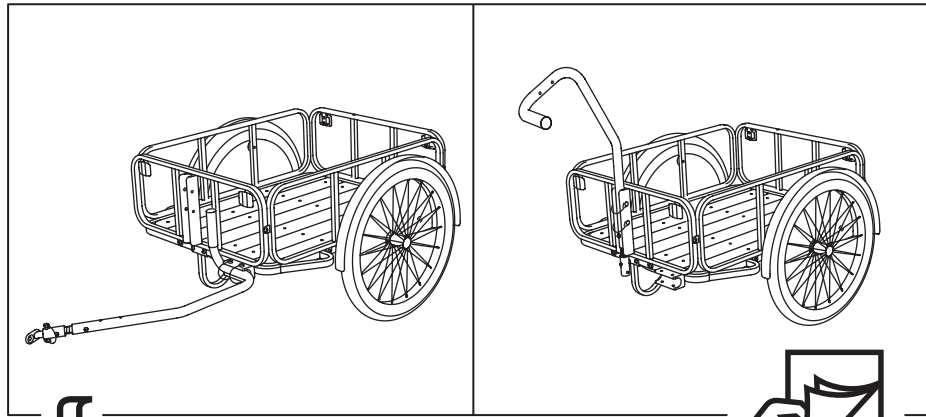

7

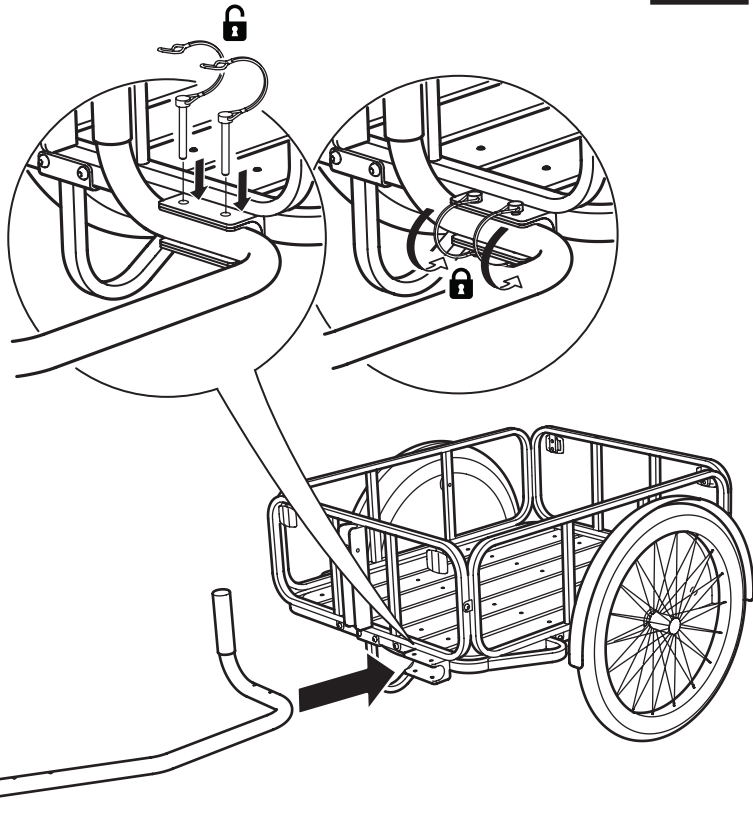

8

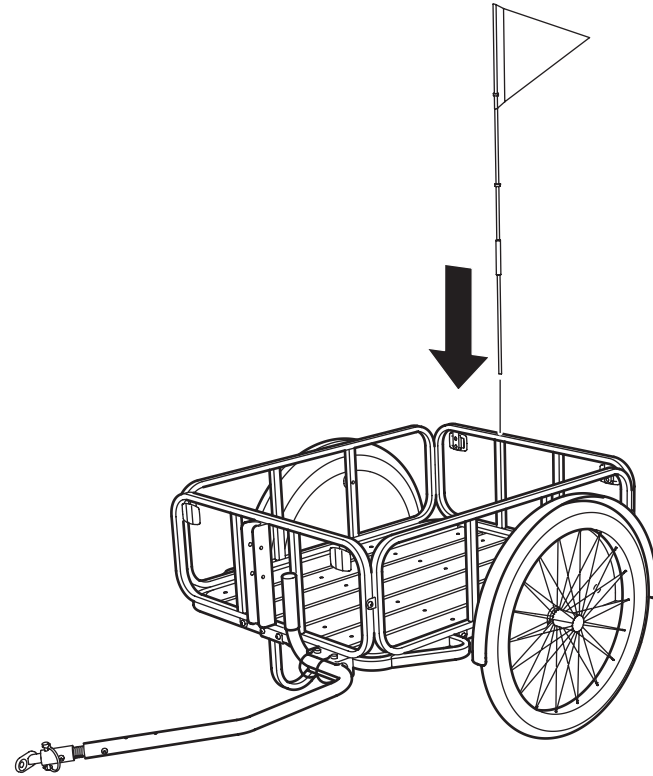

9

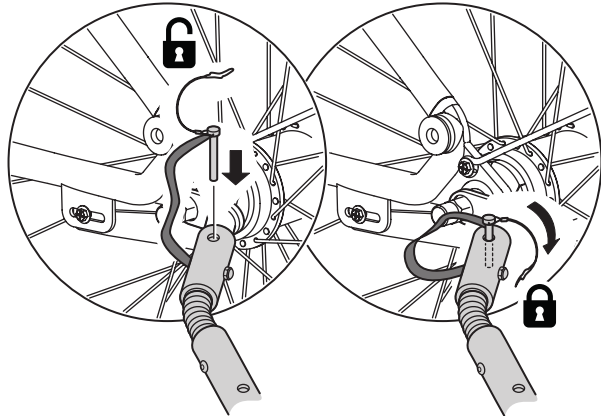
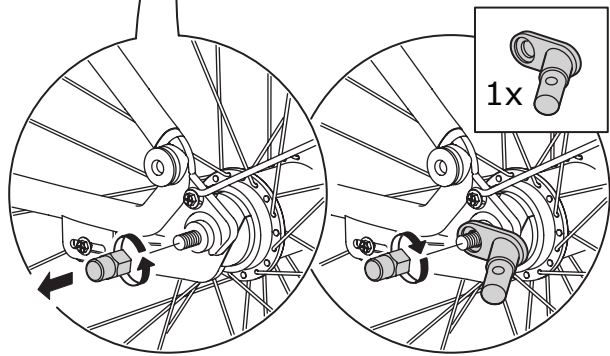
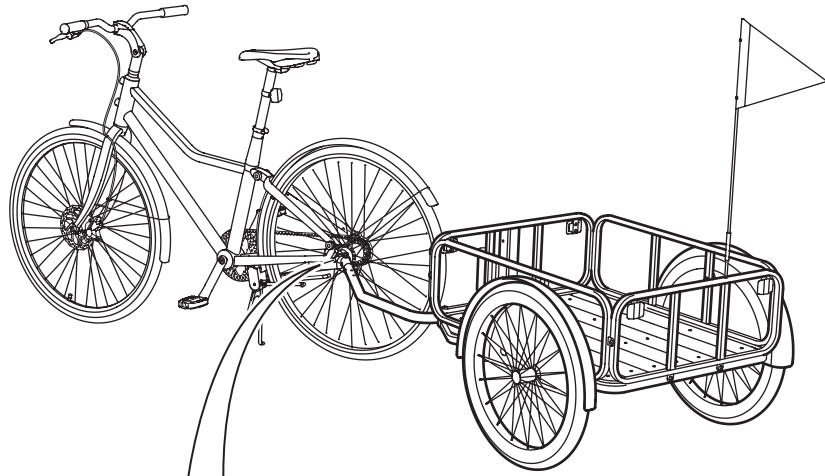

10

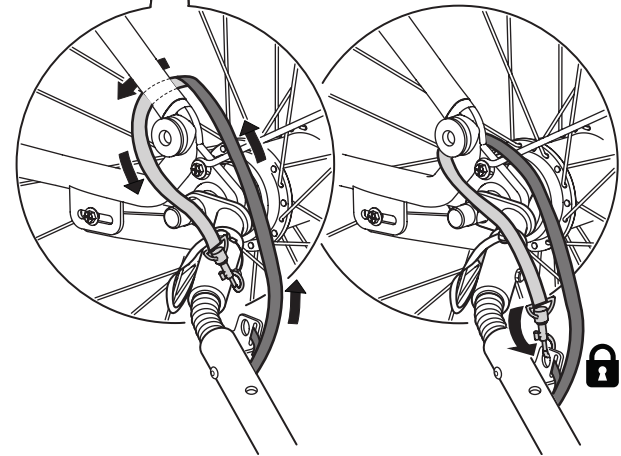
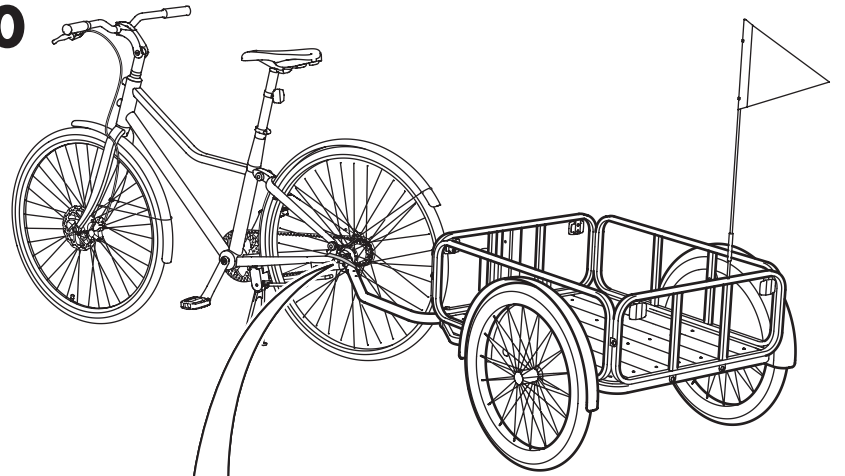

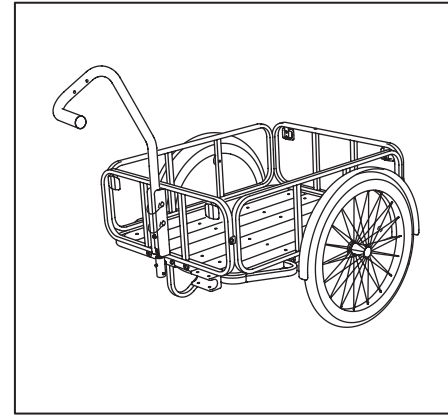
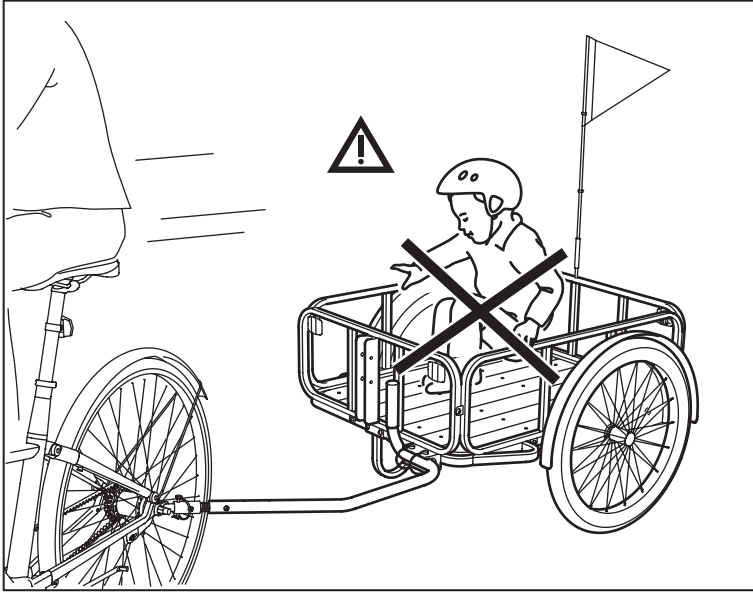

7

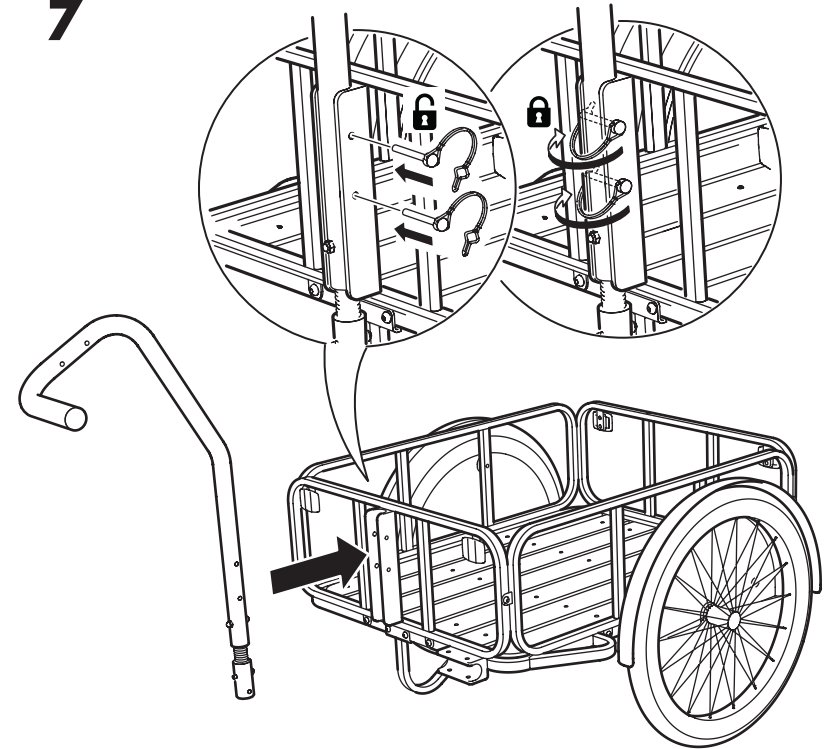

8

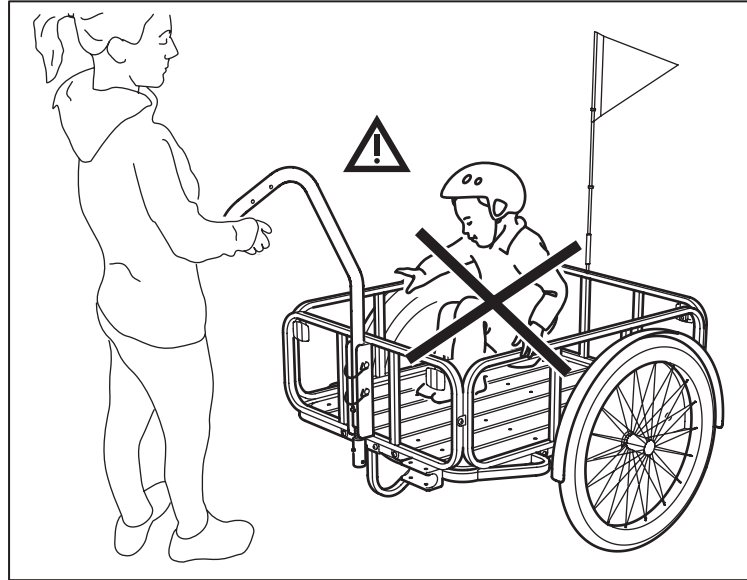
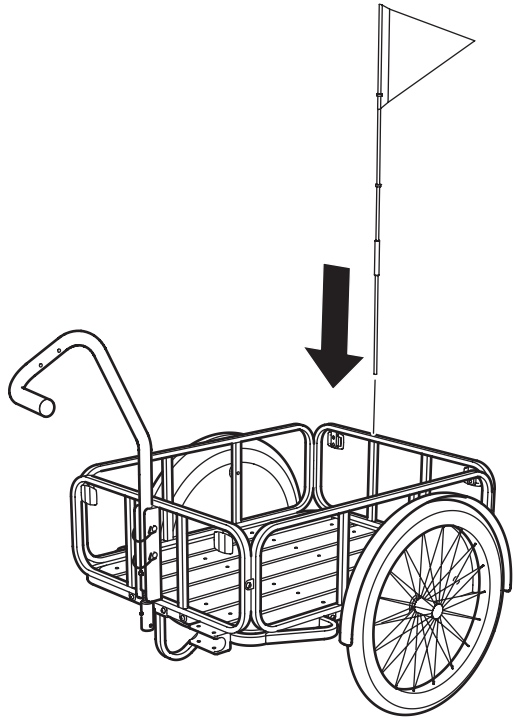

## 6. PRUEBA EL REMOLQUE ANTES DE USARLO

Antes de utilizar el remolque haz un control de seguridad en una zona llana y alejada del tráfico. Es importante comprobar que todos los componentes estén bien fijados y funcionen correctamente.

### COMPRUEBA LAS RUEDAS

Comprueba que las ruedas tengan la presión recomendada con una bomba de inflado con manómetro. La presión no debe exceder el límite recomendado que indican las ruedas. Es preferible utilizar una bomba accionada con el pie o la mano, que una bomba de gasolinera, porque el exceso de inflado podría causar la explosión de la rueda.

### COMPRUEBA LOS REFLECTORES

Comprueba que los reflectores estén correctamente situados.



**¡ATENCIÓN!** Como todos los componentes mecánicos, el remolque está sometido al desgaste. Los distintos materiales de los componentes pueden reaccionar de diferentes maneras al desgaste. Los componentes que hayan superado el período de duración previsto podrían romperse, provocando lesiones al usuario de la bicicleta. Cualquier tipo de grietas, rayones o cambios de color en zonas sujetas a un fuerte desgaste indican que el componente ha alcanzado su duración máxima y debe ser sustituido.



**INDICE**

1. AVVERTENZE	49
2. SICUREZZA	49
3. MANUTENZIONE	49
4. COMPONENTI	50
5. MONTAGGIO DEL RIMORCHIO	51
6. CONTROLLO DEL RIMORCHIO PRIMA DELL'USO	57

**1. AVVERTENZA**



- **Avvertenza!** Quando utilizzi un rimorchio per bicicletta, la distanza di frenata aumenta.
- Utilizzabile con la bicicletta SLADDA da 26" e 28".
- **N.B.** Prima di usare questo rimorchio con un'altra bicicletta, consulta il relativo manuale di istruzioni per verificare quali sono gli accessori di montaggio e i rimorchi compatibili. N.B.: non agganciare mai questo rimorchio a mountain bike, biciclette da corsa, biciclette elettriche o a pedalata assistita.
- Il rimorchio per bicicletta SLADDA non è adatto al trasporto di bambini e animali. Segui il manuale di istruzioni per montare e utilizzare il rimorchio in maniera corretta e sicura.

**2. SICUREZZA**

Per la tua sicurezza, rispetta sempre il codice della strada.

**3. MANUTENZIONE**

Controlla regolarmente i componenti del rimorchio, come viti, accessori di montaggio, telaio, catarifrangenti e gomme.

**IKEA of Sweden AB**  
34381 Älmhult  
Sweden

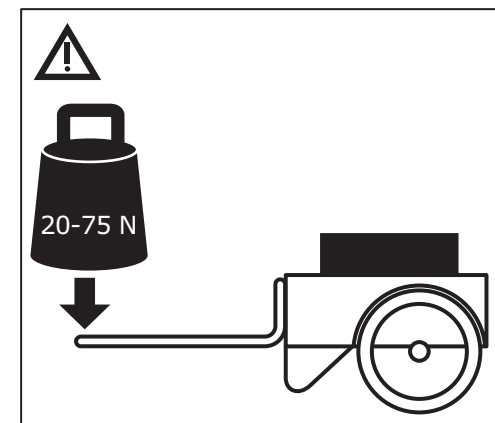
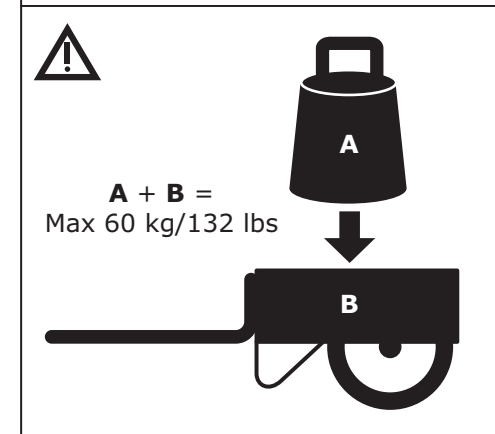
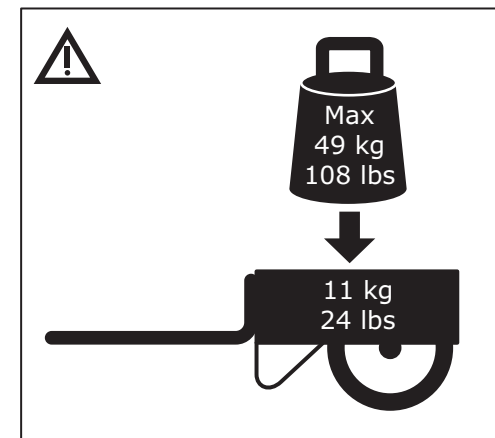

## 4. COMPONENTI

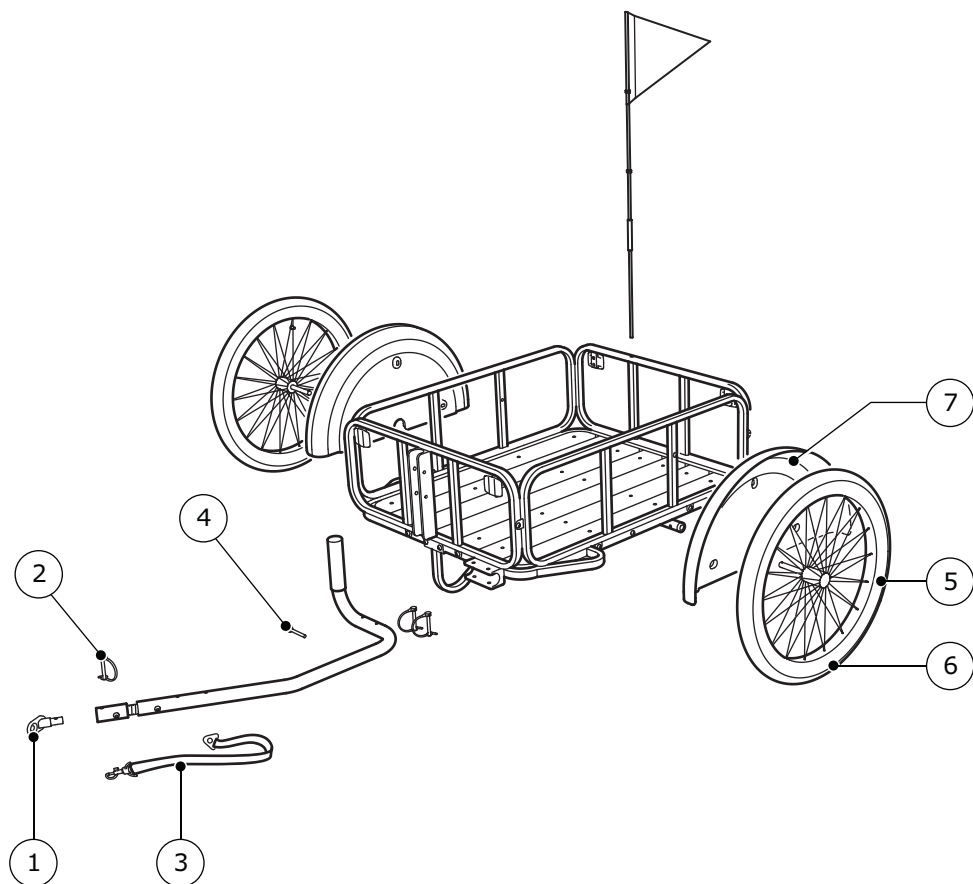

- 1 Raccordo (152921)
- 2 Perno di sicurezza (152922)
- 3 Cinghia di sicurezza (152923)
- 4 Vite M5 (152924)
- 5 Gomma, camera d'aria (152925)
- 6 Gomma (152926)
- 7 Parafango (152927)

## 5. MONTAGGIO DEL RIMORCHIO

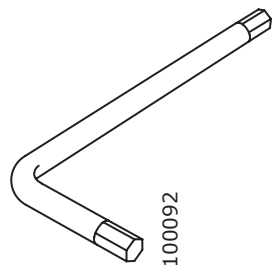
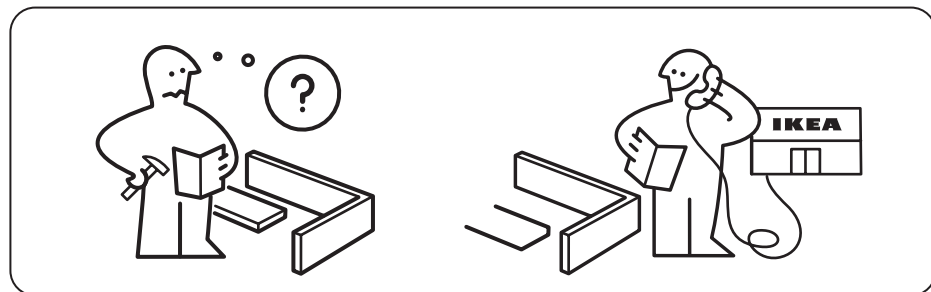
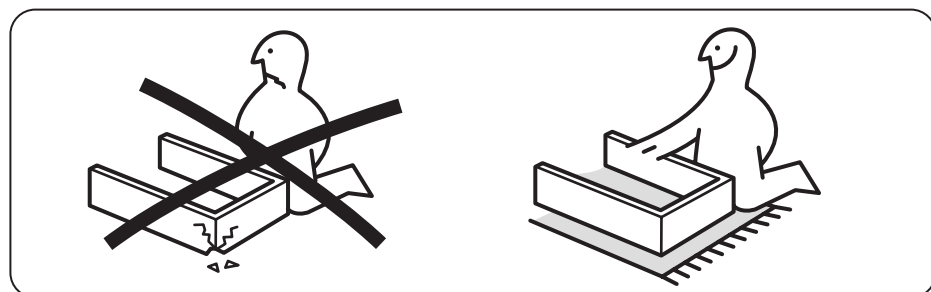
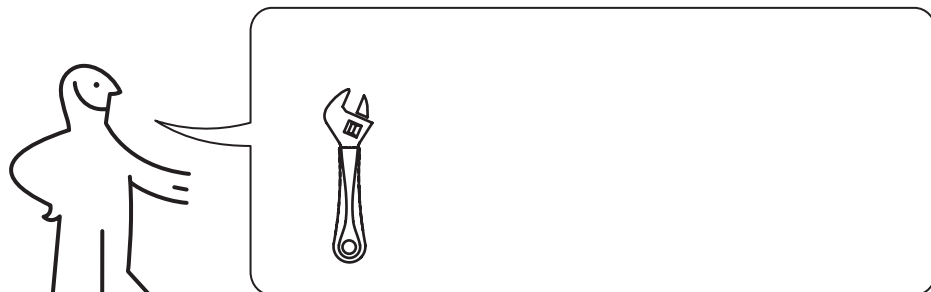

1x

100092

1

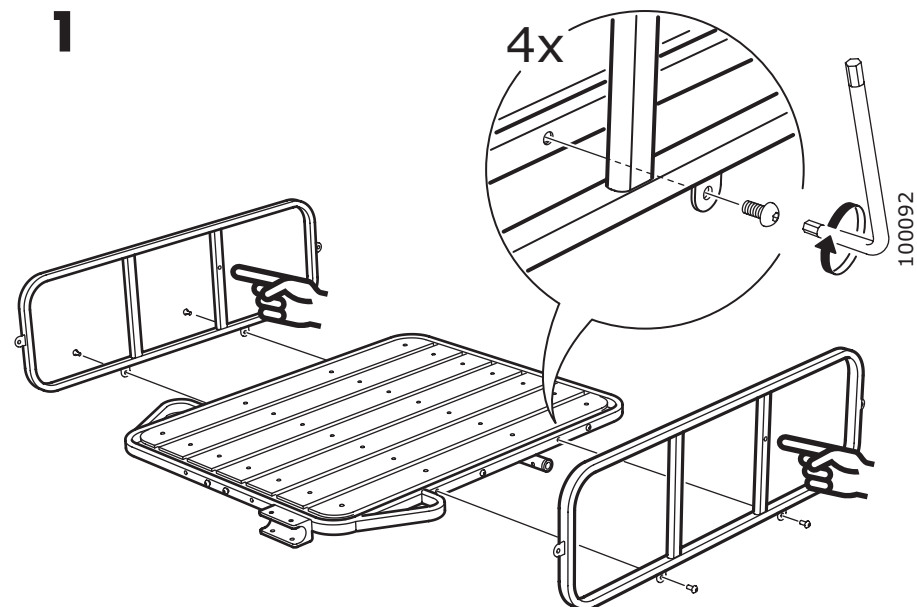

2

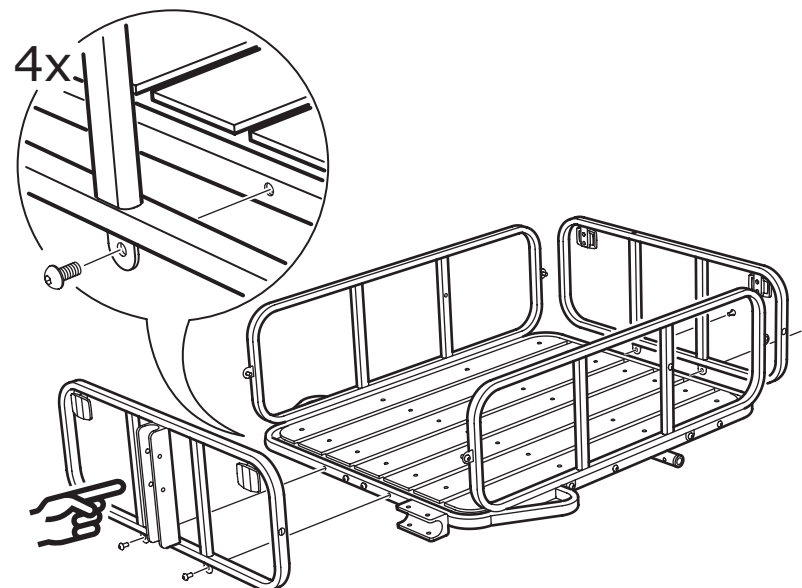

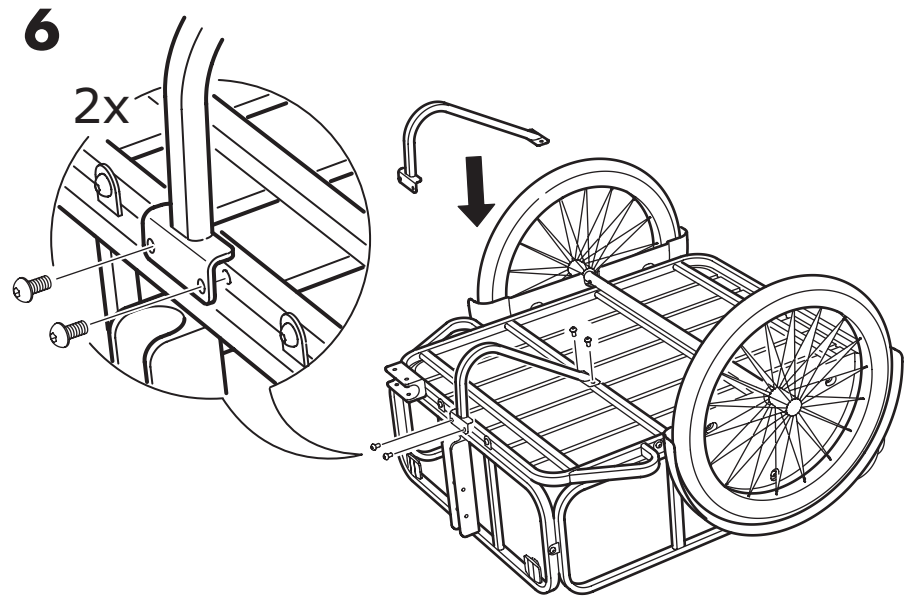
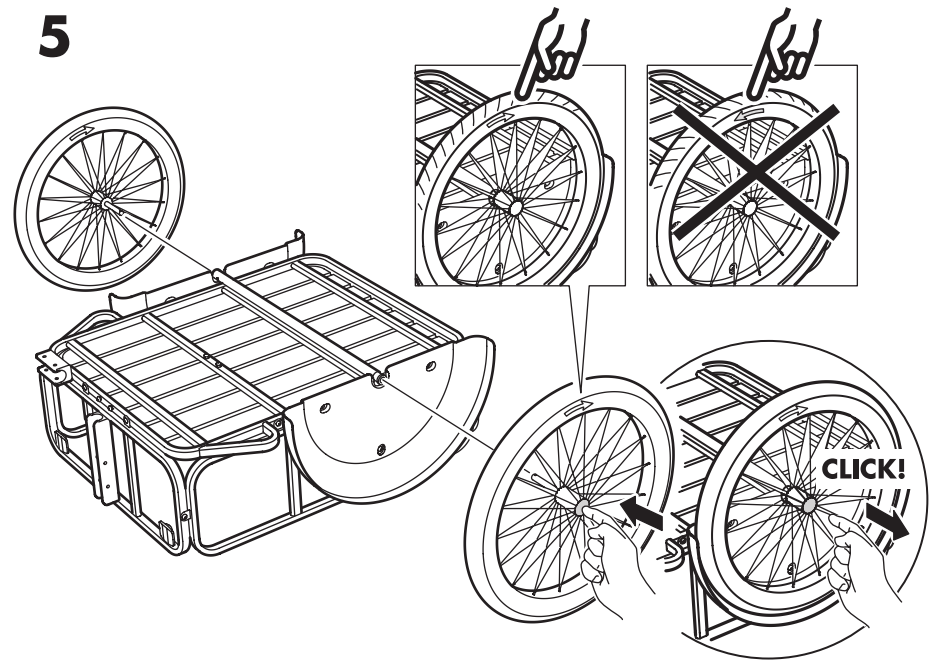
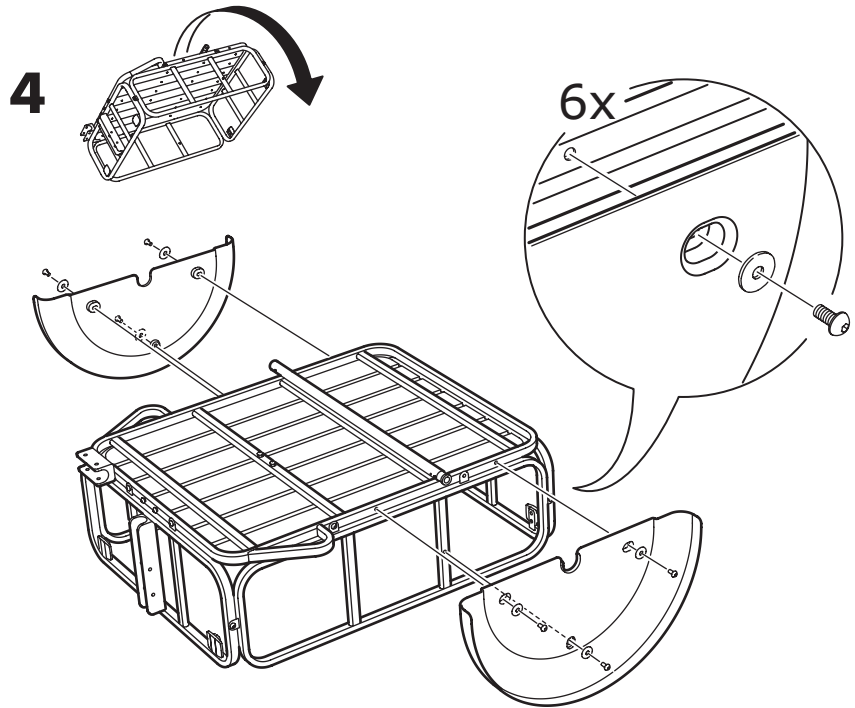
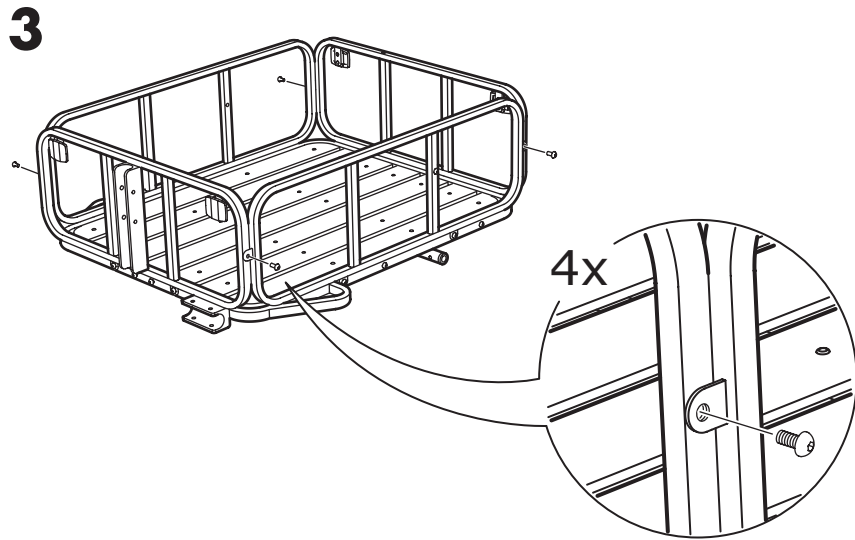

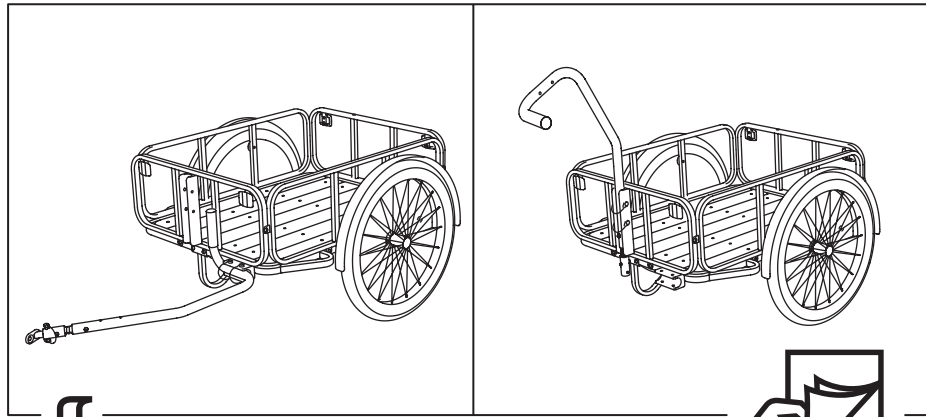

7

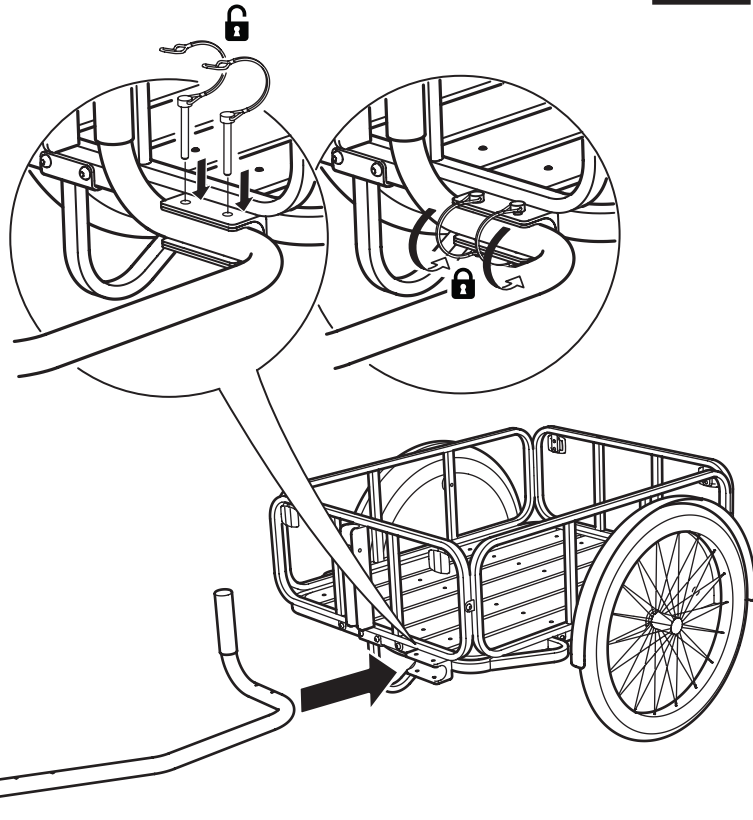

8

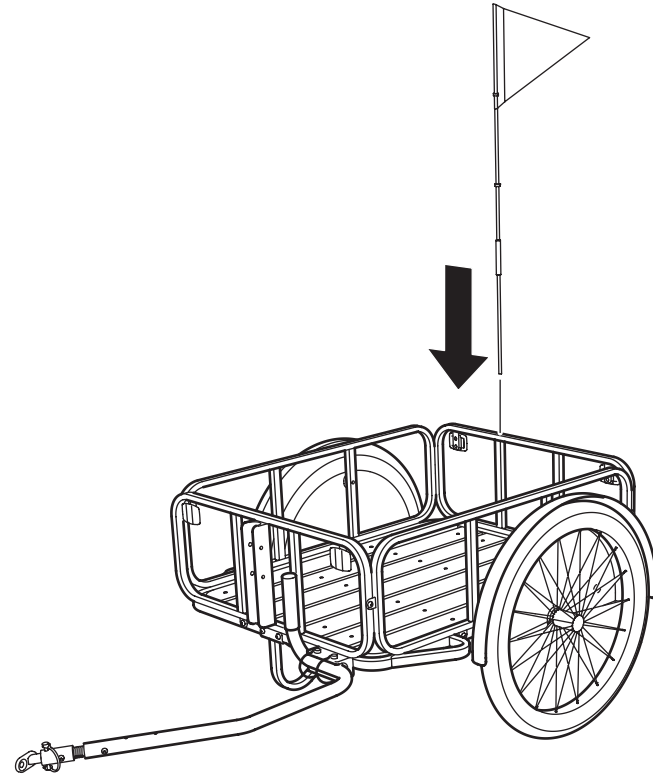

9

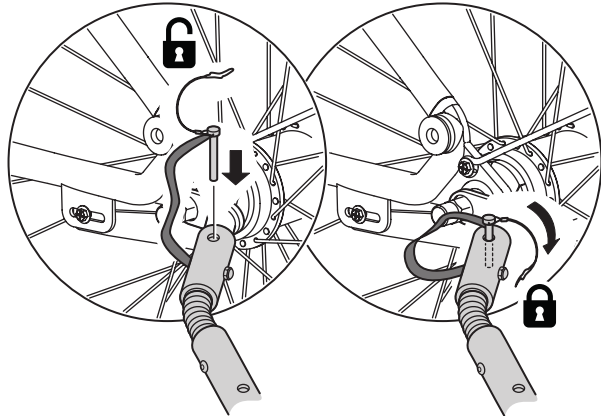
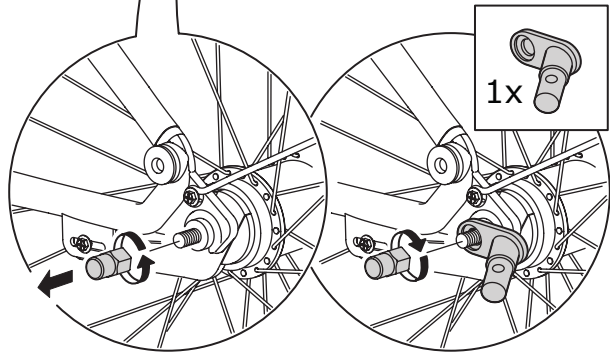
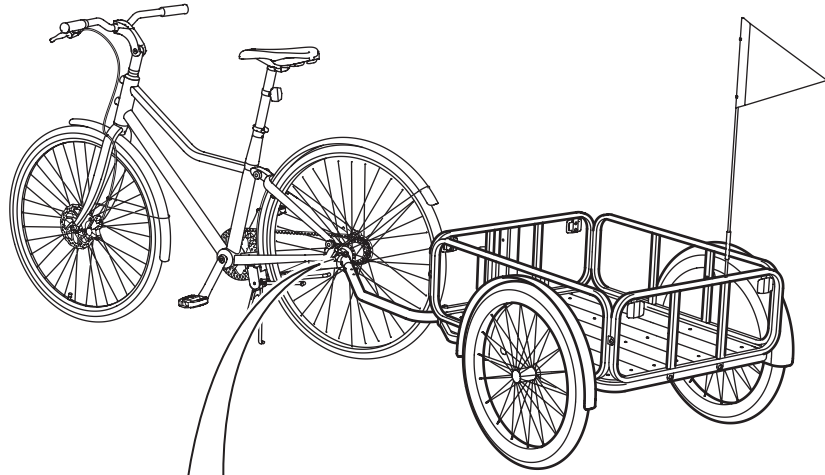

10

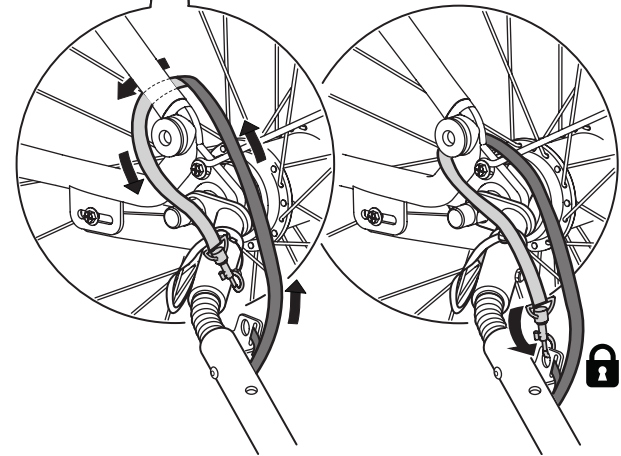
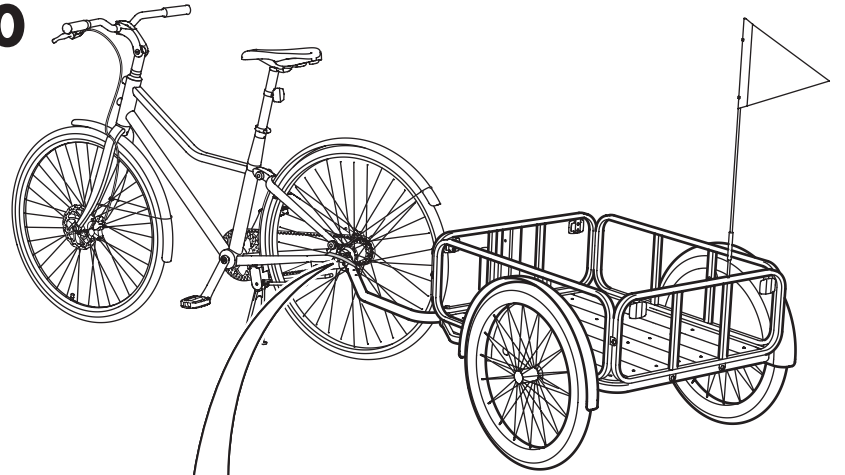

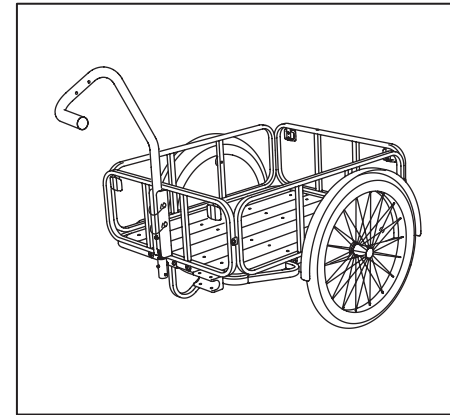
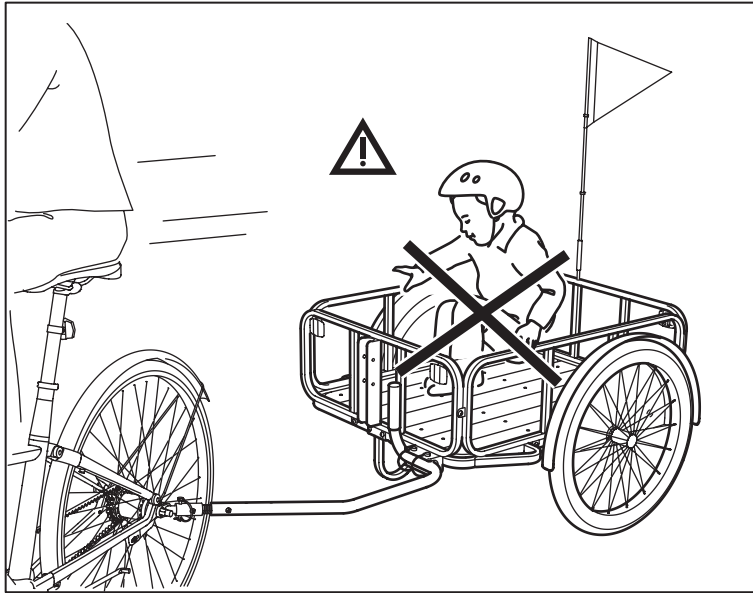

7

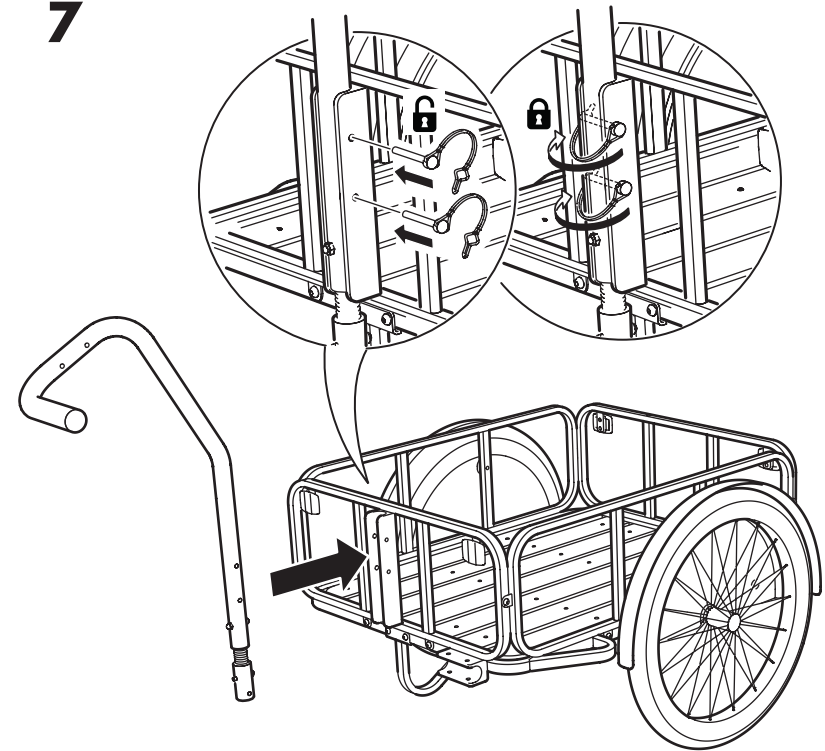

8

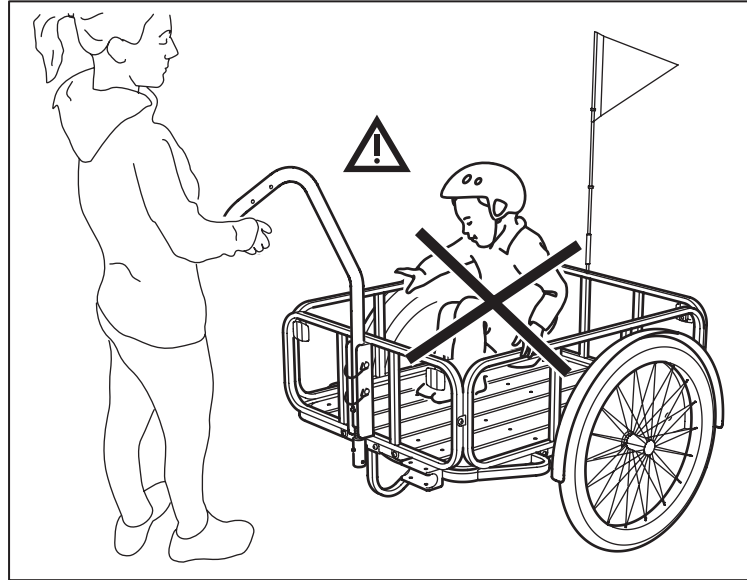
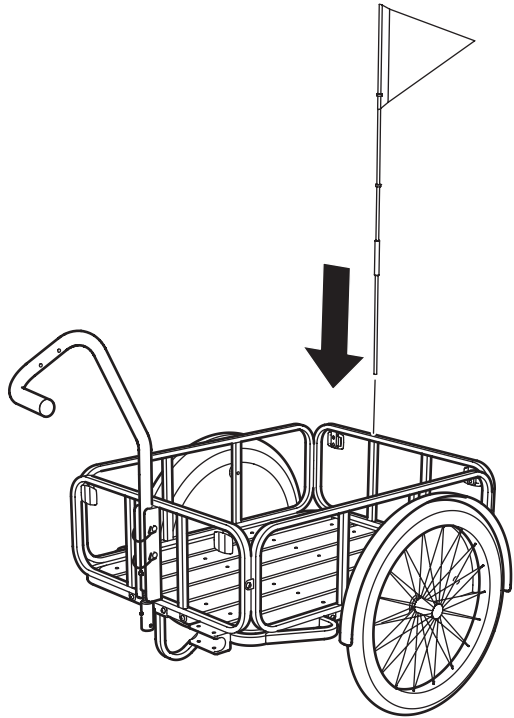



## 6. CONTROLLO DEL RIMORCHIO PRIMA DELL'USO

Prima di usare il rimorchio, effettua un controllo di sicurezza su un terreno in piano, lontano dal traffico. È importante verificare che tutti i componenti siano ben fissati e che funzionino correttamente.

### CONTROLLO DELLE GOMME

Assicurati di gonfiare le gomme alla pressione raccomandata usando una pompa con manometro. La pressione non deve superare il limite riportato sulla gomma. È preferibile utilizzare una pompa a mano o a pedale anziché il compressore di una stazione di servizio, poiché un gonfiaggio eccessivo potrebbe far scoppiare la gomma.

### CONTROLLO DEI CATARIFRANGENTI

Controlla che i catarifrangenti siano posizionati correttamente.



**AVVERTENZE!** *Come tutti i componenti meccanici, il rimorchio per bicicletta è soggetto a usura. I vari materiali e componenti possono reagire in modo diverso all'usura. I componenti che hanno superato il periodo di durata previsto potrebbero rompersi, provocando lesioni a chi utilizza la bicicletta. Eventuali spaccature, graffi o alterazioni del colore in aree soggette a forte usura indicano che il componente ha raggiunto la propria durata massima e deve essere sostituito.*

ÍNDICE

1. AVISO	58
2. SEGURANÇA	58
3. CUIDADO E MANUTENÇÃO	58
4. PEÇAS E COMPONENTES	59
5. MONTAR O SEU ATRELADO	60
6. TESTAR O SEU ATRELADO ANTES DE UTILIZAR	66

1. ATENÇÃO!



- **ATENÇÃO!** A distância de travagem aumenta com um atrelado.
- Adequado à bicicleta SLADDA de 26" e 28".
- **ATENÇÃO!** Caso pretenda usar este atrelado com uma bicicleta diferente, certifique-se de que verifica o manual da bicicleta para saber quais as ferragens e atrelados adequados. Tenha em atenção! Nunca coloque o atrelado numa bicicleta de montanha, numa bicicleta de corrida, numa bicicleta elétrica ou qualquer outra com auxílio de motor.
- O atrelado SLADDA não é adequado ao transporte de crianças nem de animais. Siga o manual para a montagem e utilize o atrelado de uma forma correta e segura.

2. SEGURANÇA

Para sua própria segurança, siga sempre as regras de trânsito do seu país.

3. LIMPEZA E MANUTENÇÃO

Certifique-se de que verifica com regularidade os componentes do atrelado, como parafusos de montagem, ferragens, estrutura, refletores e pneus.

IKEA of Sweden AB  
34381 Älmhult  
Sweden

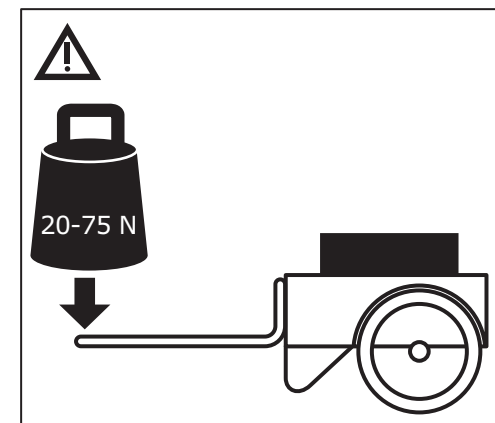
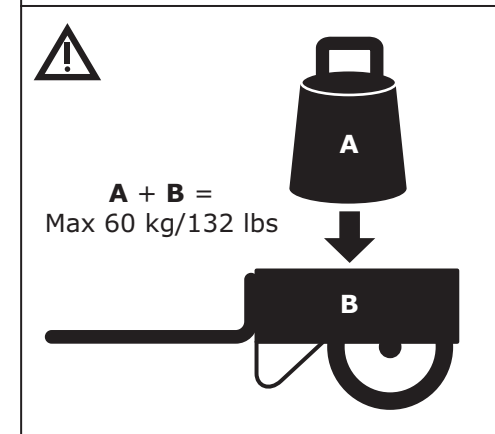
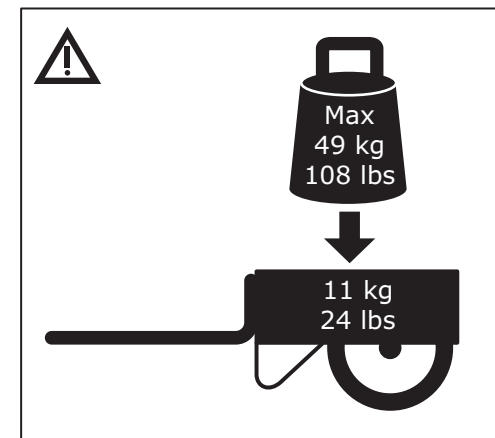

#### 4. PEÇAS E COMPONENTES

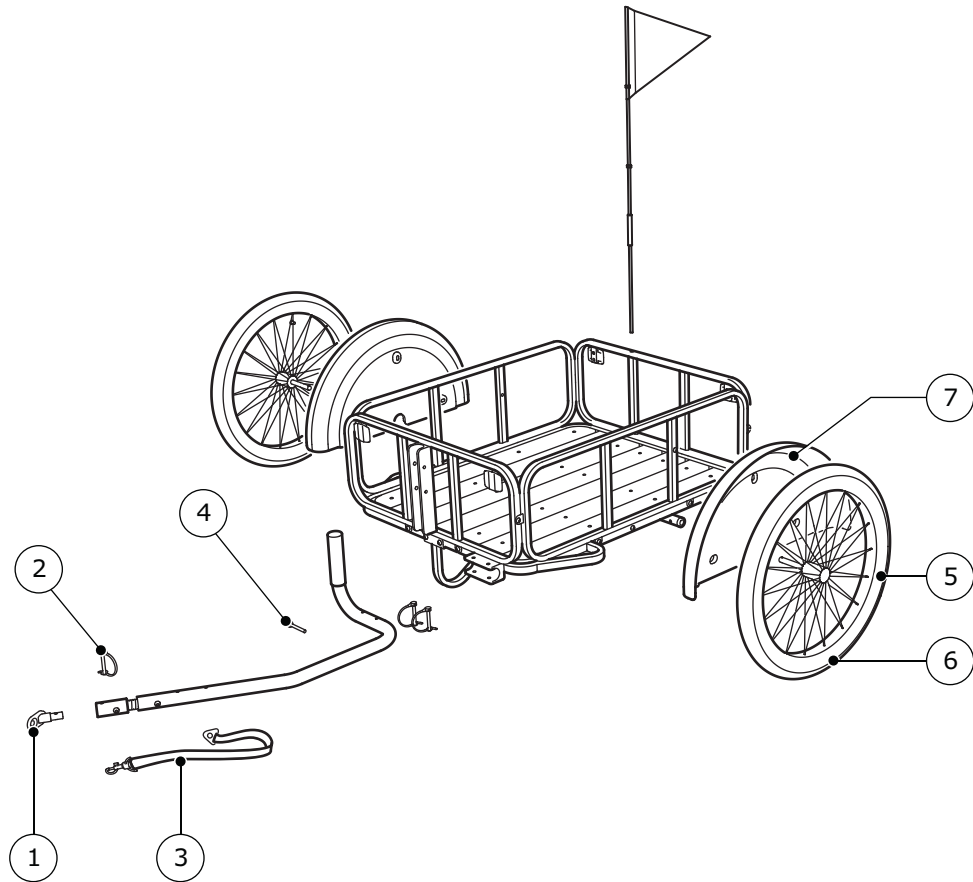

- 1 Conetor (152921)
- 2 Anilha em D (152922)
- 3 Correia de segurança (152923)
- 4 Parafuso M5 (152924)
- 5 Pneu, câmara-de-ar (152925)
- 6 Pneu (152926)
- 7 Guarda-lamas (152927)

## 5. MONTAR O SEU ATRELADO

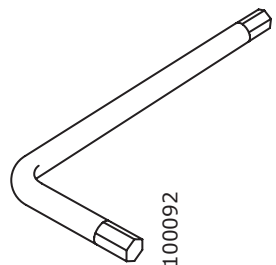
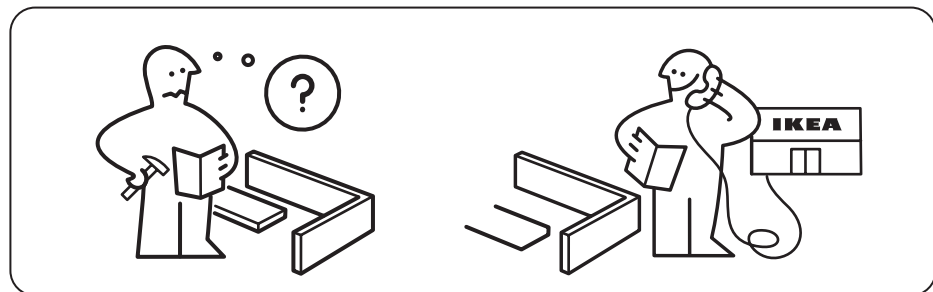
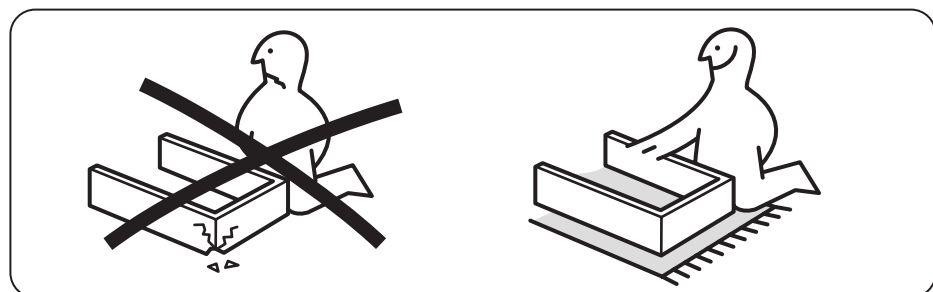
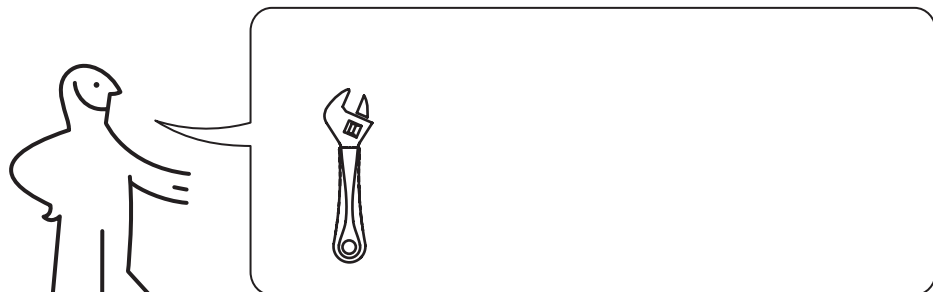

100092

1x

1

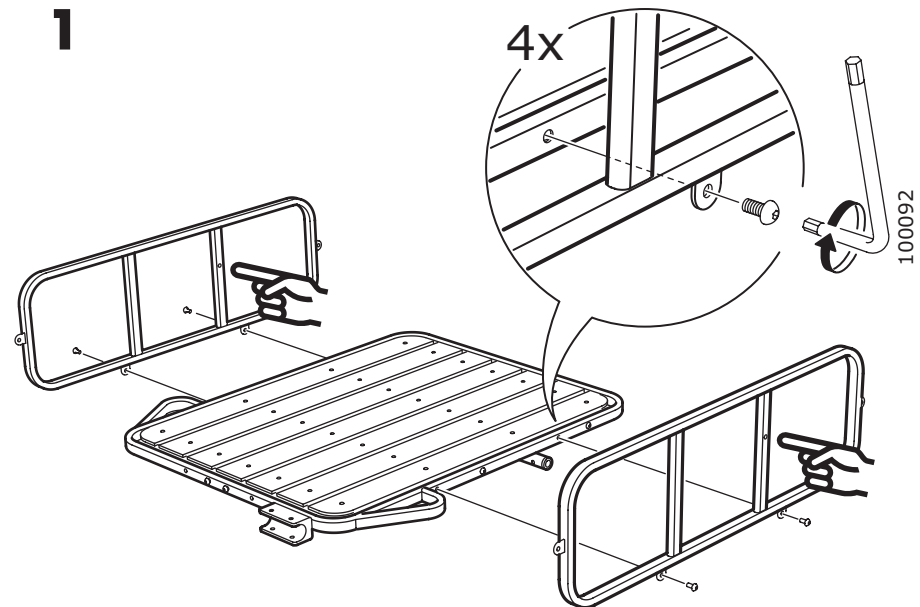

2

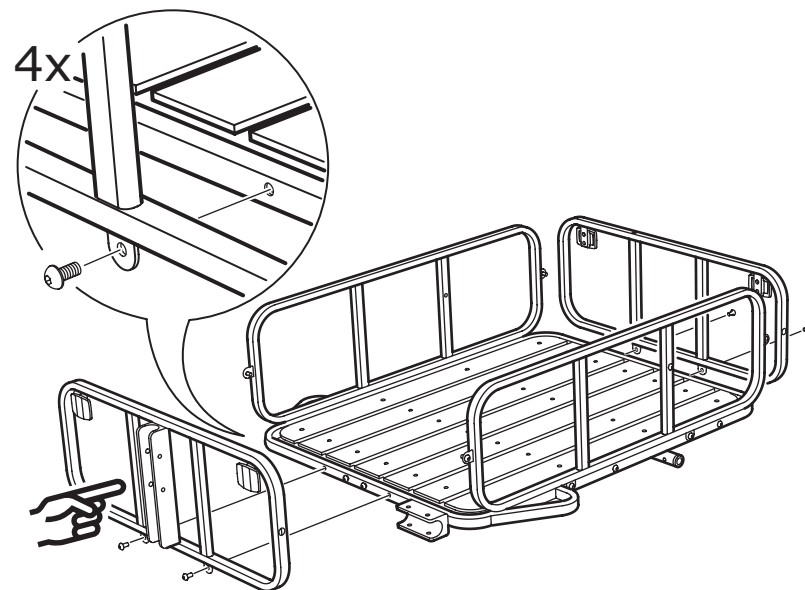

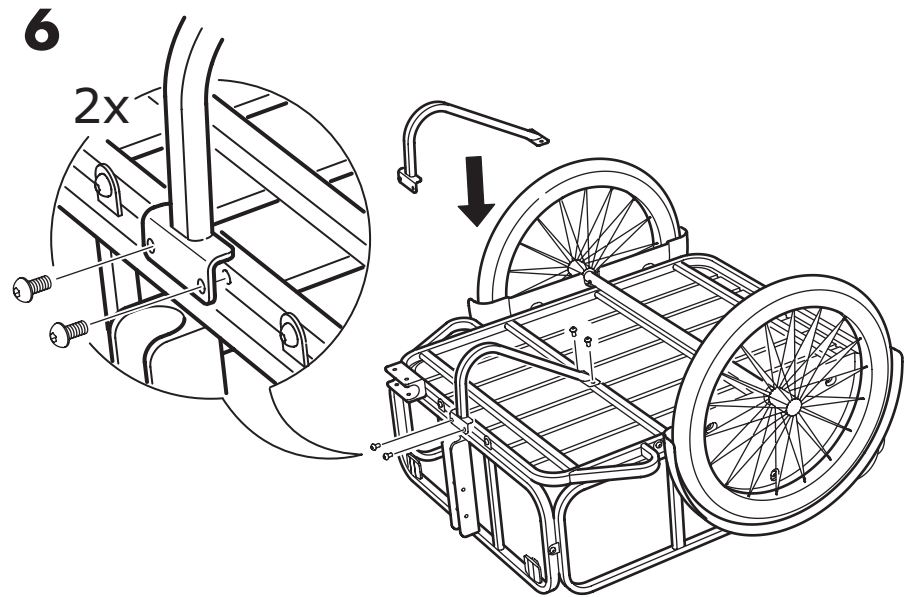
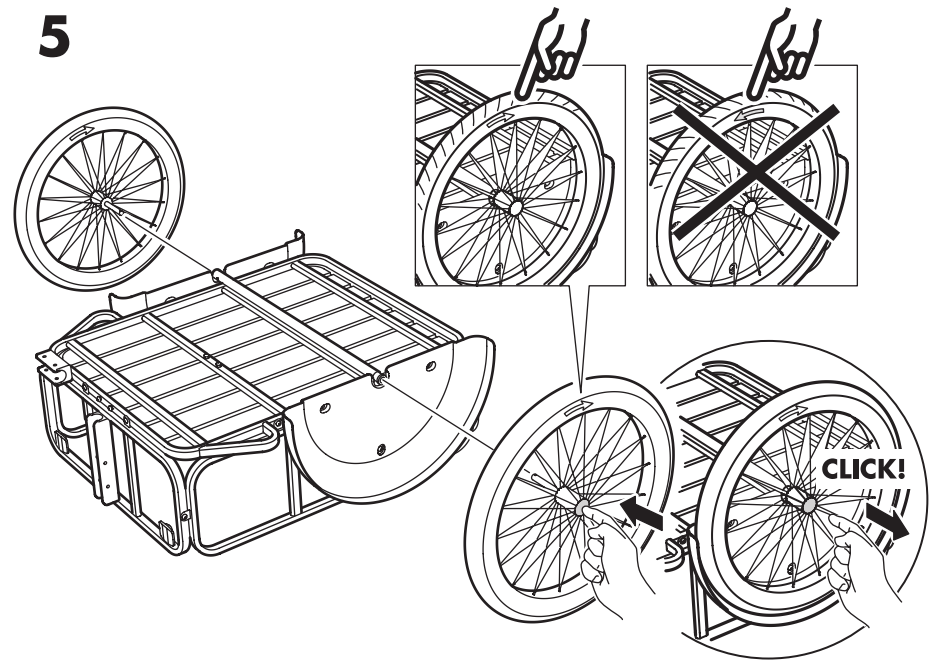
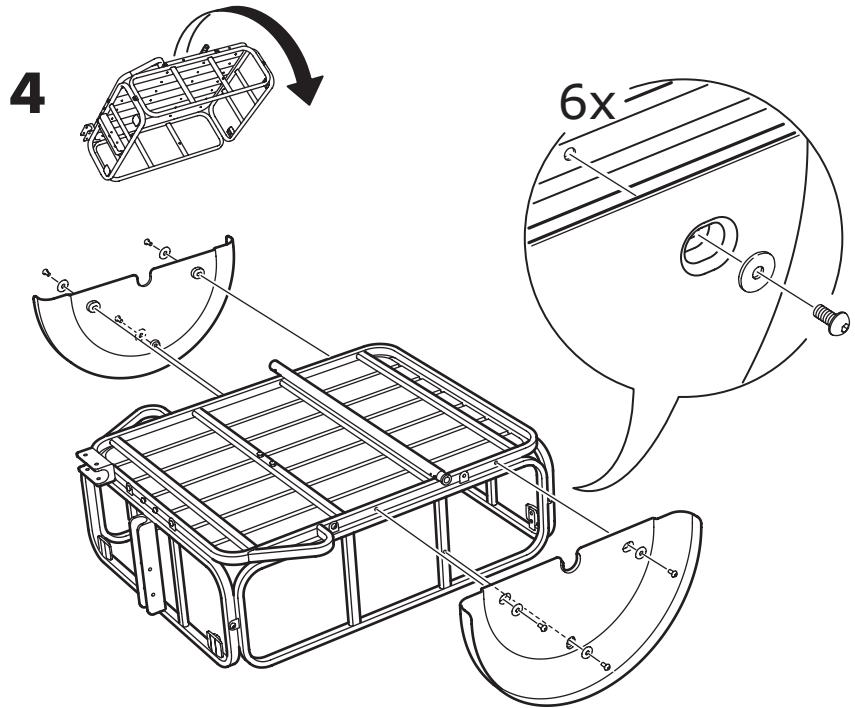
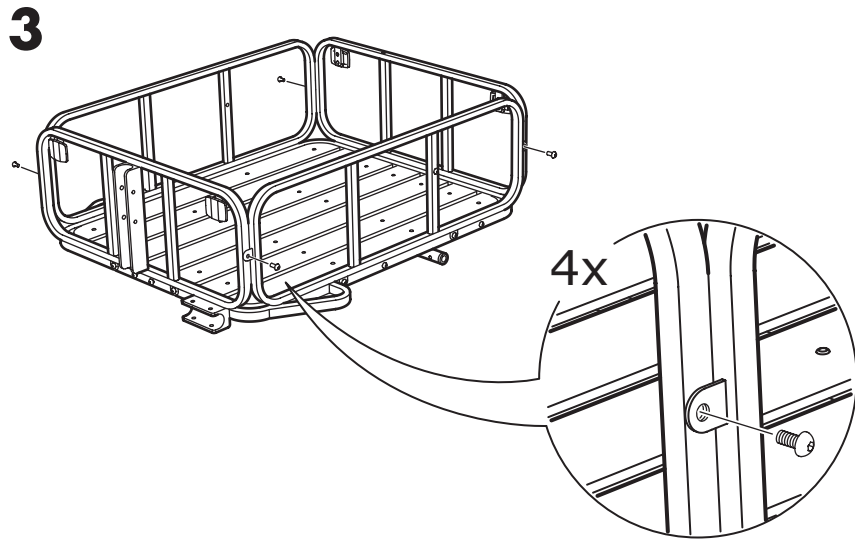

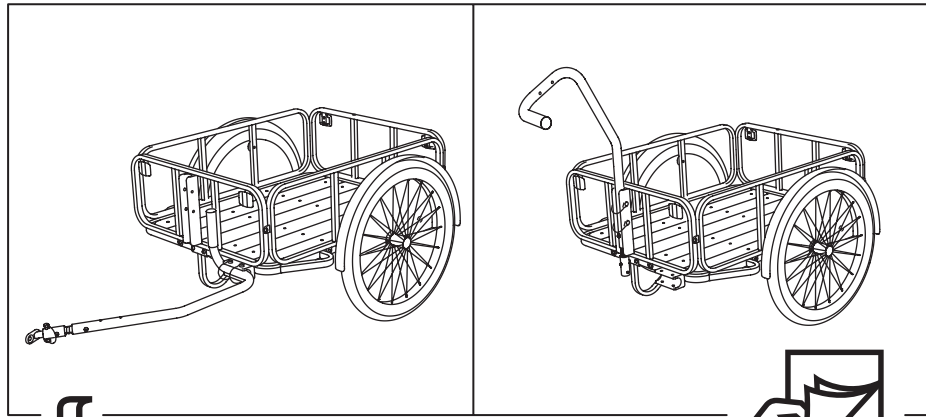

7

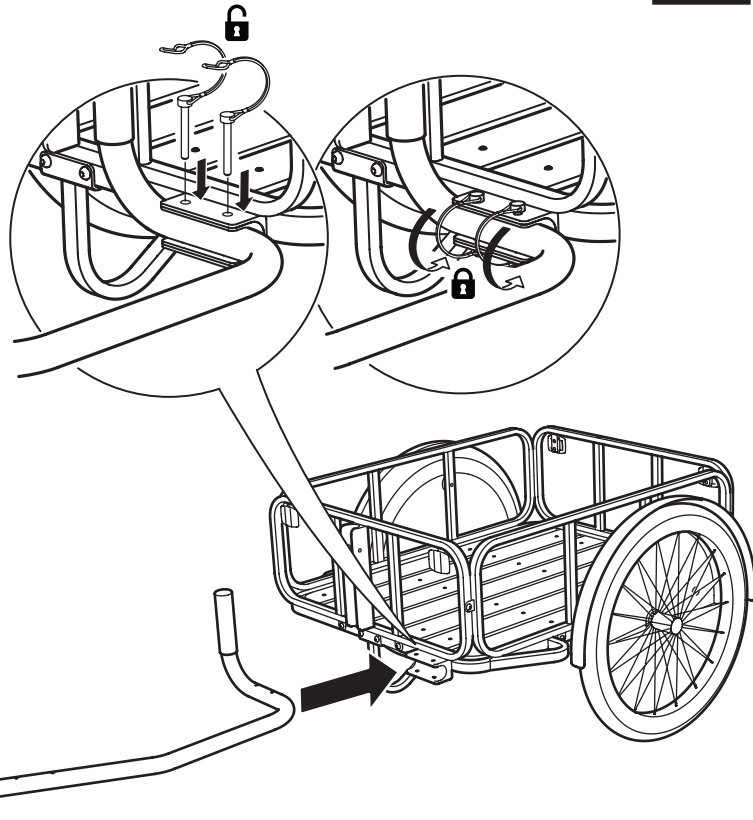

8

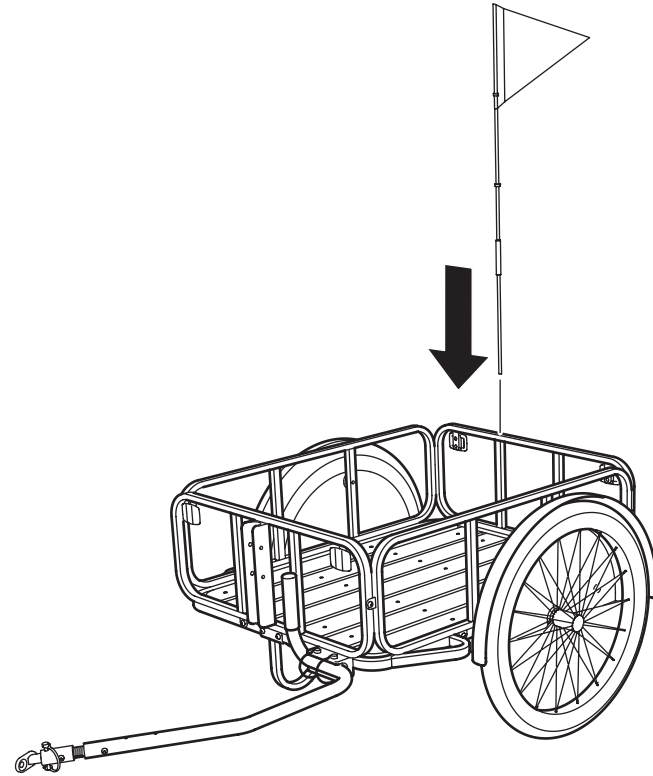

9

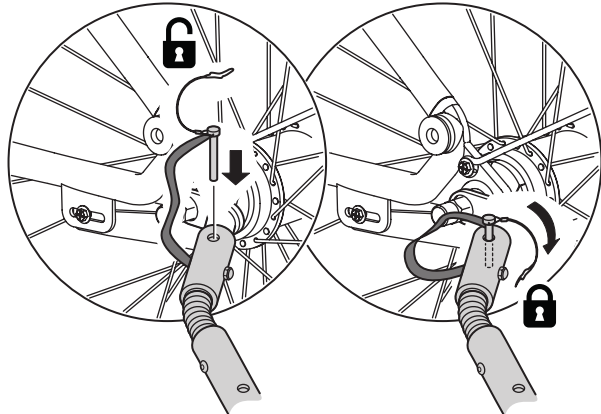
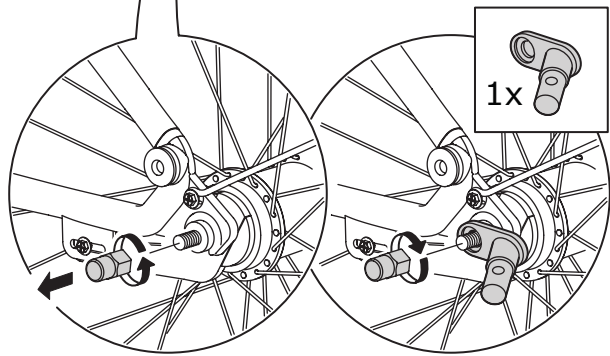
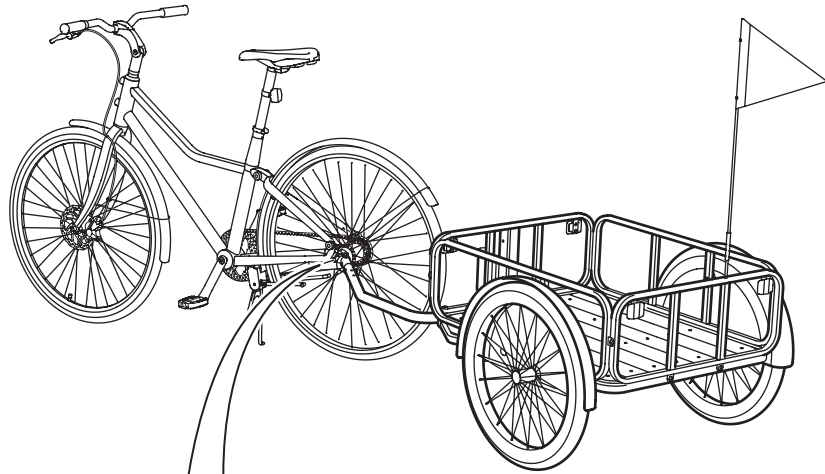

10

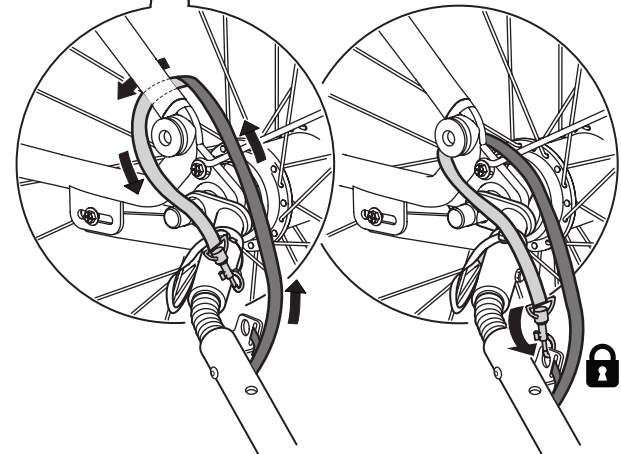
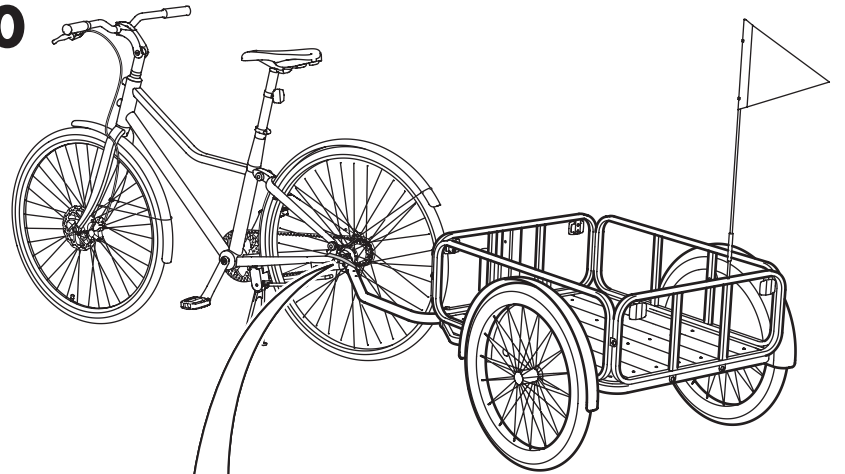

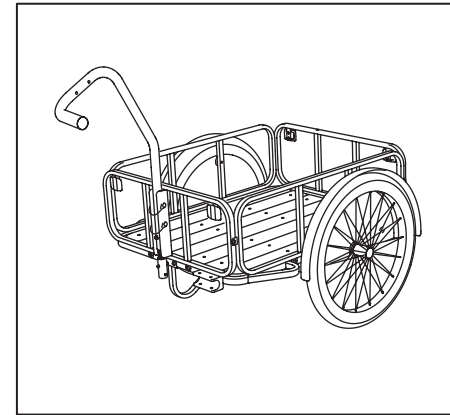
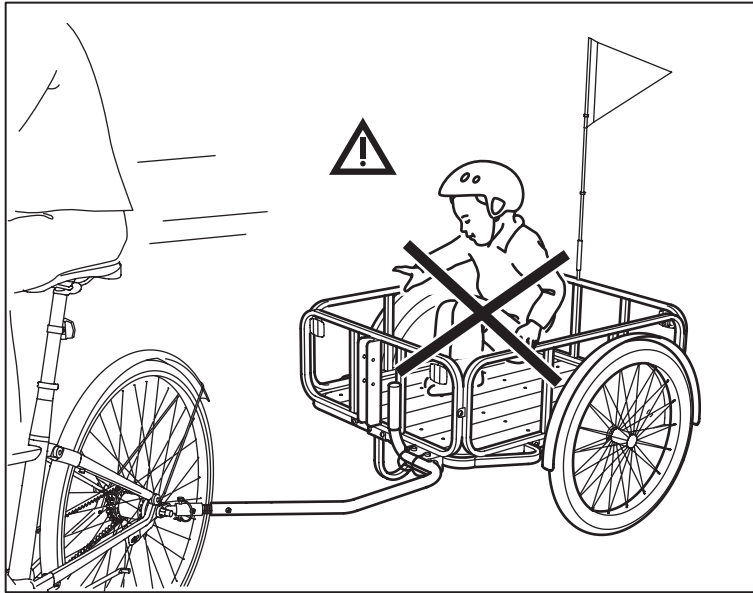

7

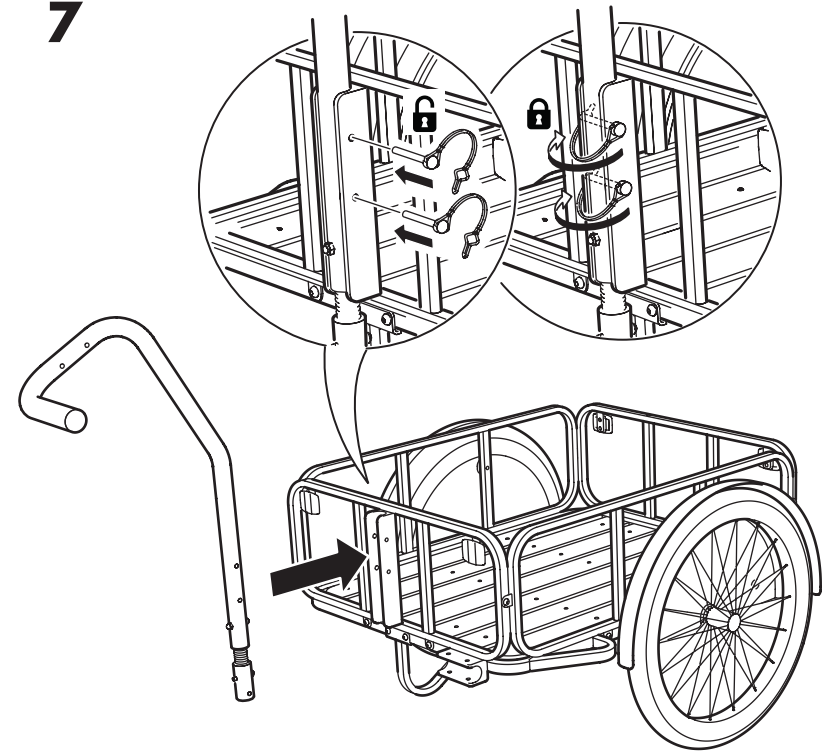



8

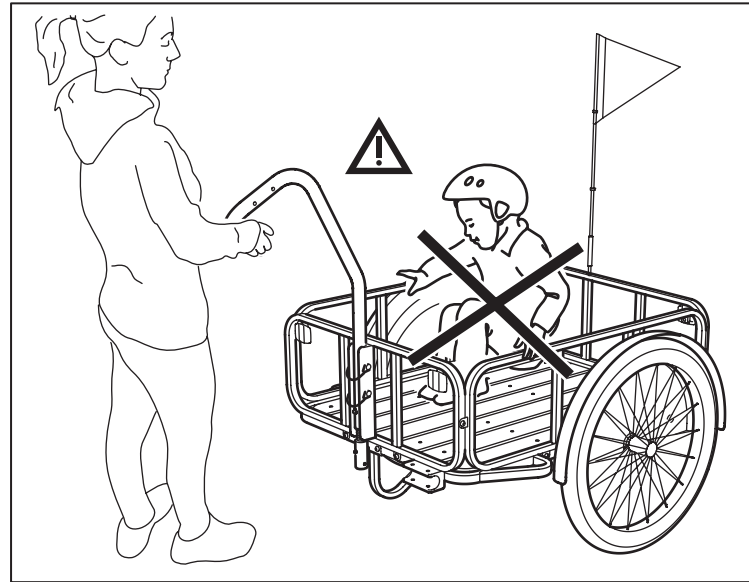
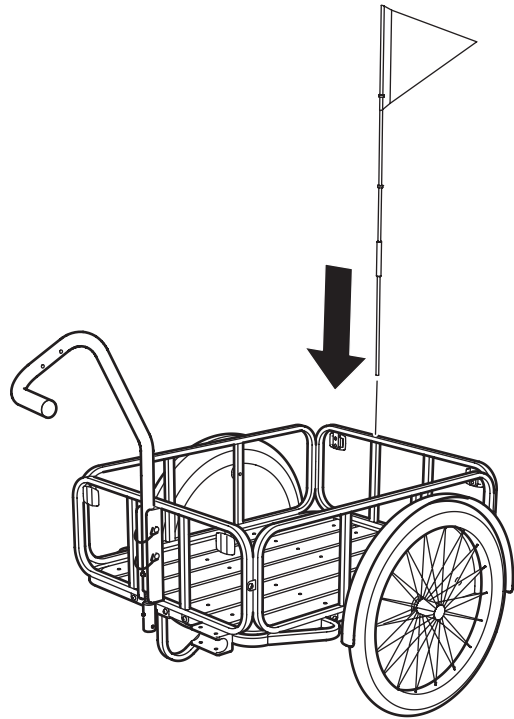

## 6. TESTAR O SEU ATRELADO ANTES DE UTILIZAR

Antes de usar o seu atrelado deve realizar uma verificação de segurança em terreno plano e longe de muito movimento. É importante garantir que todas as peças estão bem apertadas e a funcionar adequadamente.

### VERIFIQUE OS PNEUS

Certifique-se de que os pneus estão cheios de acordo com o limite de pressão recomendada, usando uma bomba com manómetro. A pressão não deve ultrapassar o limite recomendado, conforme indicado no pneu. É melhor usar uma bomba de mão ou de pé em vez das bombas das estações de serviço, uma vez que, se encher demasiado, o pneu pode rebentar.

### CHECK REFLECTORS

#### VERIFIQUE OS REFLETORES

Verifique se os refletores estão posicionados corretamente.



**AVISO!** Como com todos os componentes mecânicos, o atrelado está sujeita ao desgaste e a uma grande pressão. Materiais e componentes diferentes podem reagir ao uso ou ao desgaste de formas diferentes. Se a vida útil prevista de um componente for ultrapassada, pode, de repente, falhar, causando ferimentos no ciclista. Qualquer tipo de rachas, riscos ou alteração de cor em área de muito uso, indicam que foi atingido o fim de vida útil do componente e deve ser substituído.

