

SLADDA

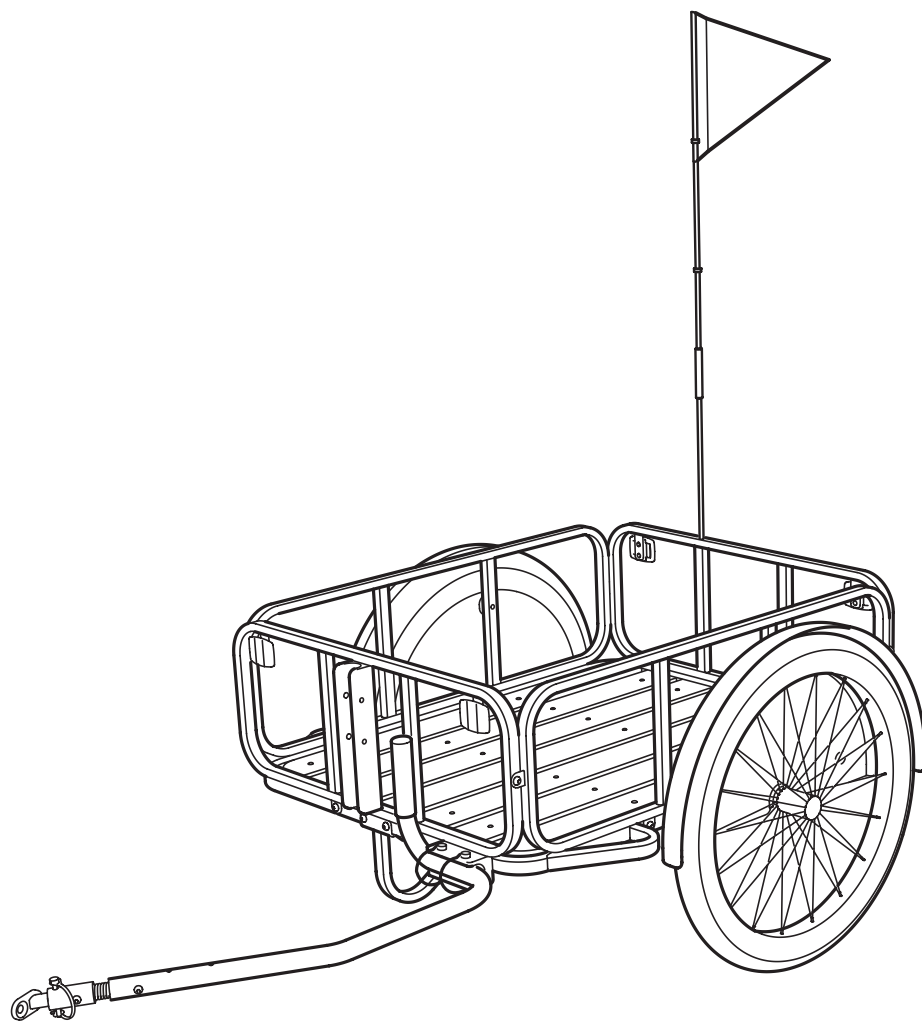

Design and Quality
IKEA of Sweden

ENGLISH	4
DEUTSCH	13
FRANÇAIS	22
NEDERLANDS	31
NORSK	40
ITALIANO	49
ΕΛΛΗΝΙΚΑ	58

ENGLISH

CONTENTS

1. WARNING	4
2. SAFETY	4
3. CARE AND MAINTENANCE	4
4. TRAILER PARTS & COMPONENTS	5
5. ASSEMBLE YOUR TRAILER	6
6. TEST YOUR TRAILER	12

1. WARNING



- **Warning!** Your braking distance will increase when biking with a trailer.
- Fits SLADDA bicycle 26" and 28".
- **NOTE!** If you want to use this trailer with a different bicycle, make sure to check the bicycle manual for suitable fittings and trailers. Please note! Never connect the trailer to a mountain bike, racing bike, e-bike or any other bicycle that has motor assistance.
- SLADDA trailer is not suitable for transporting children or animals. Follow the manual to assemble and use the trailer in a correct and safe way.

2. SAFETY

For your own safety, always follow the traffic rules in your country.

3. CARE AND MAINTENANCE

Make sure to check the trailer components, such as assembly screws, fittings, frame, reflective and tyres regularly.

IKEA of Sweden AB
34381 Älmhult
Sweden

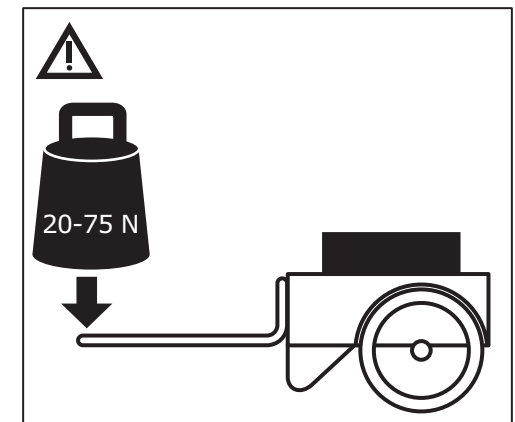
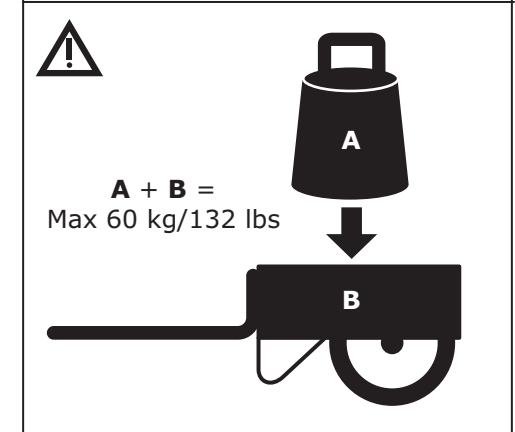
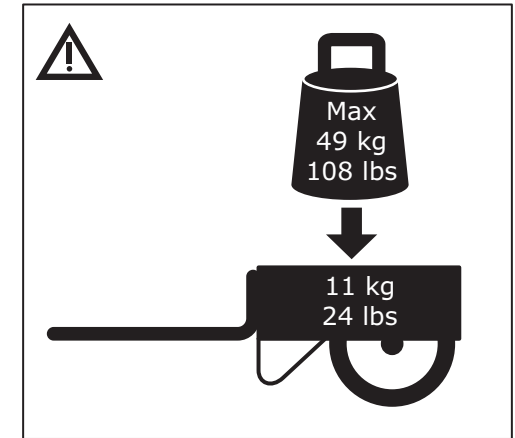

4. TRAILER PARTS & COMPONENTS

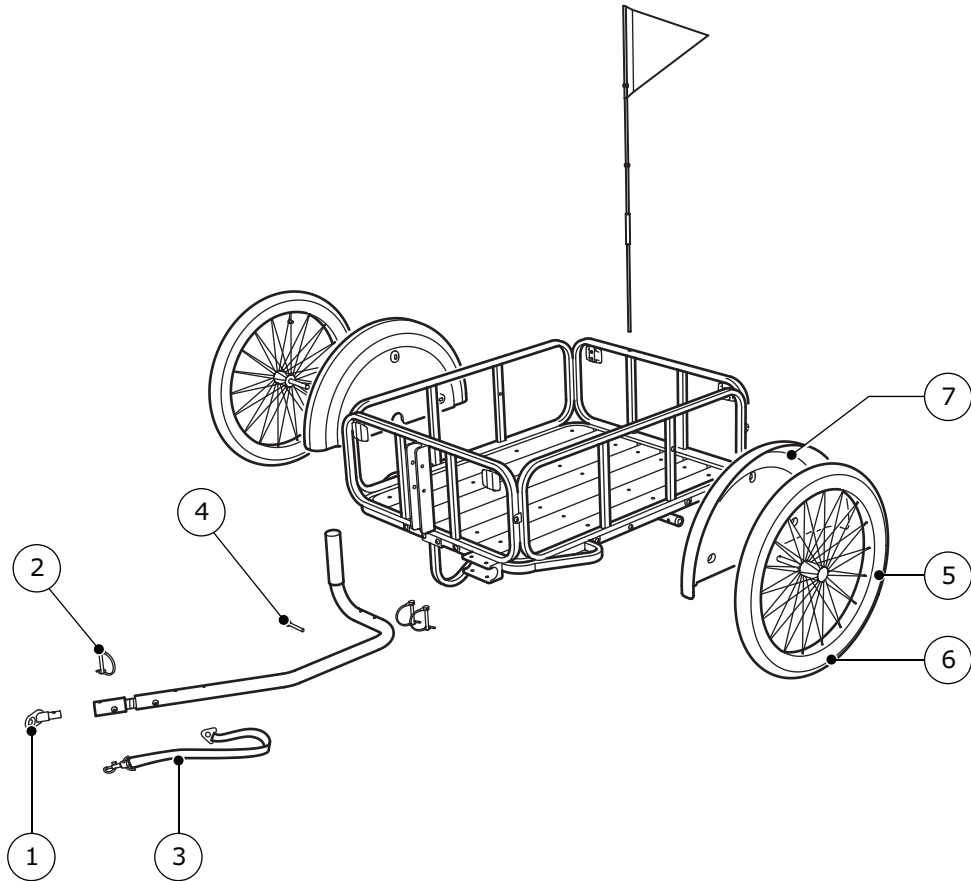

- 1 Connector (152921)
- 2 D-shape locker (152922)
- 3 Safety strap (152923)
- 4 M5 Screw (152924)
- 5 Tire, inner tube (152925)
- 6 Tire (152926)
- 7 Fender (152927)

5. ASSEMBLE YOUR TRAILER

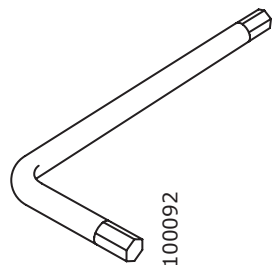
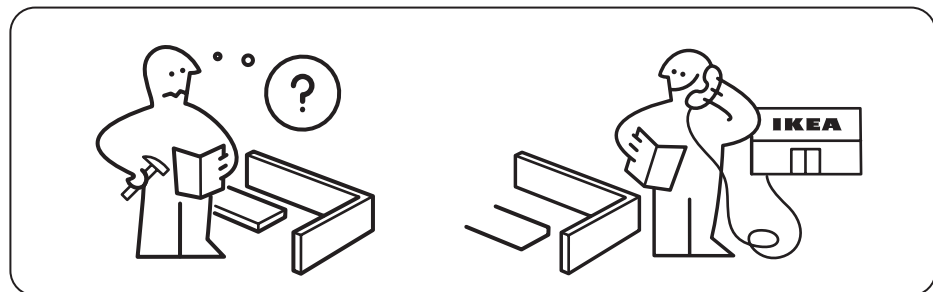
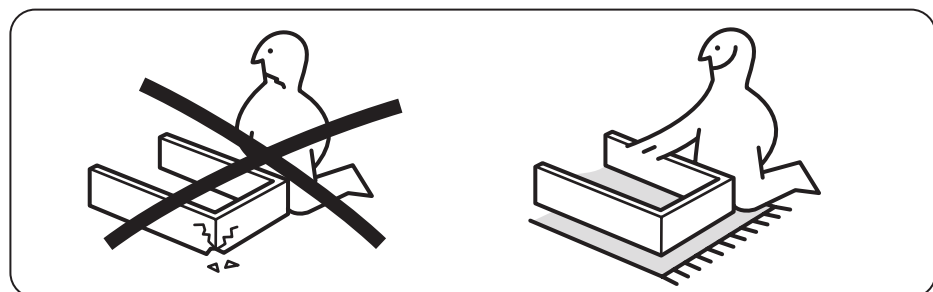
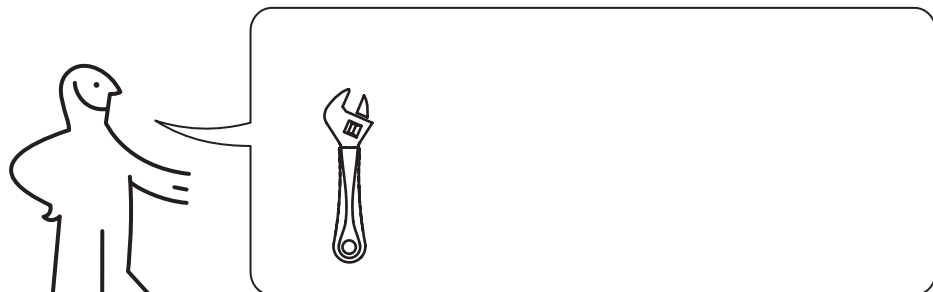

100092

1x

6

1

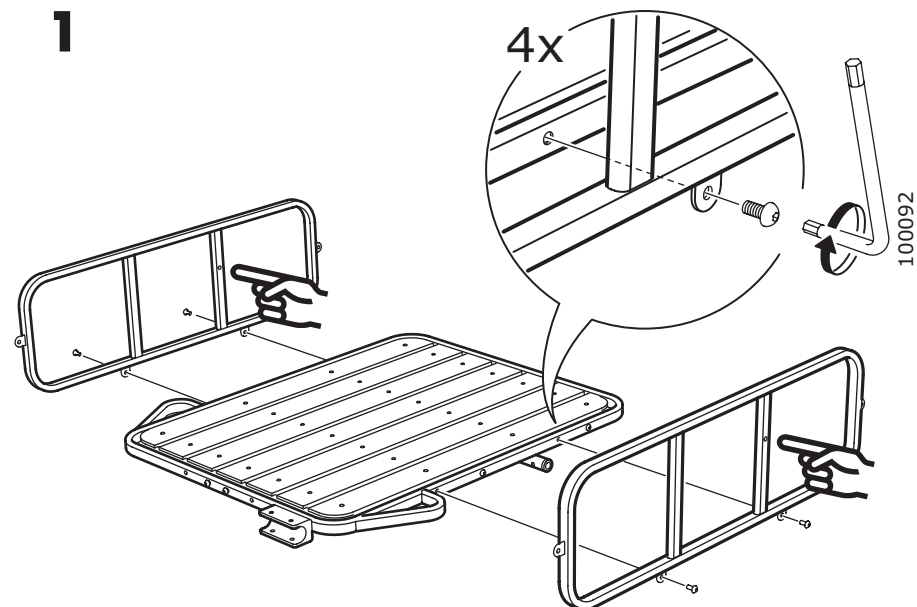

2

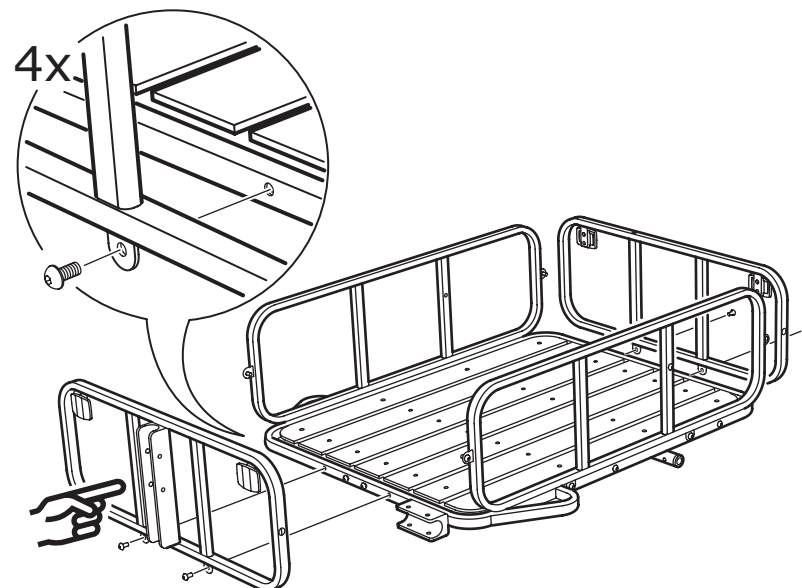

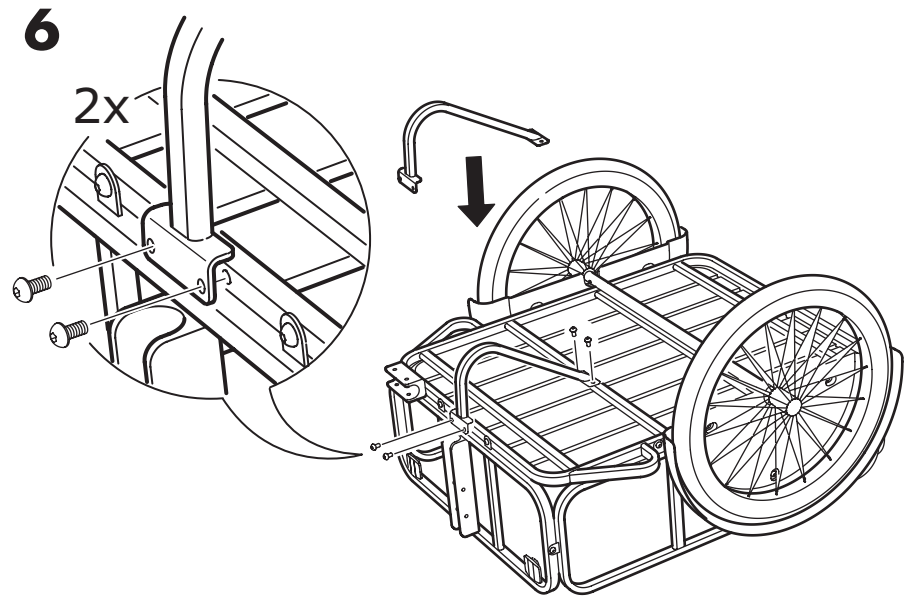
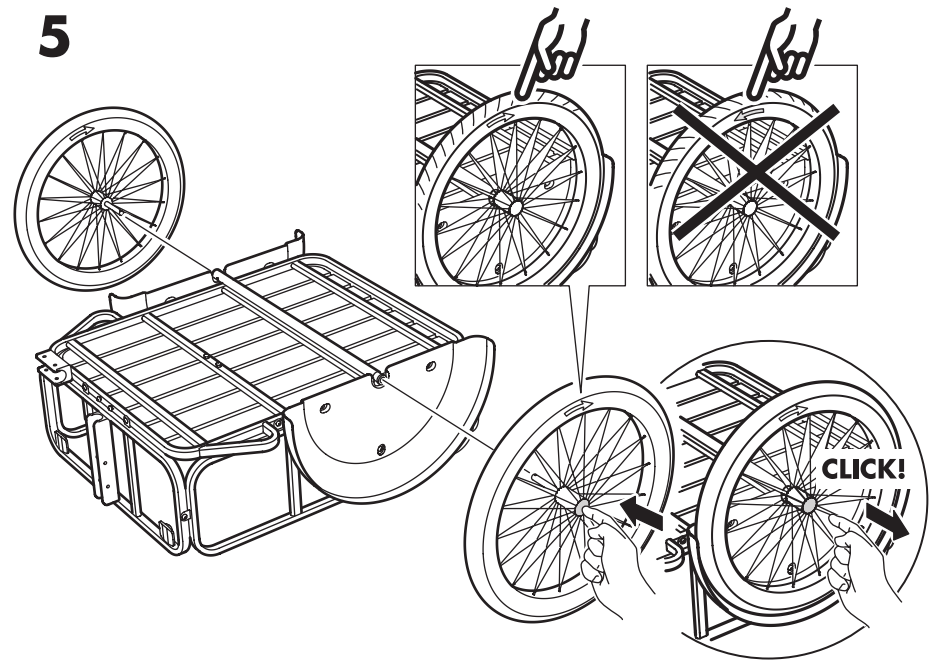
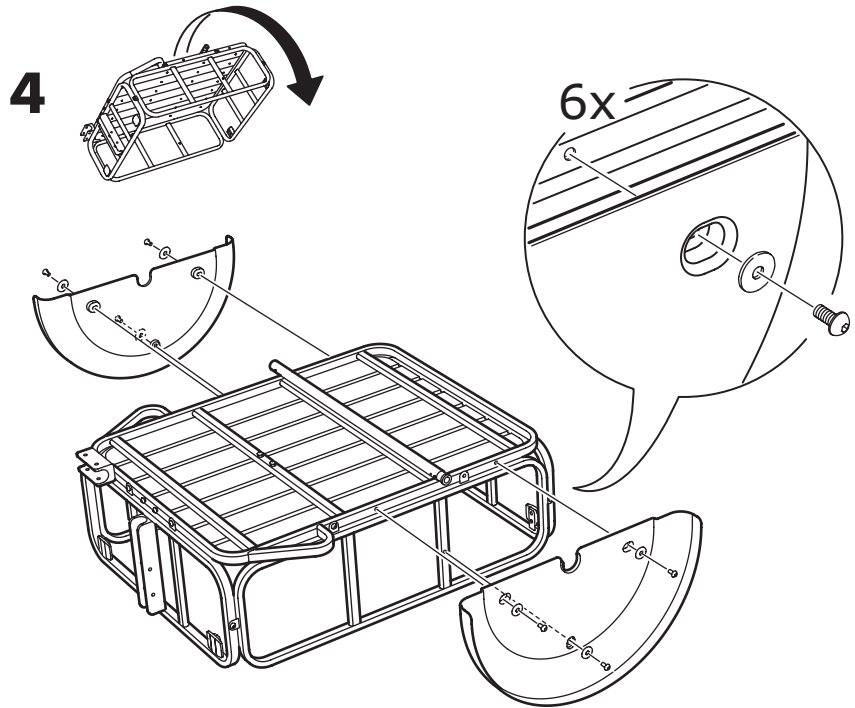
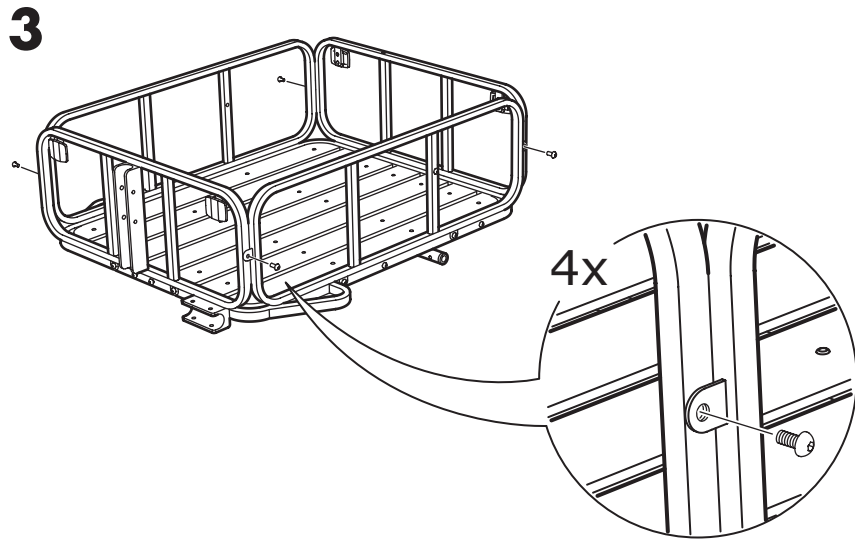

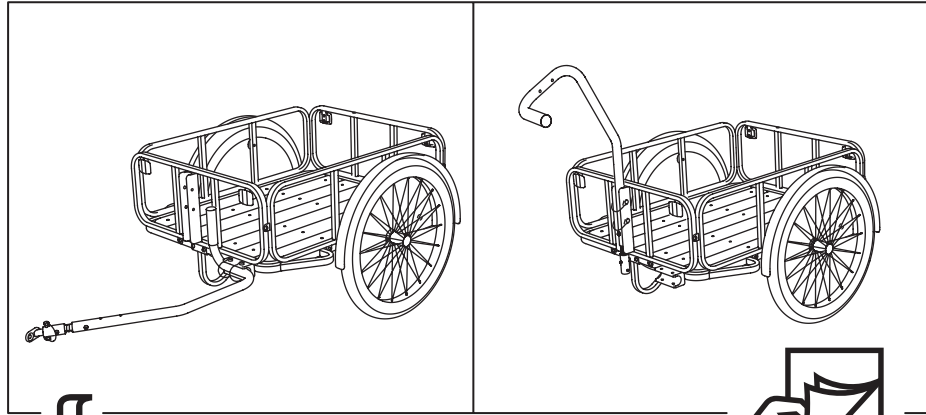

7

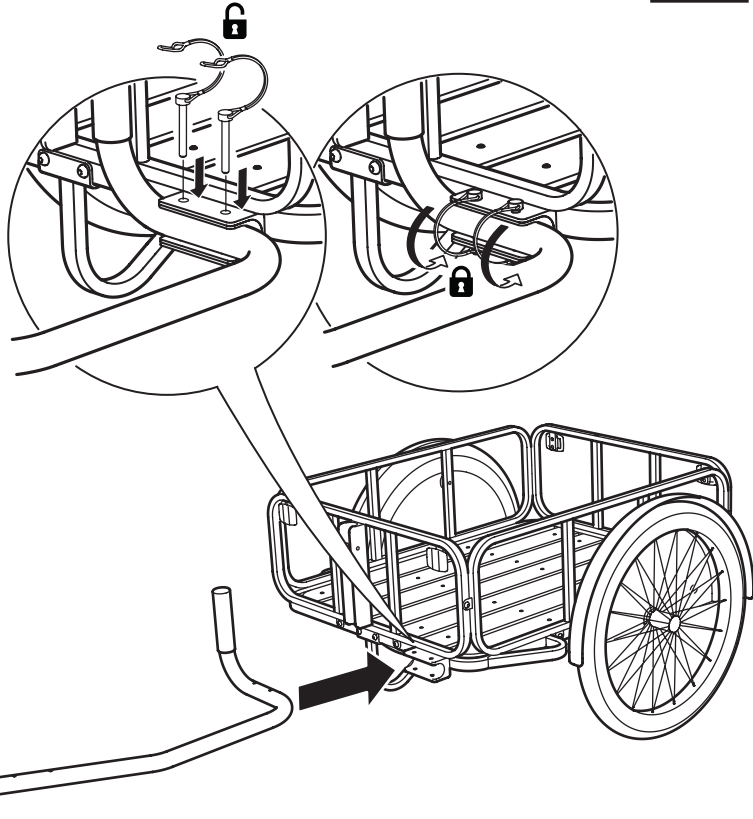

8

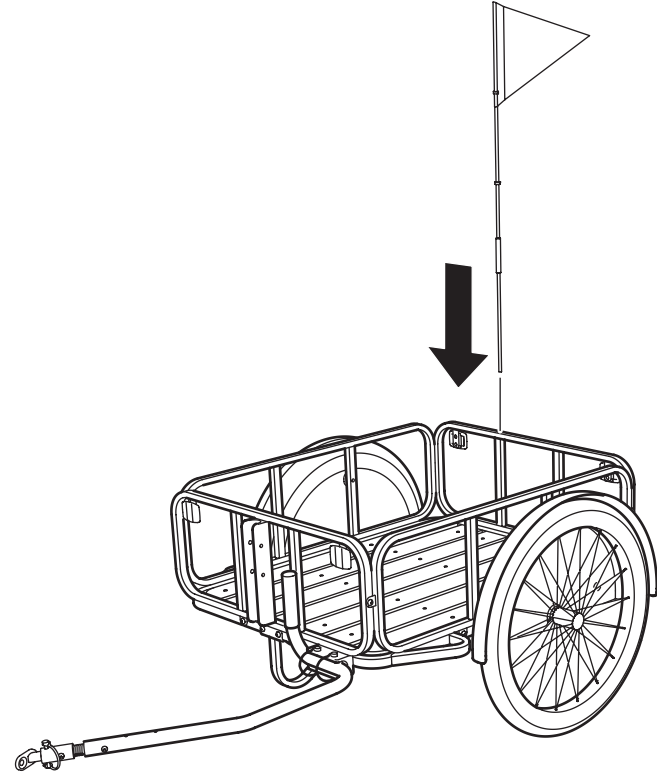

9

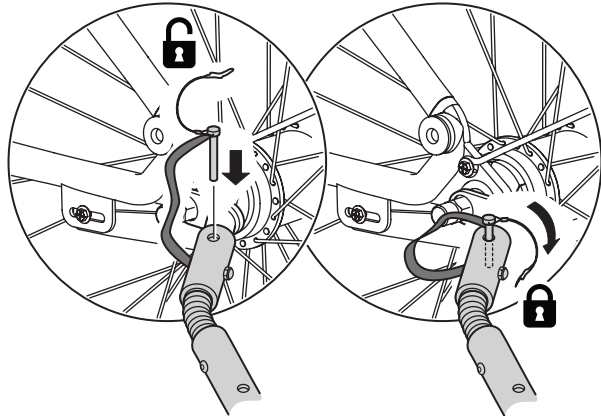
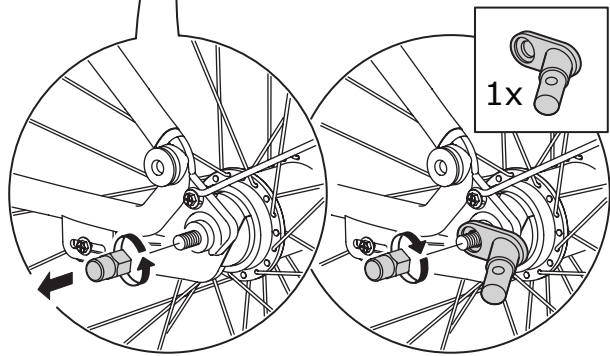
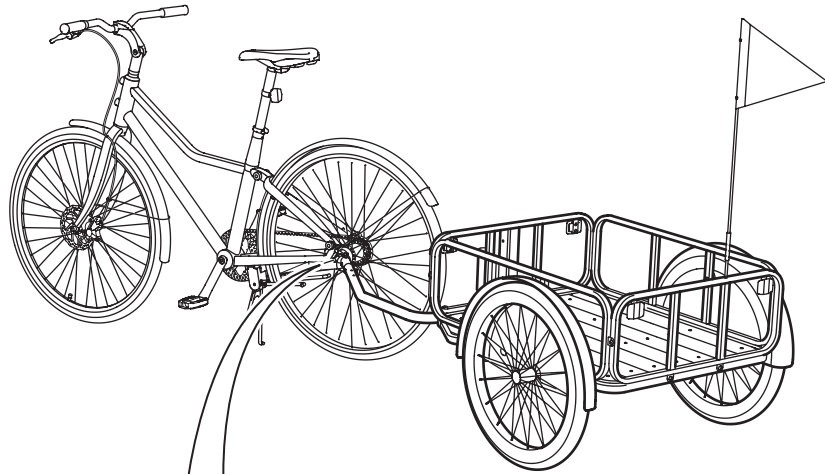

10

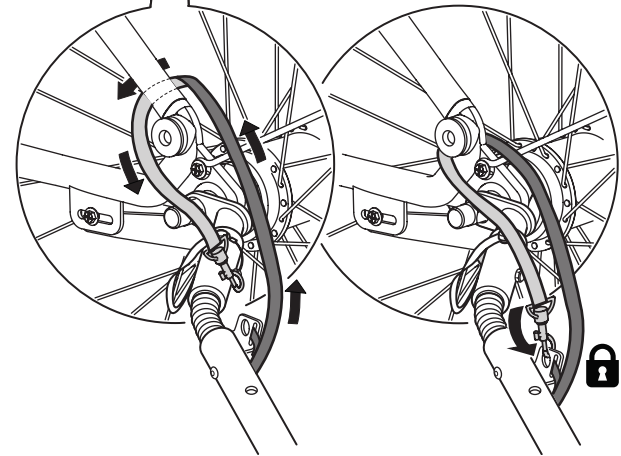
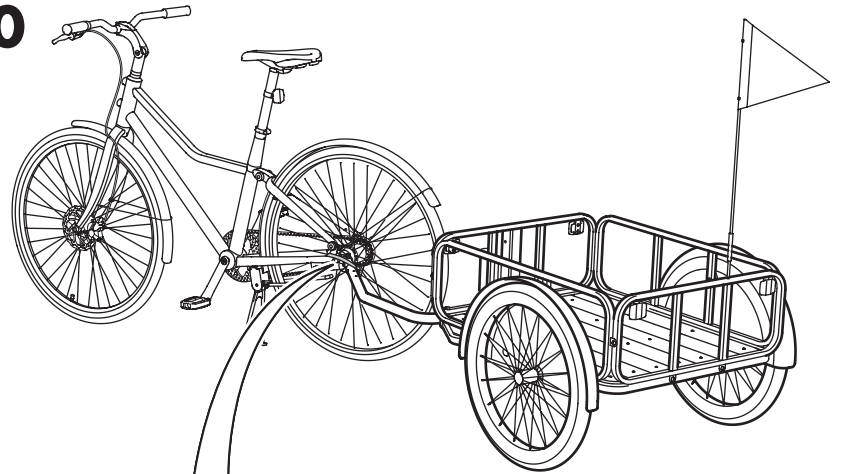

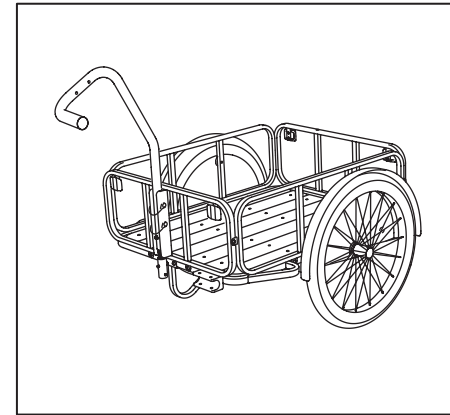
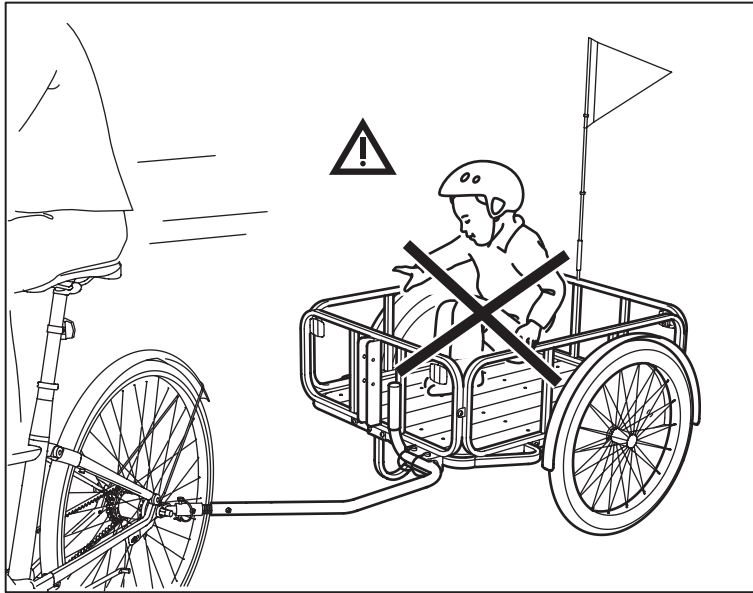

7

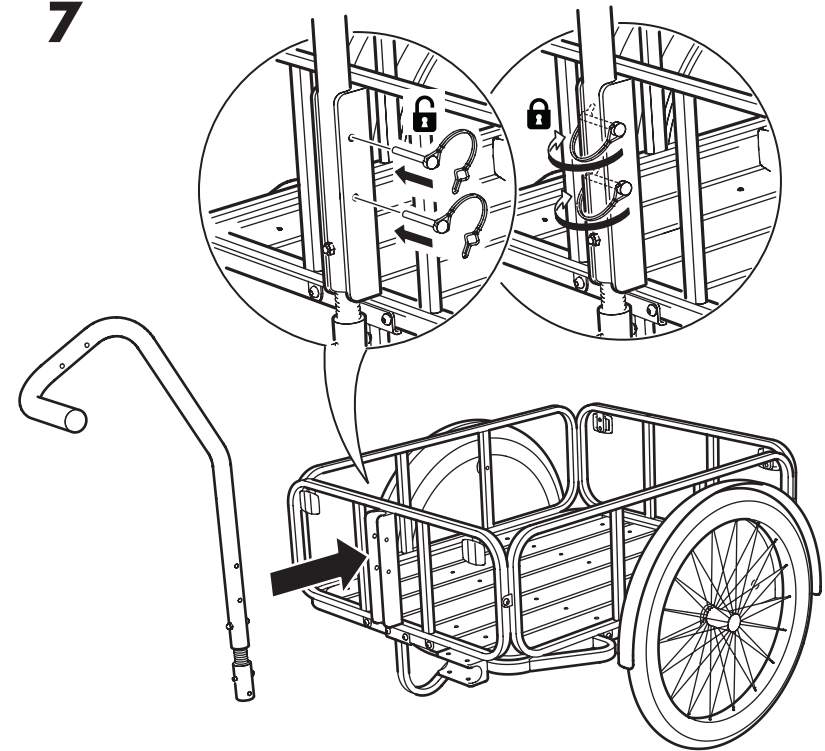

8

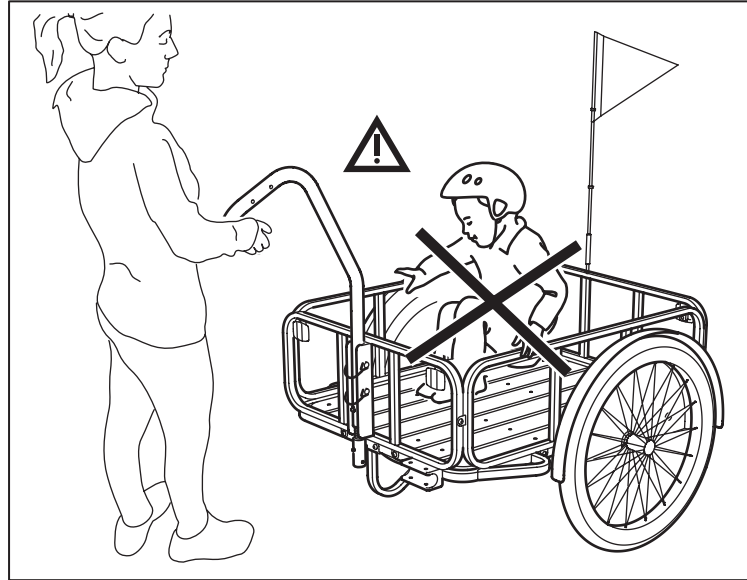
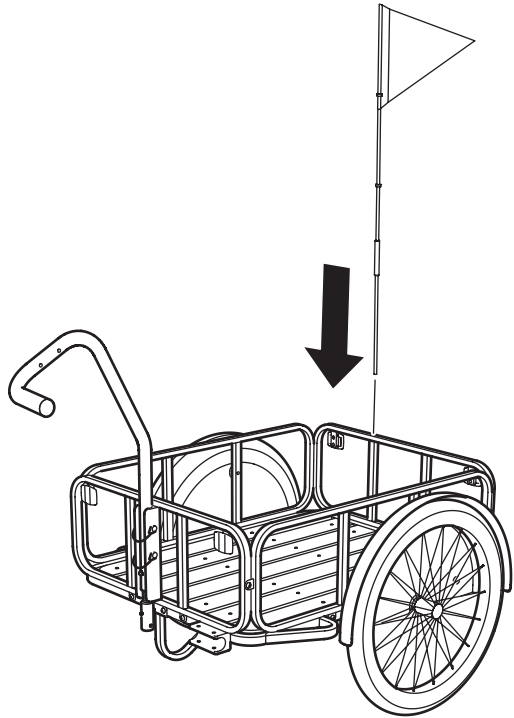

6. TEST YOUR TRAILER

Before using your trailer you should perform a safety check on level ground and away from heavy traffic. It is important that you ensure all parts are fastened and working properly.

TEST THE TYRES

Make sure that the tyres are inflated to the recommended pressure limit using a tyre pump with a gauge. The pressure should not exceed the recommended limit as stated on the tyre. It is better to use a hand or foot pump rather than a service station pump as over inflation can cause the tyre to blow out.

CHECK REFLECTORS

Check that reflectors are positioned correctly.



WARNING: *As with all mechanical components, the trailer is subjected to wear and high stress. Different materials and components may react to wear or stress fatigue in different ways. If the design life of a component has been exceeded, it may suddenly fail possibly causing injuries to the rider. Any form of cracks, scratches or change of colouring in highly stressed areas indicate that the life of the component has been reached and it should be replaced.*

DEUTSCH

INHALT

1. ACHTUNG	13
2. SICHERHEIT	13
3. WARTUNG UND UNTERHALT	13
4. TEILE & KOMPONENTEN	14
5. DEN ANHÄNGER MONTIEREN	15
6. ZUERST TESTEN	21

1. ACHTUNG



- **ACHTUNG!** Der Bremsweg ist länger, wenn man mit dem Anhänger am Rad fährt.
- Passend für SLADDA Fahrrad 26" und 28".
- **HINWEIS!** Wenn der Anhänger mit einem anderen Fahrrad benutzt werden soll, unbedingt im Handbuch des Fahrrads nachschlagen, ob der Anhängeschlag passt und welche Art von Anhänger zugelassen ist. Bitte beachten: den Anhänger keinesfalls an ein Mountainbike, Rennrad, Elektrofahrrad oder ein anderes Fahrrad mit Hilfsmotor ankuppeln.
- Der SLADDA Anhänger ist nicht geeignet für den Transport von Kindern oder Tieren. Für korrekte und sichere Montage und Benutzung des Anhängers die Angaben im Handbuch befolgen.

2. SICHERHEIT

Zur eigenen Sicherheit immer die geltenden Verkehrsregeln beachten.

3. WARTUNG UND UNTERHALT

Regelmäßig die Anhängerteile wie Montageschrauben, Befestigungsbeschläge, Rahmen, Reflektoren und Reifen überprüfen.

IKEA of Sweden AB
34381 Älmhult
Sweden

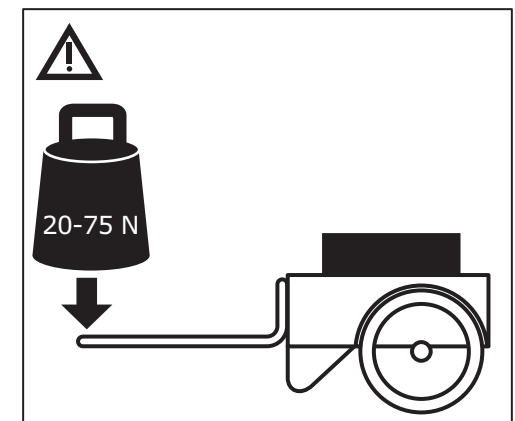
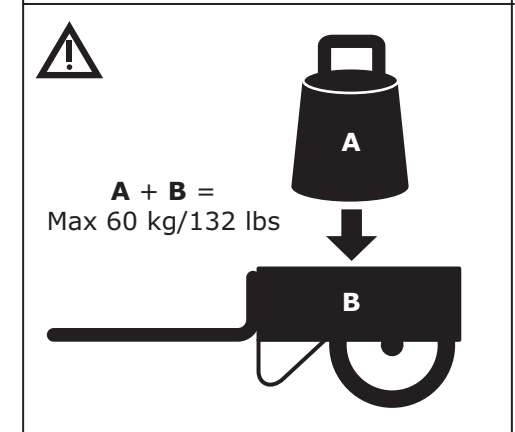
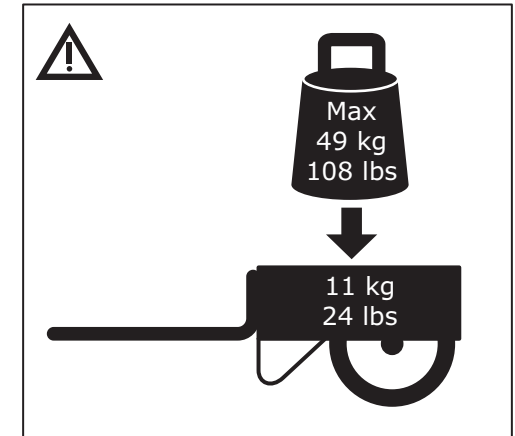

4. TEILE & KOMPONENTEN

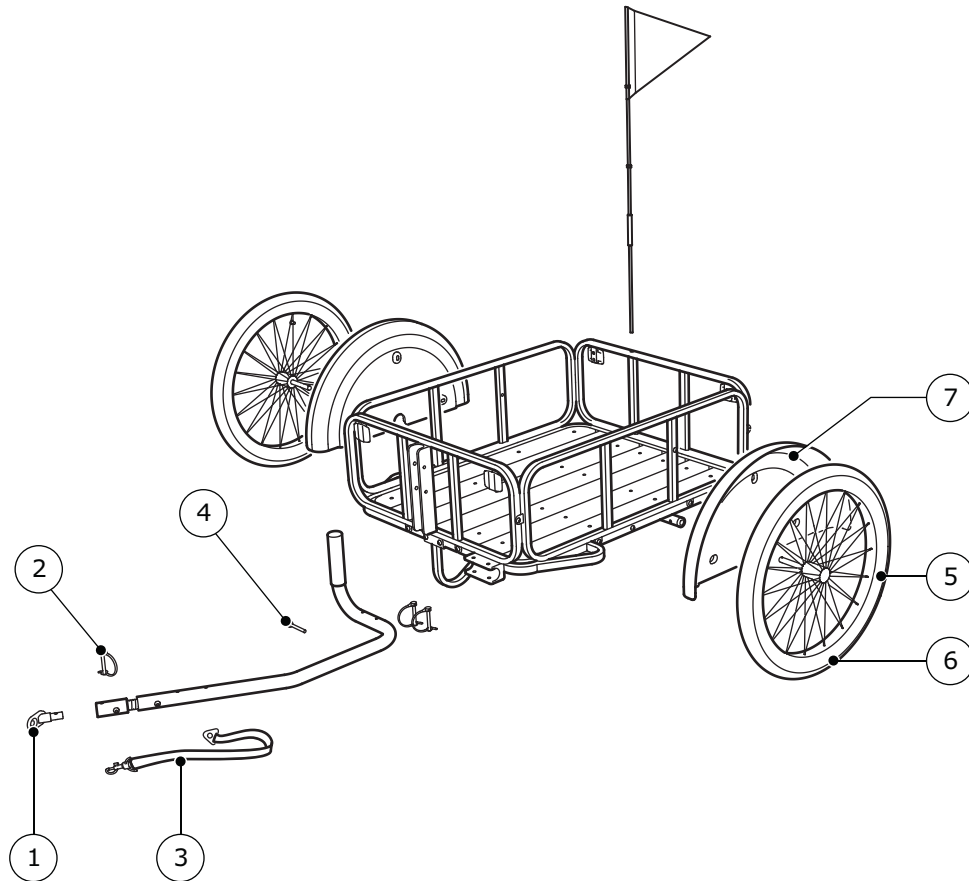

- 1 Kupplung (152921)
- 2 Schloss (152922)
- 3 Sicherungsgurt (152923)
- 4 M5-Schraube (152924)
- 5 Rad (Reifen & Schlauch) (152925)
- 6 Reifen (152926)
- 7 Schmutzfänger (152927)

5. DEN ANHÄNGER MONTIEREN

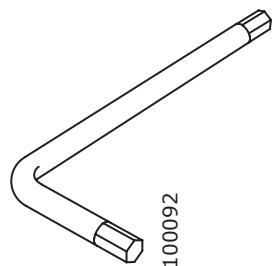
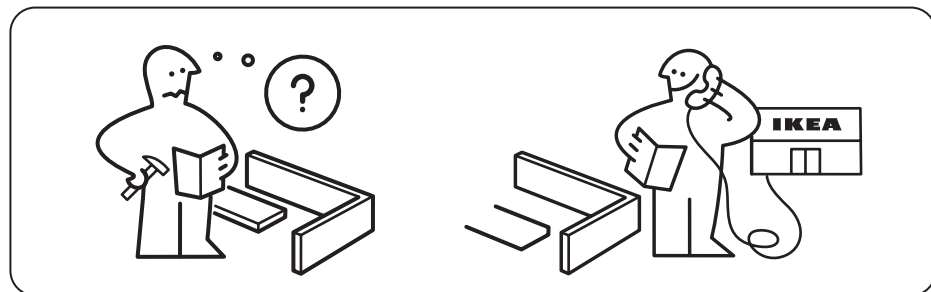
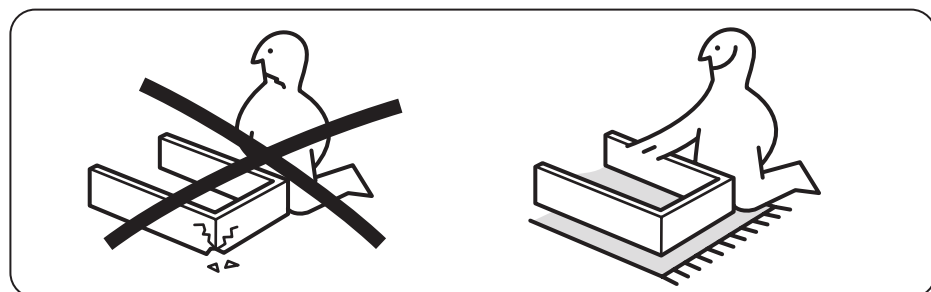
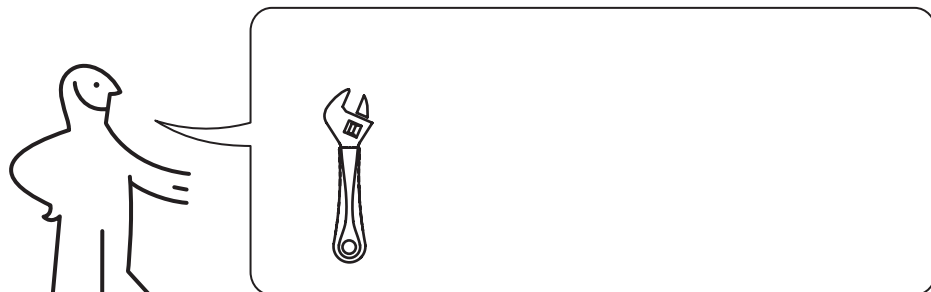

1x

100092

1

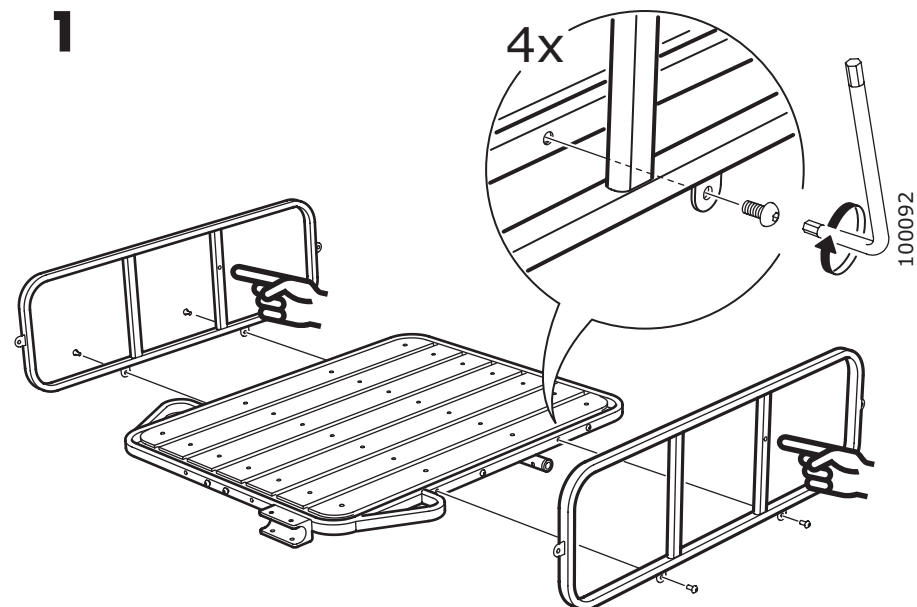

2

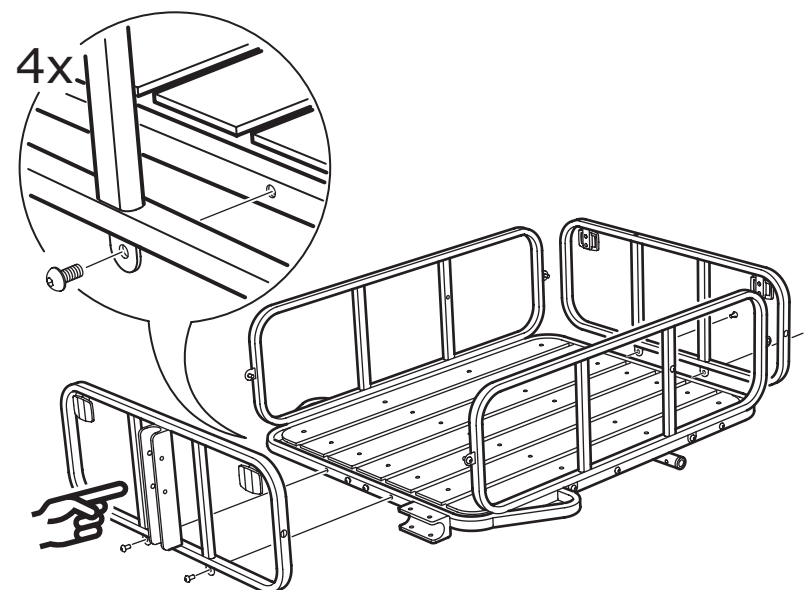

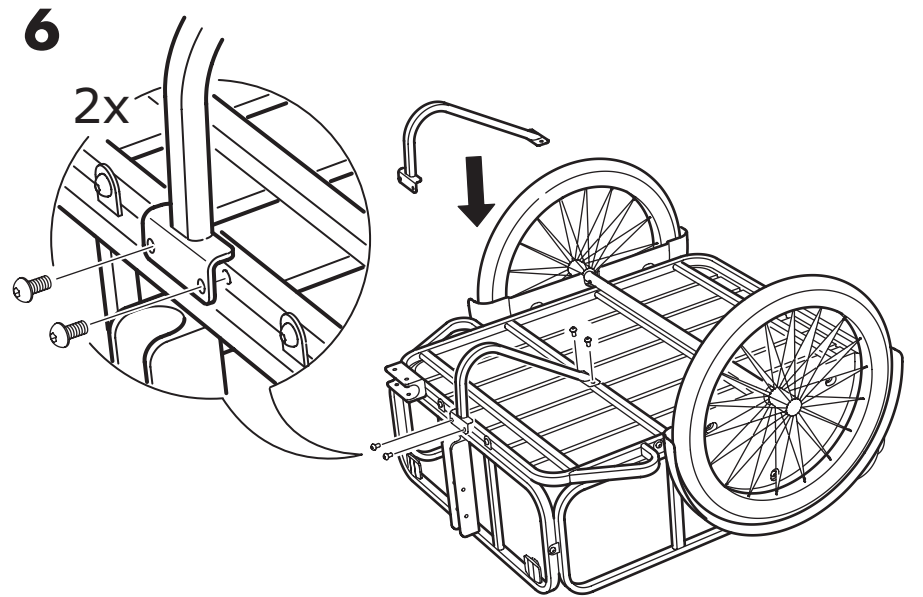
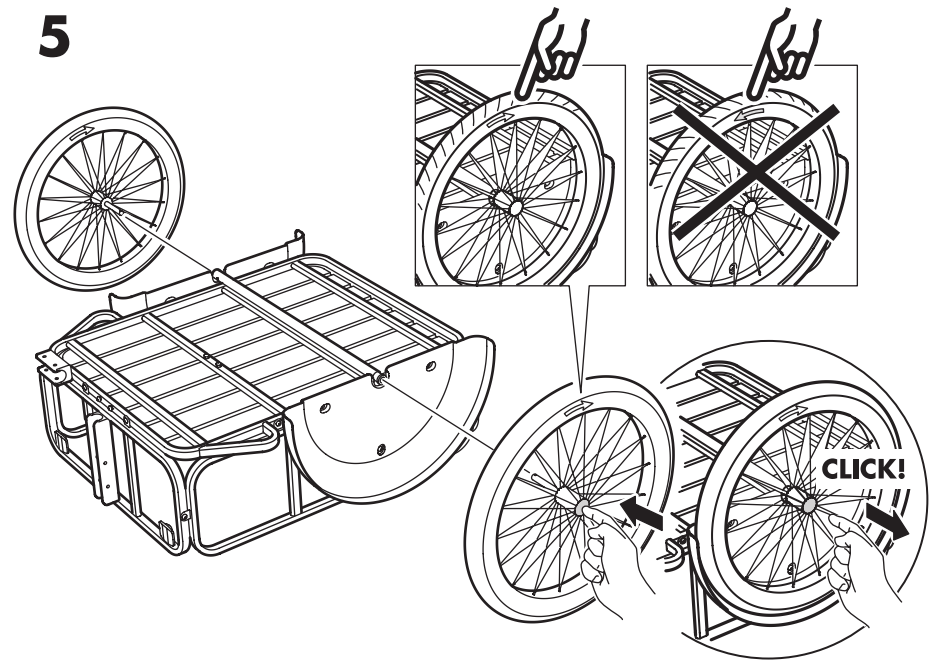
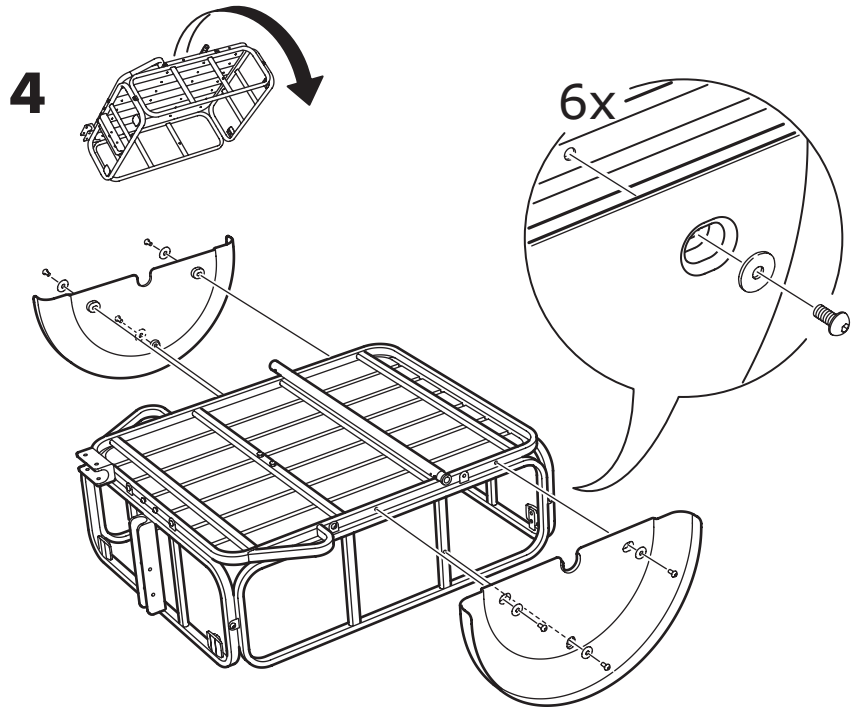
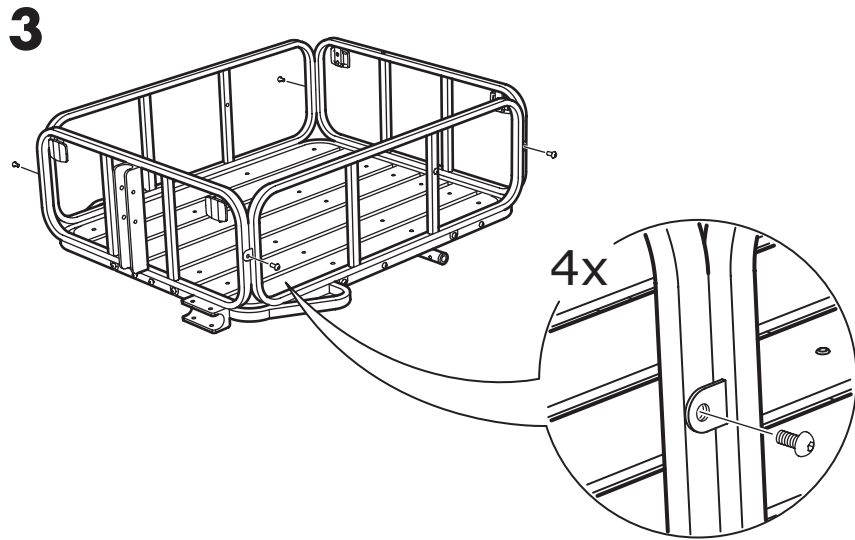

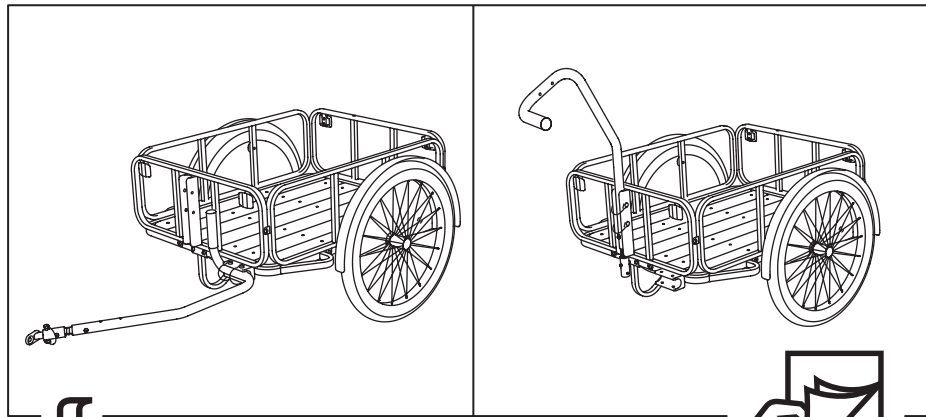

7

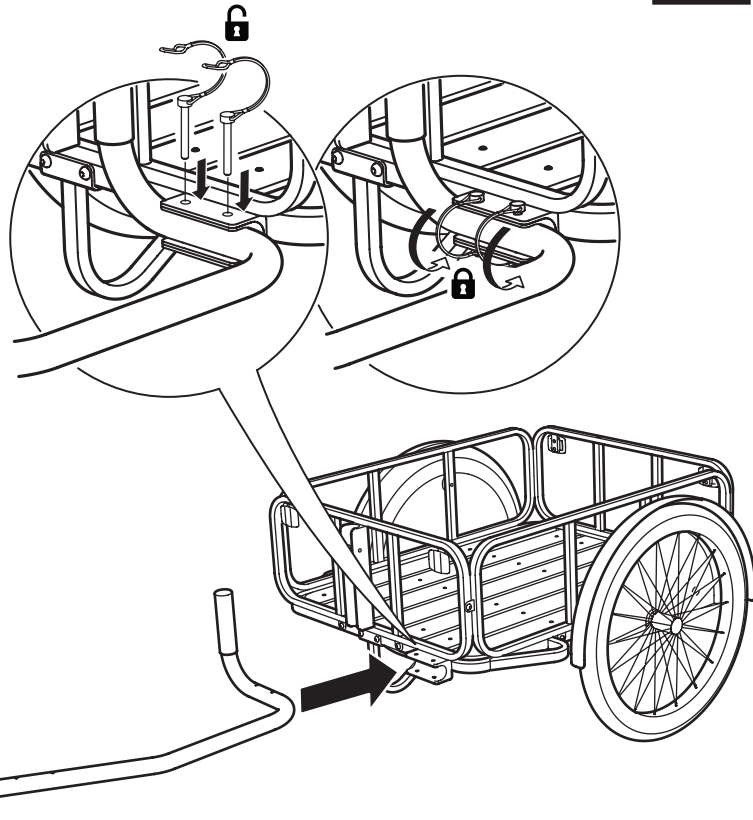

8

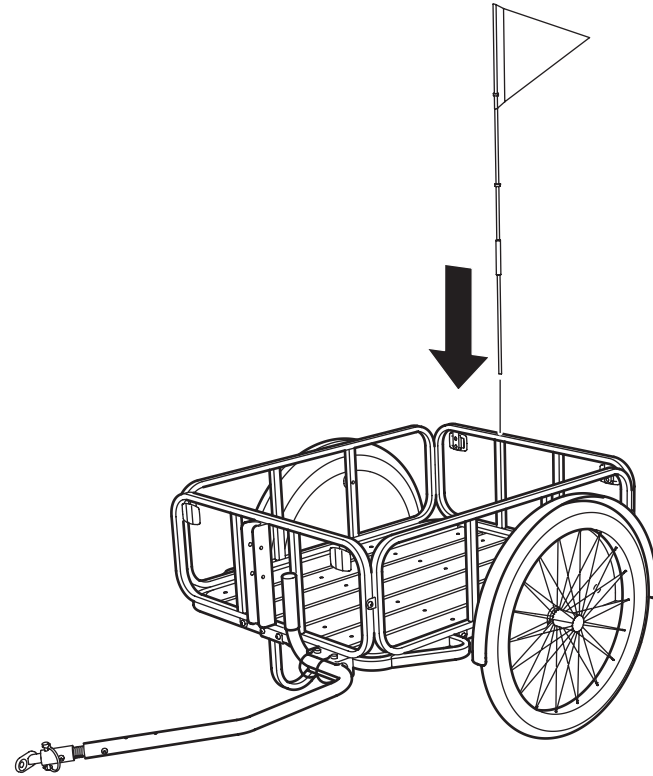

9

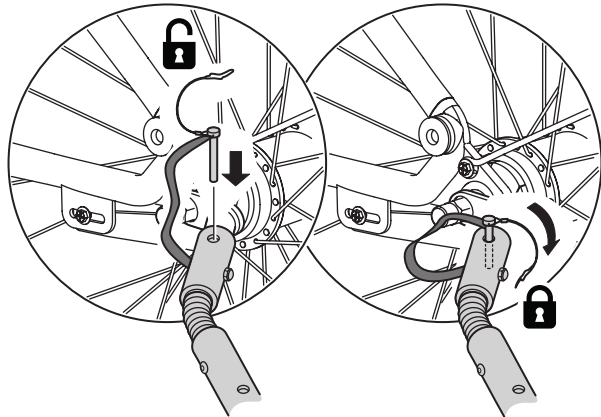
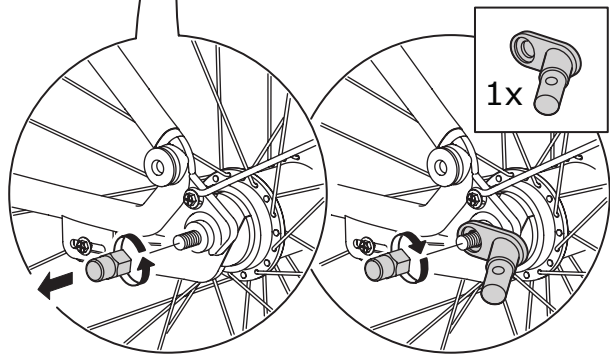
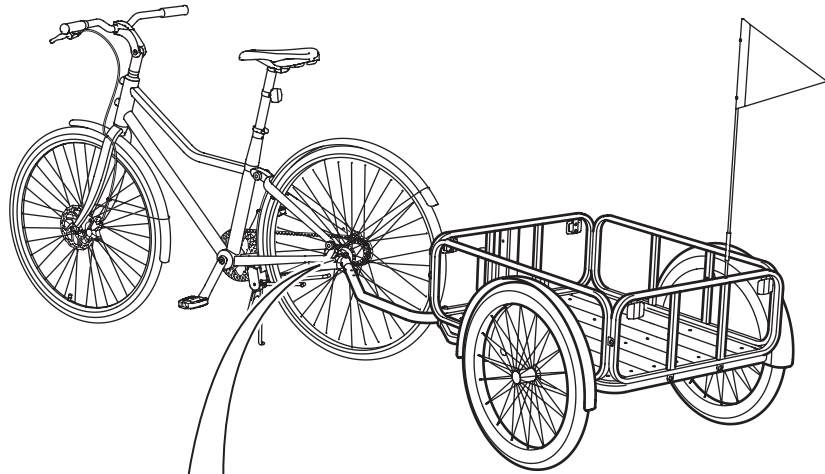

10

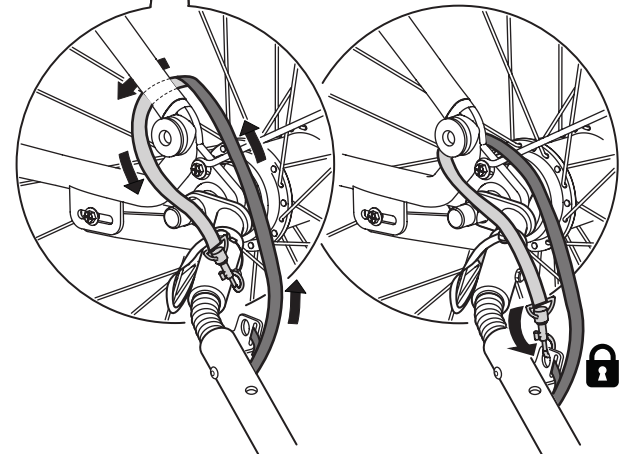
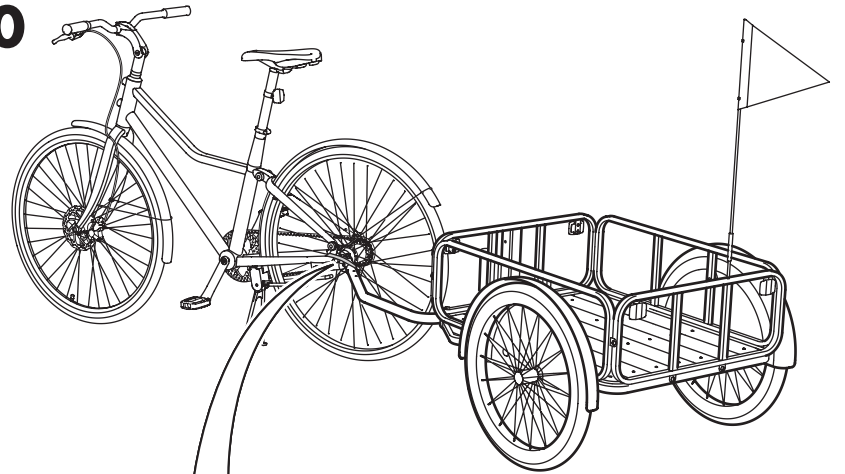

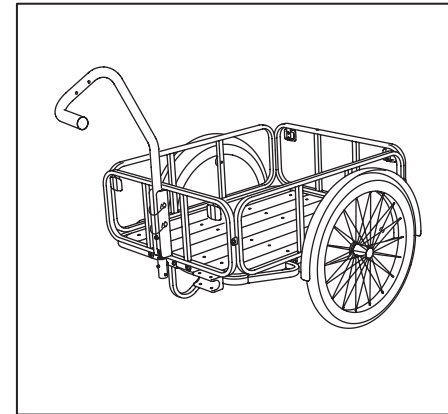
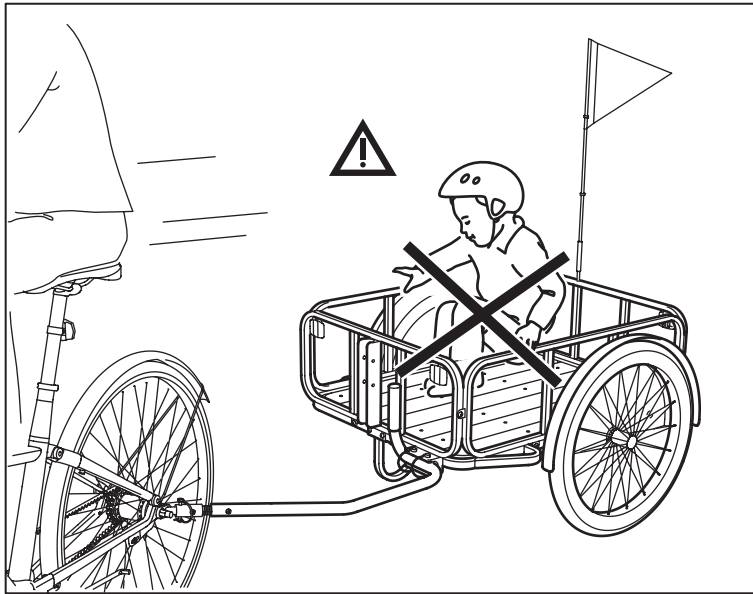

7

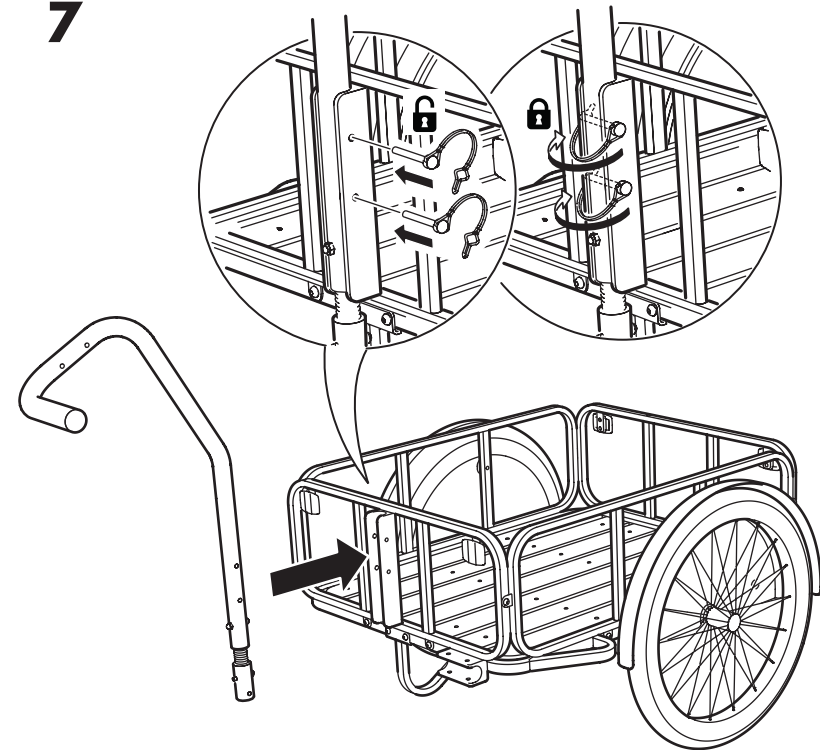

8

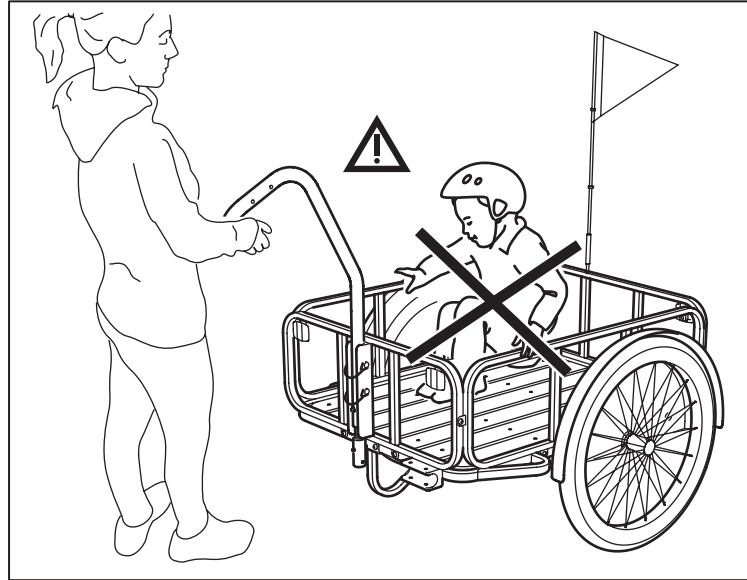
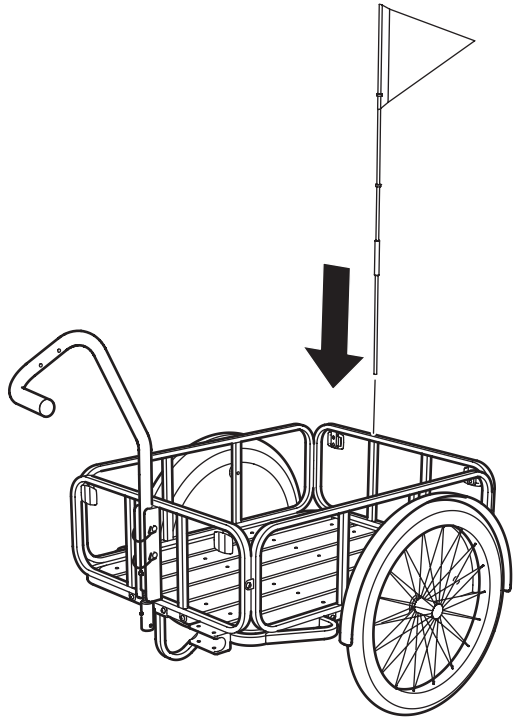

6. ZUERST TESTEN

Vor der Benutzung des Anhängers empfiehlt sich ein Sicherheitstest an einem Platz in ebener Lage mit wenig Verkehr. Es ist wichtig, dass alle Teile gut und sicher befestigt sind und ordnungsgemäß funktionieren.

REIFEN TESTEN

Kontrollieren, ob die Reifen ausreichend aufgepumpt sind. Das geht am besten mit einer Luftpumpe mit Manometer. Der Druck soll die auf dem Reifen angegebene Grenze nicht überschreiten. Es ist besser, statt einer automatischen Pumpe eine Hand- oder Fußluftpumpe zu benutzen, da bei Überdruck der Reifen platzen könnte.

REFLEKTOREN PRÜFEN

Kontrollieren, dass alle Reflektoren an der richtigen Stelle sitzen.



ACHTUNG! Wie alle anderen Produkte mit mechanischen Komponenten und Bauteilen ist auch ein Anhänger Verschleiß und Materialermüdung ausgesetzt. Material und Teile reagieren unterschiedlich auf hohe Beanspruchung. Wenn die ausgelegte Lebensdauer eines Bauteils überschritten ist, kann es plötzlich aufhören, zu funktionieren und der Benutzer des Produkts kann dadurch zu Schaden kommen. Risse, Sprünge oder Farbveränderungen in stark beanspruchten Bereichen können Warnzeichen sein, dass die Verschleißgrenze des Teils erreicht ist und es ausgetauscht werden muss.

TABLE DES MATIÈRES

1. ATTENTION	22
2. SÉCURITÉ	22
3. NETTOYAGE ET ENTRETIEN	22
4. COMPOSANTS ET CARACTÉRISTIQUES	23
5. MONTAGE DE LA REMORQUE	24
6. VÉRIFIER LA REMORQUE AVANT UTILISATION	30

1. ATTENTION



- **Attention !** La distance de freinage augmente quand le vélo tracte une remorque.
- Convient aux vélos SLADDA 26" et 28".
- **REMARQUE !** Si vous voulez utiliser cette remorque avec un autre vélo, lisez le manuel de cet autre vélo pour vous assurer qu'il comporte les fixations nécessaires et qu'il peut tracter une remorque. Remarque importante ! Ne jamais accrocher la remorque à un VTT, un vélo de course, un vélo à assistance électrique ou un vélo avec moteur.
- La remorque SLADDA ne convient pas au transport des enfants ou des animaux. Suivre les instructions du manuel pour monter et utiliser correctement la remorque en toute sécurité.

2. SECURITE

Pour votre sécurité, toujours suivre les règles du code de la route en vigueur dans votre pays.

3. NETTOYAGE ET ENTRETIEN

Vérifiez régulièrement les éléments constitutifs de la remorque, vis de montage, fixations, structure, bandes réfléchissantes et pneus.

IKEA of Sweden AB
34381 Älmhult
Sweden

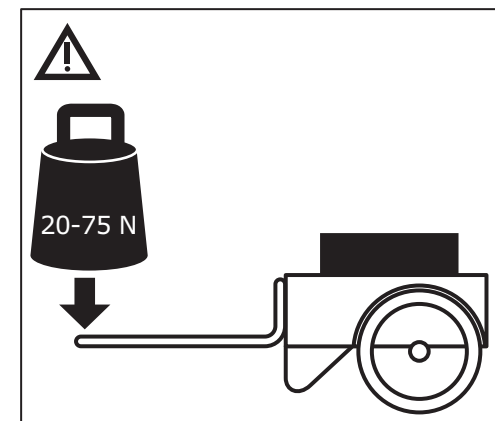
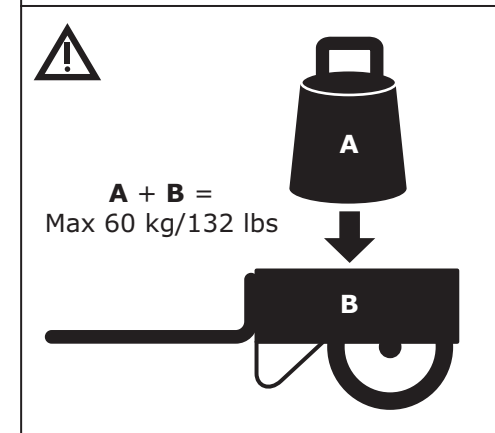
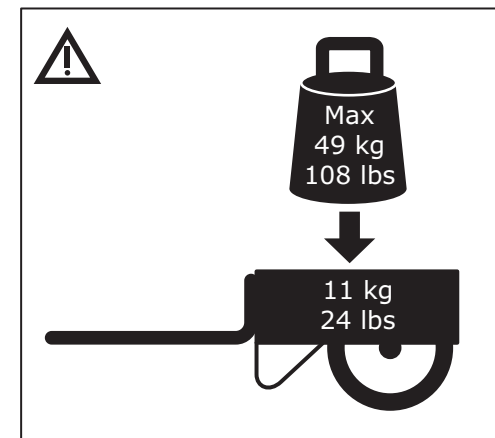

4. COMPOSANTS ET CARACTÉRISTIQUES:

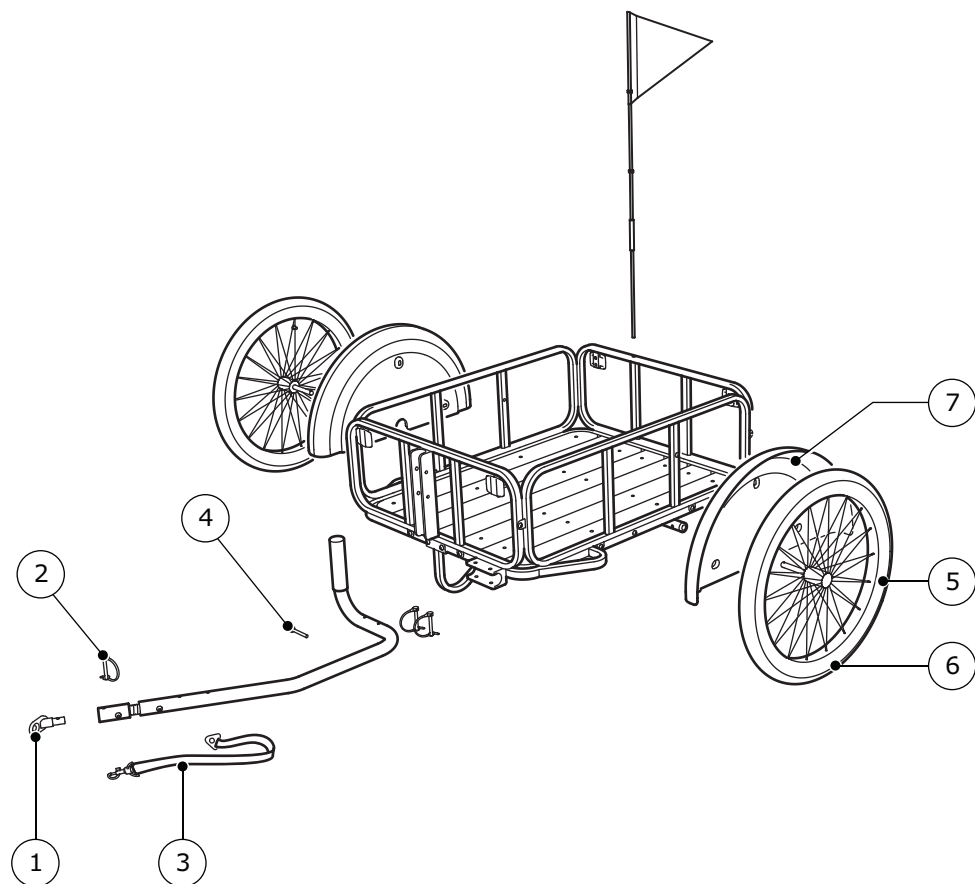

- 1 Pièce de raccordement (152921)
- 2 Mousqueton (152922)
- 3 Courroie de sécurité (152923)
- 4 Vis M5 (152924)
- 5 Pneu, chambre à air (152925)
- 6 Pneu (152926)
- 7 Garde-boue (152927)

5. MONTAGE DE LA REMORQUE

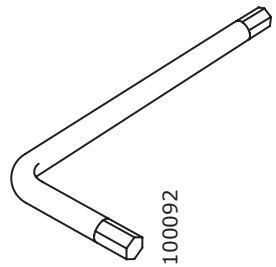
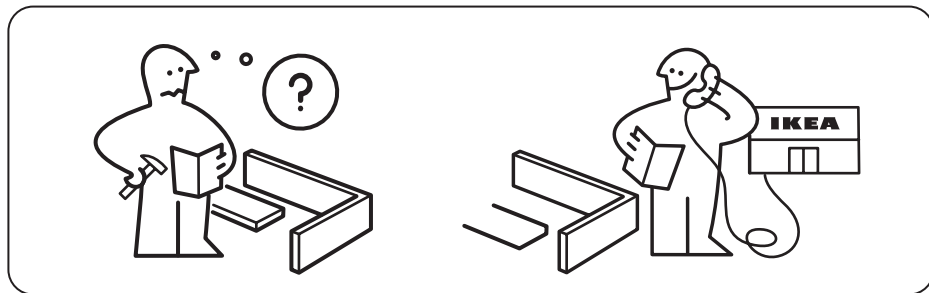
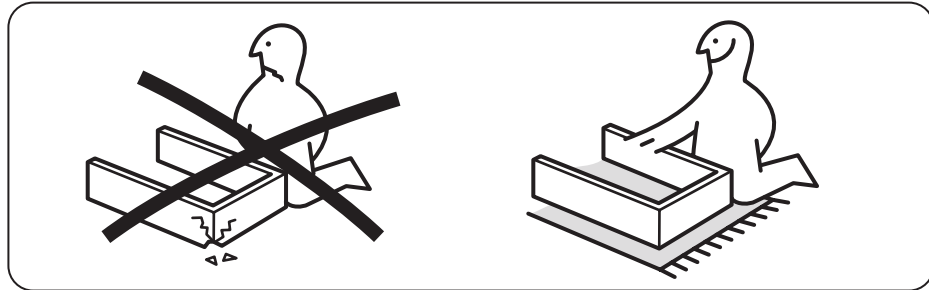
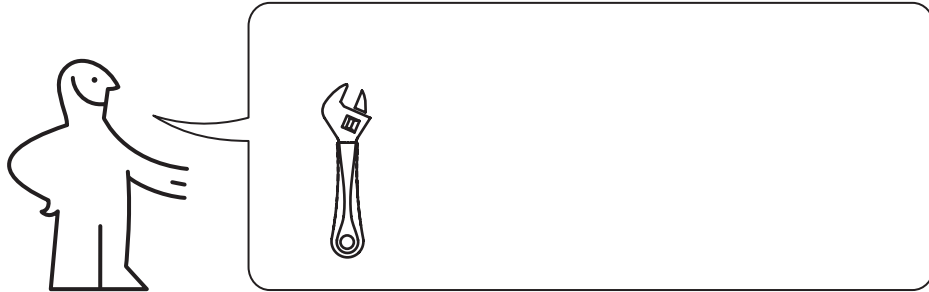

100092

1x

1

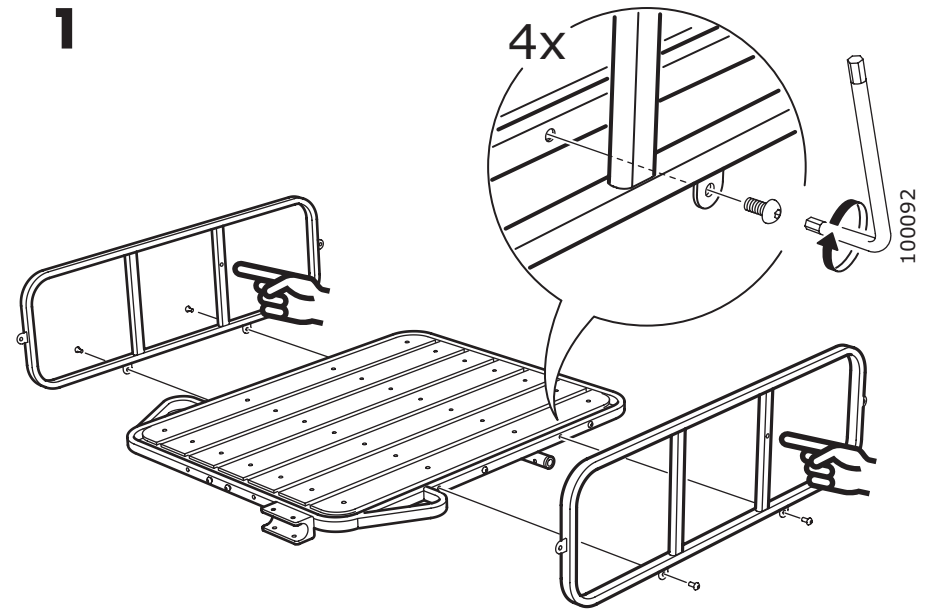

2

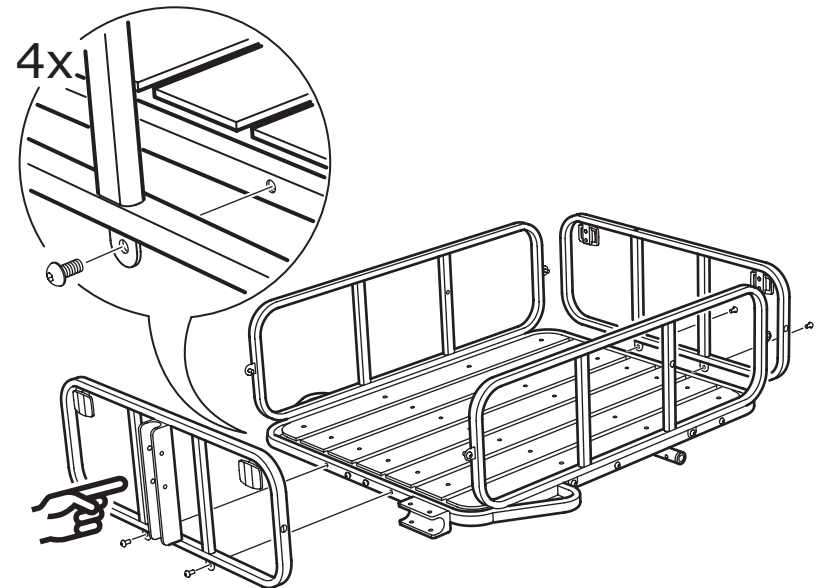

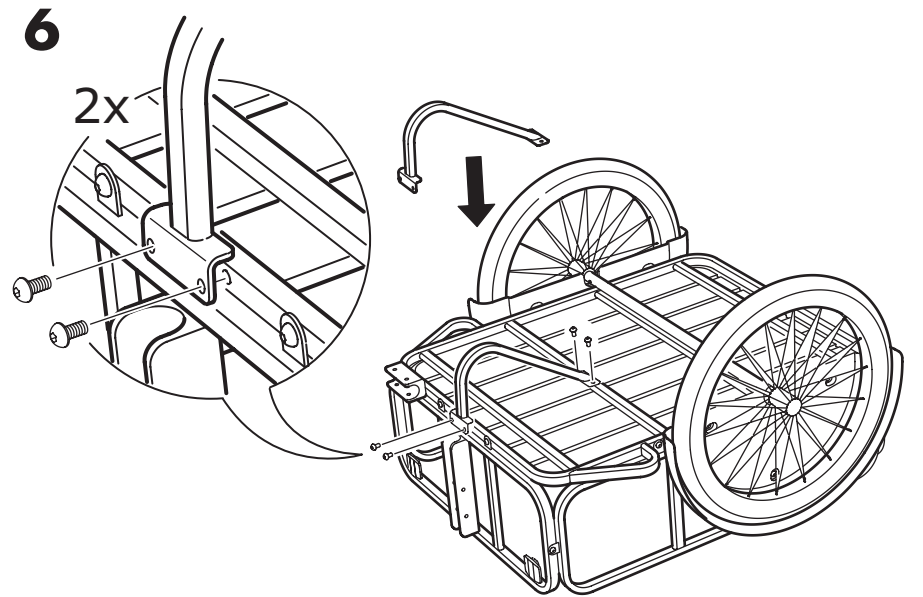
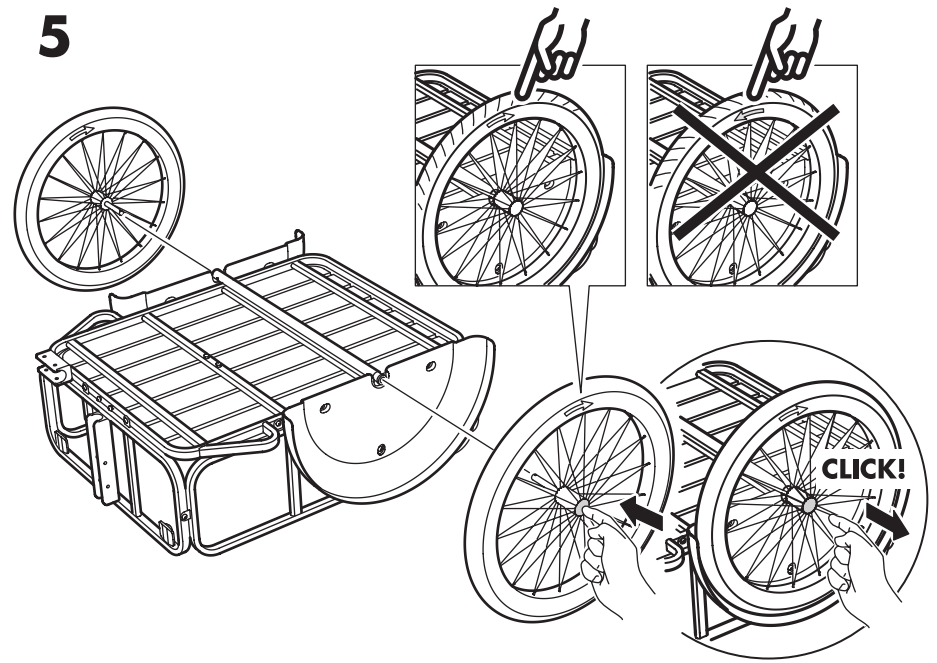
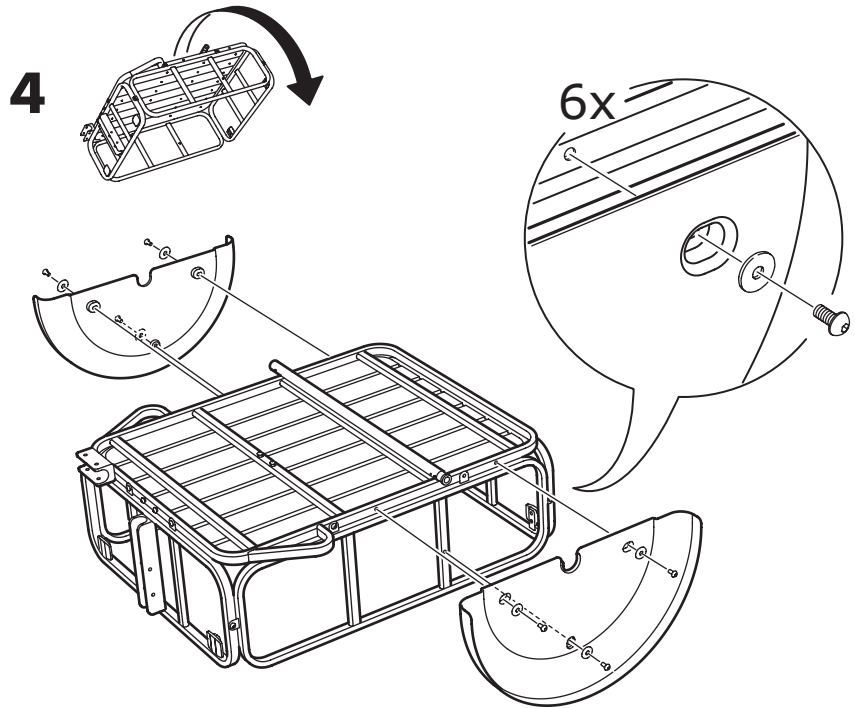
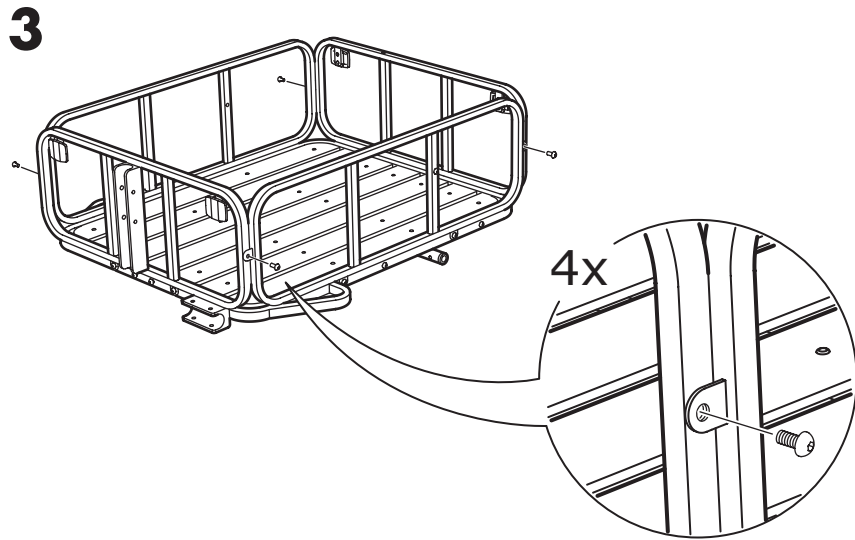

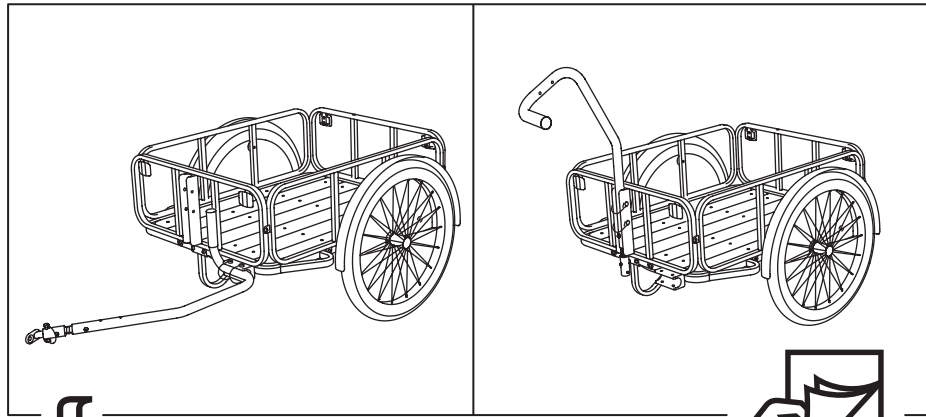

7

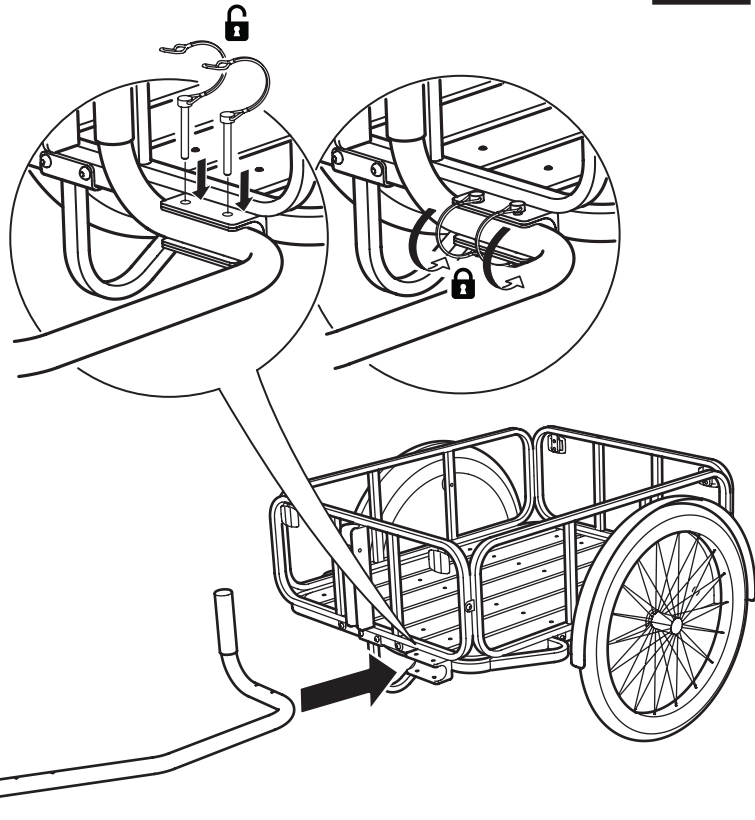

8

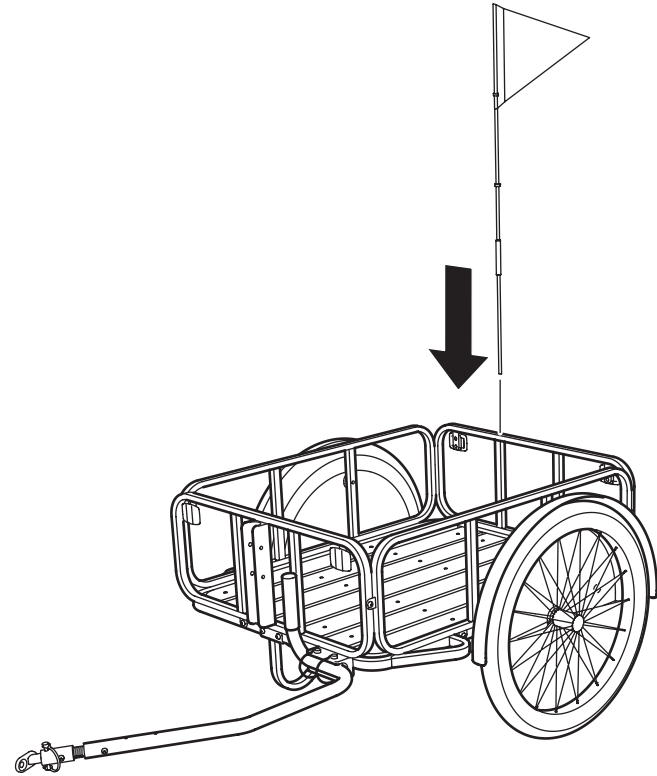

9

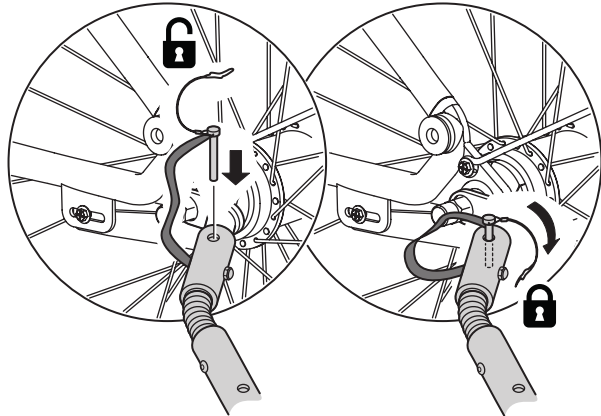
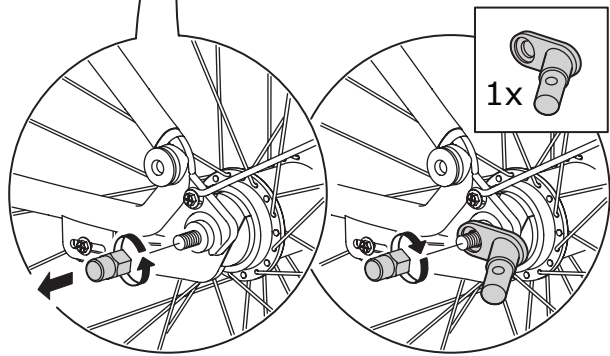
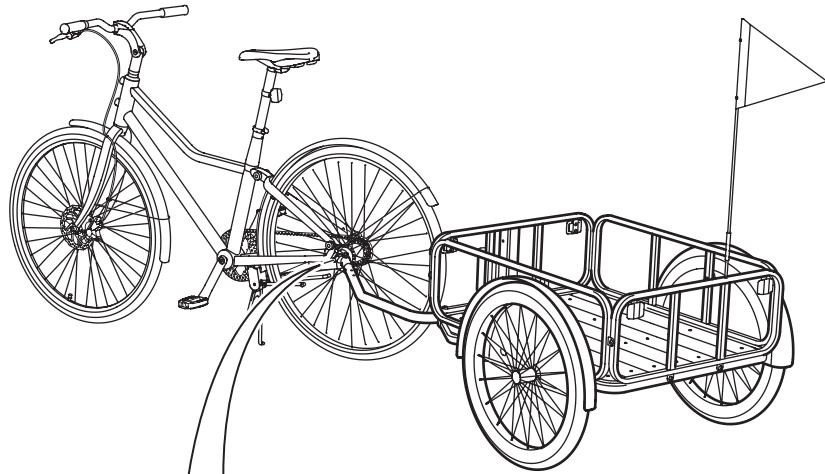

10

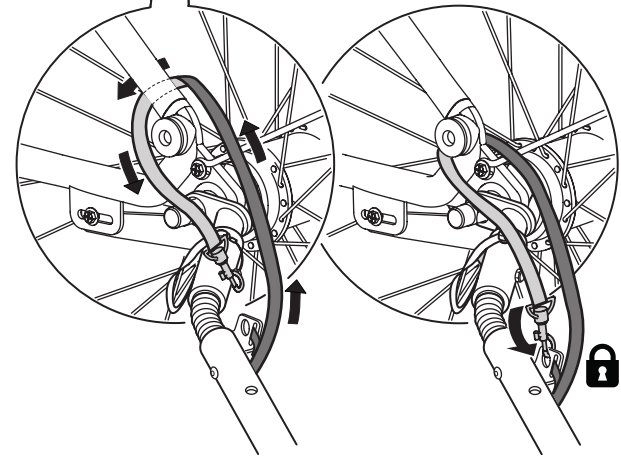
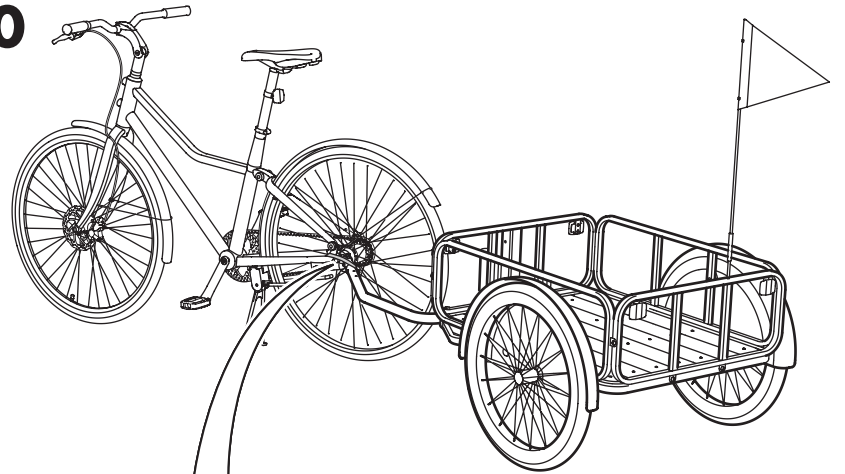

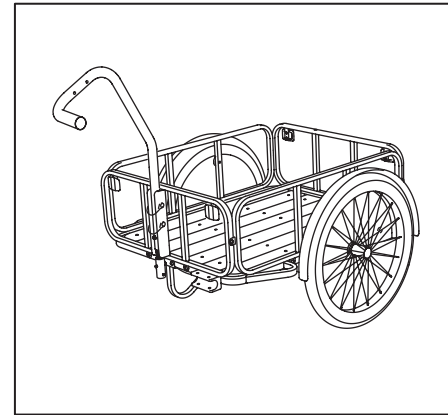
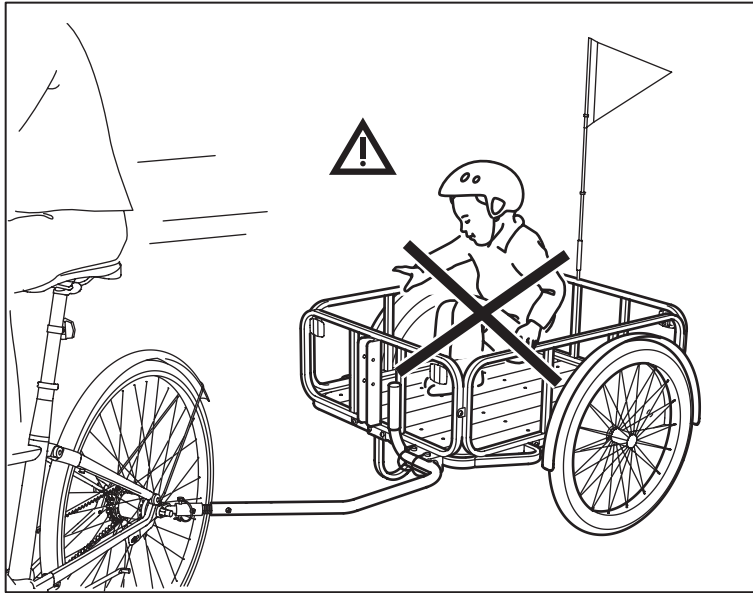

7

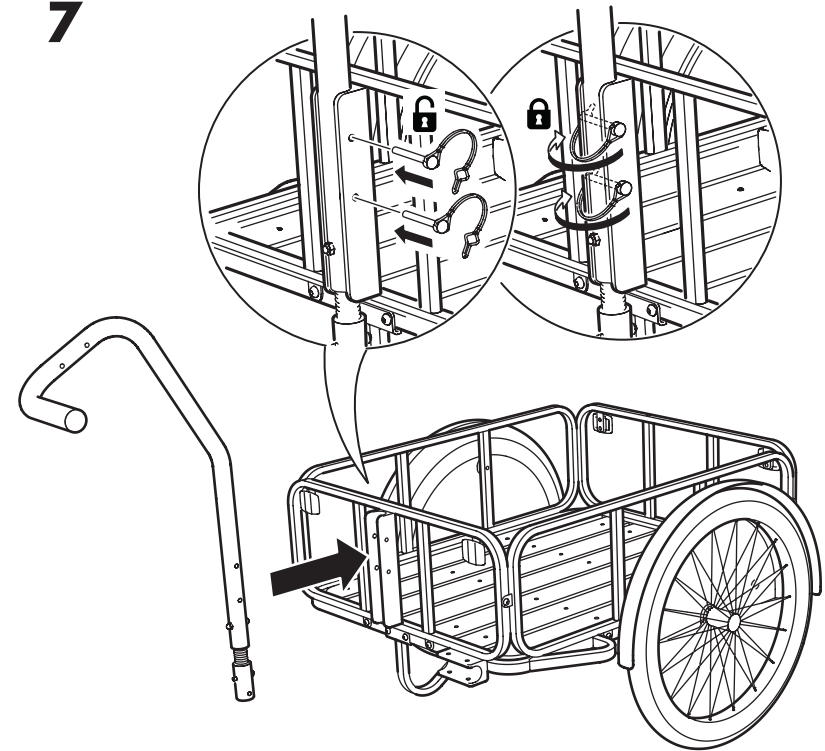

8

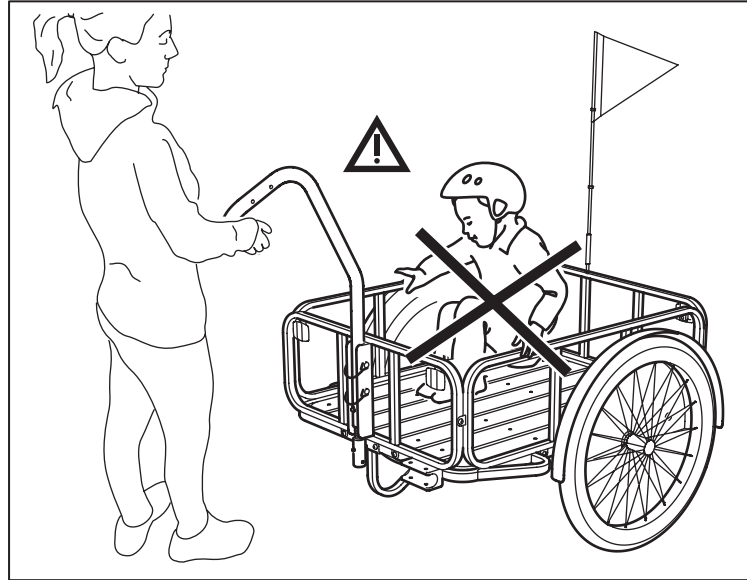
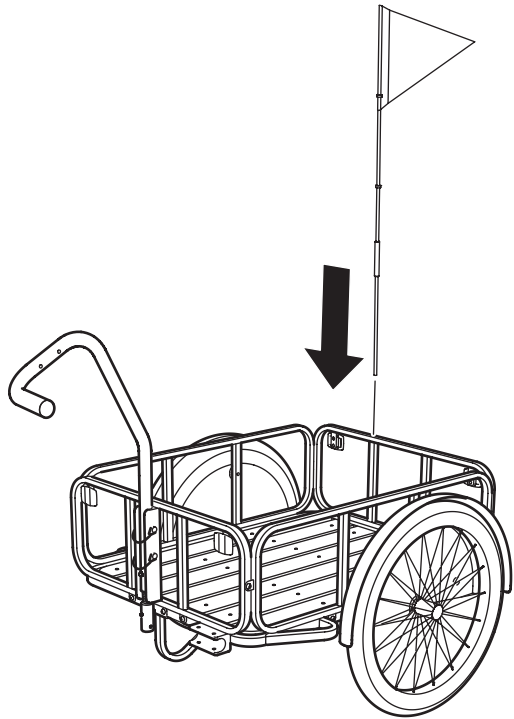

6. VÉRIFIER LA REMORQUE AVANT UTILISATION

Avant d'utiliser votre remorque, faites un test sur un terrain plat, à l'écart de la circulation. Il est important de s'assurer que toutes les pièces sont bien fixées et en état de marche.

VERIFIEZ LES PNEUS

Assurez-vous que les pneus sont gonflés conformément à la pression recommandée. Utilisez pour cela une pompe à vélo équipée d'un manomètre. La pression ne doit pas dépasser la limite recommandée indiquée sur le pneu. Il est préférable d'utiliser une pompe à main ou à pied plutôt qu'un compresseur de station-service, en raison du risque de surgonflage qui pourrait faire exploser le pneu.

VERIFIEZ LES ELEMENTS REFLECHISSANTS

Vérifiez que les éléments réfléchissants sont correctement positionnés.



ATTENTION : Comme c'est le cas pour toutes les pièces mécaniques, les pièces de votre remorque sont soumises à l'usure et à de fortes contraintes. Les matériaux et les pièces sont différents et réagissent différemment à l'usure et aux contraintes répétées. Quand la fin de la durée de vie d'une pièce est dépassée, elle peut subitement lâcher ou ne plus fonctionner et être la cause de blessures pour le cycliste. Toute fissure, rayure ou changement de couleur d'éléments très sollicités indique que la pièce a atteint la fin de sa durée de vie et qu'il faut la remplacer.

NEDERLANDS

INHOUD

1. WAARSCHUWING	31
2. VEILIGHEID	31
3. VERZORGING EN ONDERHOUD	31
4. ONDERDELEN & COMPONENTEN	32
5. DE FIETSAANHANGER MONTEREN	33
6. DE FIETSAANHANGER TESTEN VOOR GEBRUIK	39

1. WAARSCHUWING



- **Waarschuwing!** Je remweg wordt langer als je met een aanhanger fietst.
- Voor de SLADDA fiets van 26" en 28".
- **MERK OP!** Als je de aanhanger met een andere fiets wilt gebruiken, kijk dan in de handleiding van de fiets of de bevestiging past en wat voor soort aanhanger toegestaan is. Let op: bevestig de aanhanger nooit aan een mountainbike, racefiets, e-bike of andere fiets met hulpmotor.
- De SLADDA aanhanger is niet geschikt voor het vervoeren van kinderen of dieren. Volg de handleiding om de aanhanger op de juiste en veilige manier te monteren en te gebruiken.

2. VEILIGHEID

Voor je eigen veiligheid: volg altijd de verkeersregels die in jouw land gelden.

3. ONDERHOUD

Controleer regelmatig de onderdelen van de aanhanger, zoals montageschroeven, bevestigingen, frame, reflectoren en banden.

IKEA of Sweden AB
34381 Älmhult
Sweden

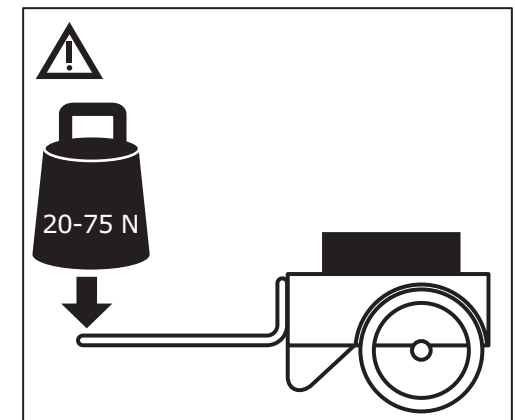
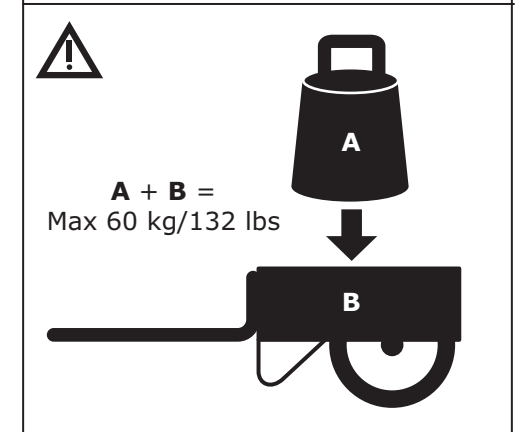
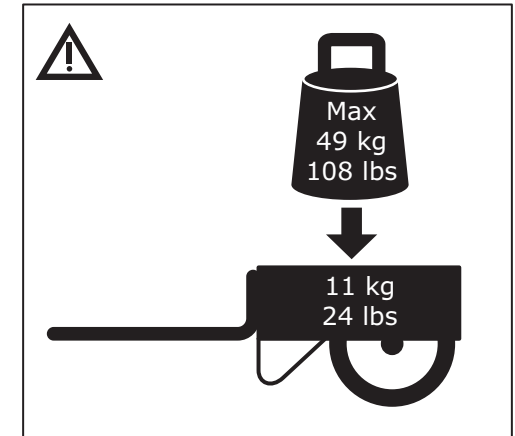

4. ONDERDELEN & COMPONENTEN

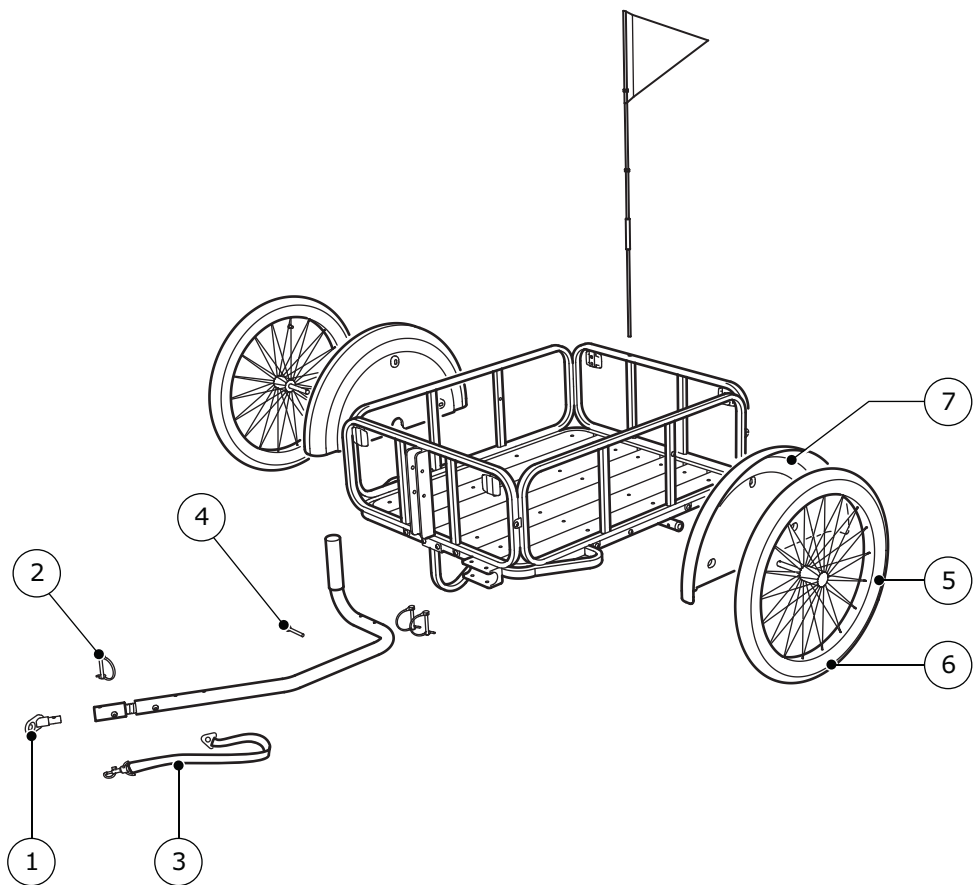

- 1 Koppeling (152921)
- 2 D-vormig slot (152922)
- 3 Veiligheidsriem (152923)
- 4 Schroef (152924)
- 5 Wiel, Band & binnenband (152925)
- 6 Band (152926)
- 7 Spatscher (152927)

5. DE FIETSAANHANGER MONTEREN

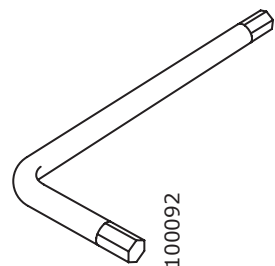
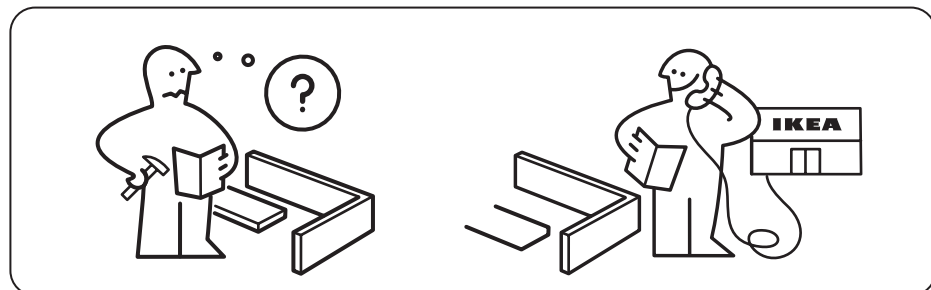
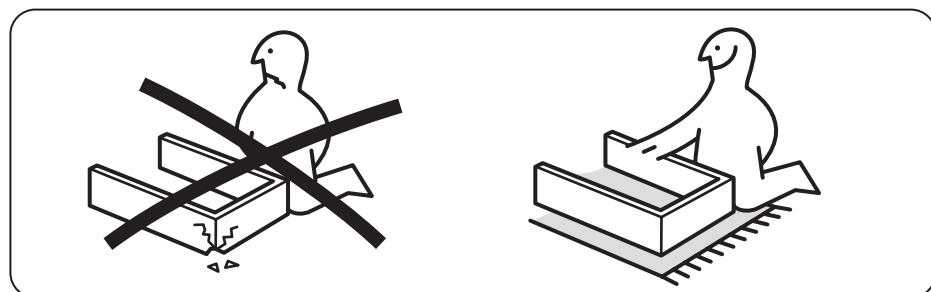
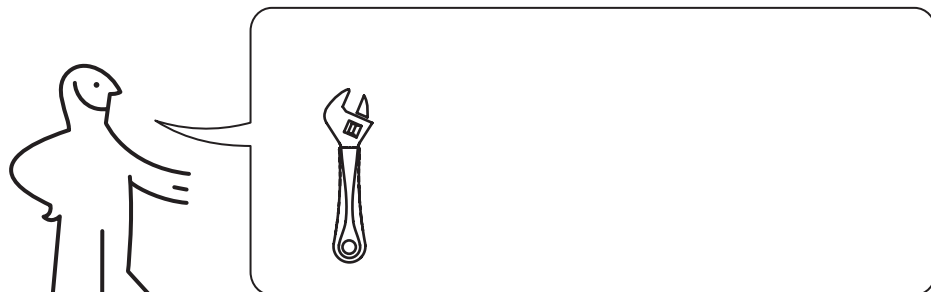

1x

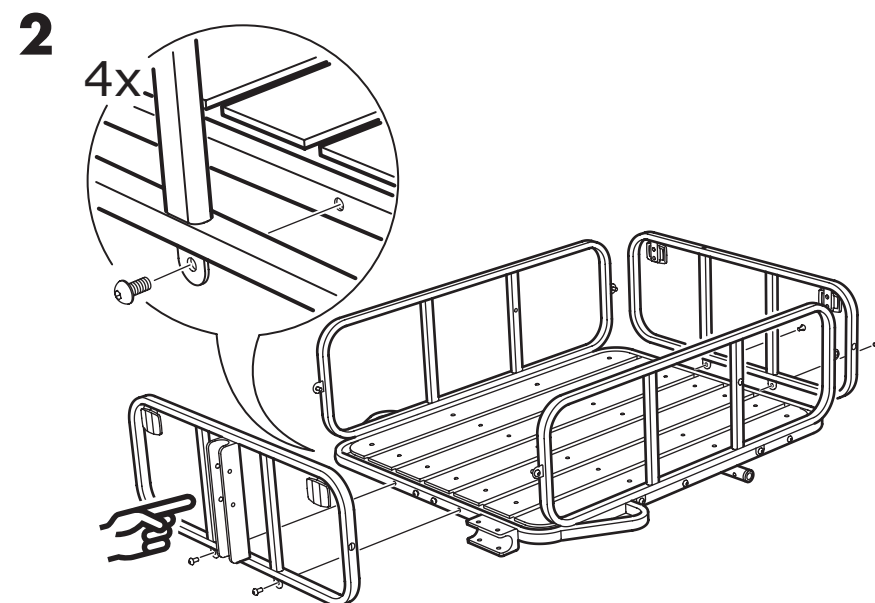
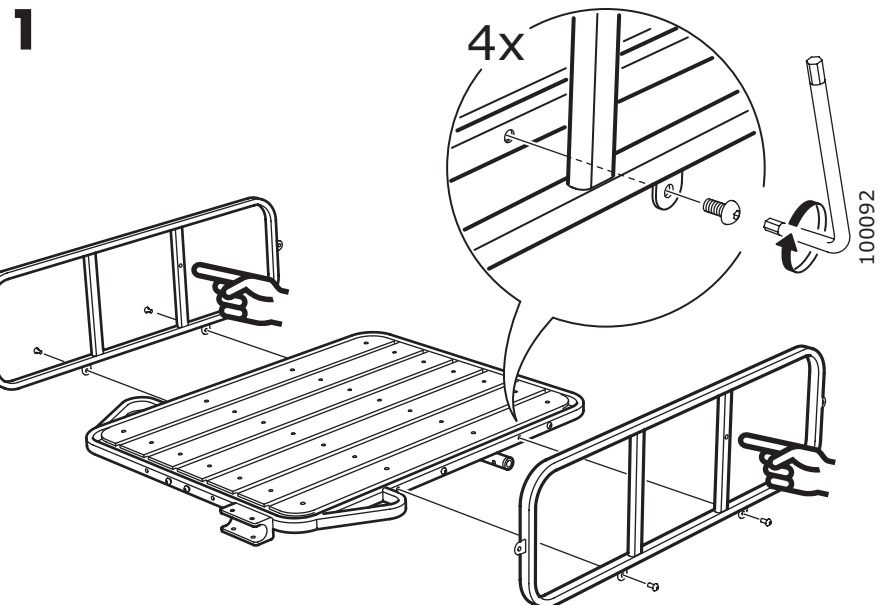

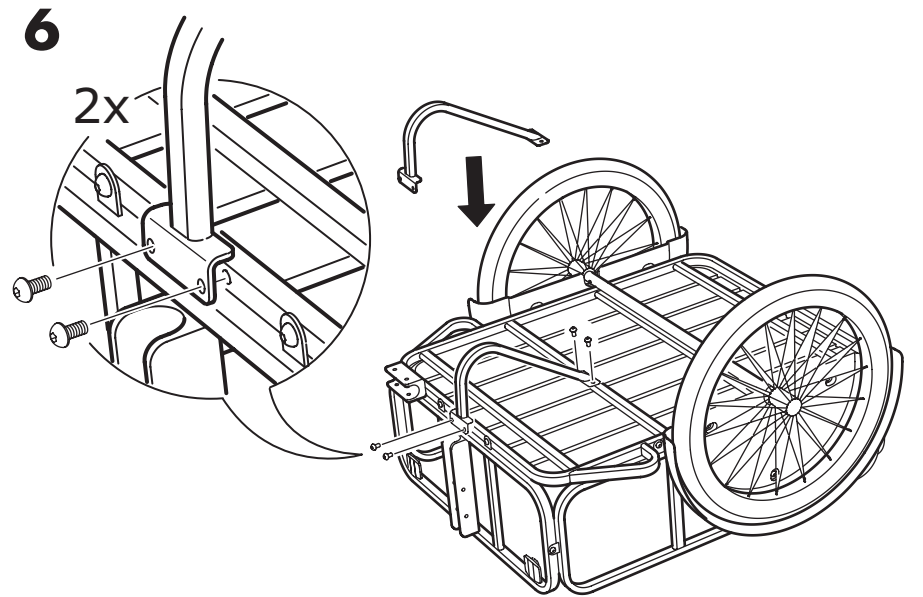
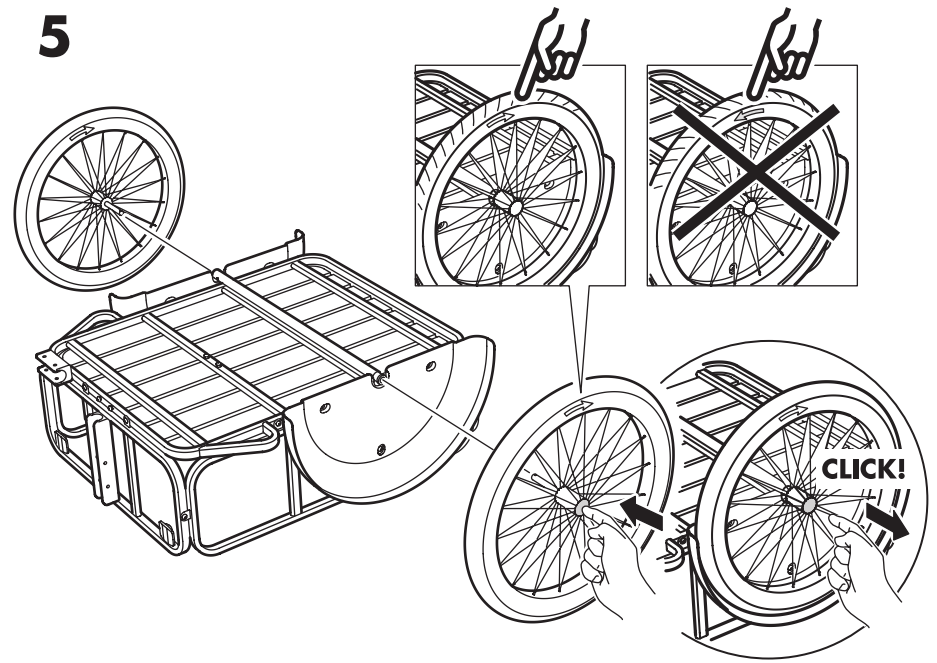
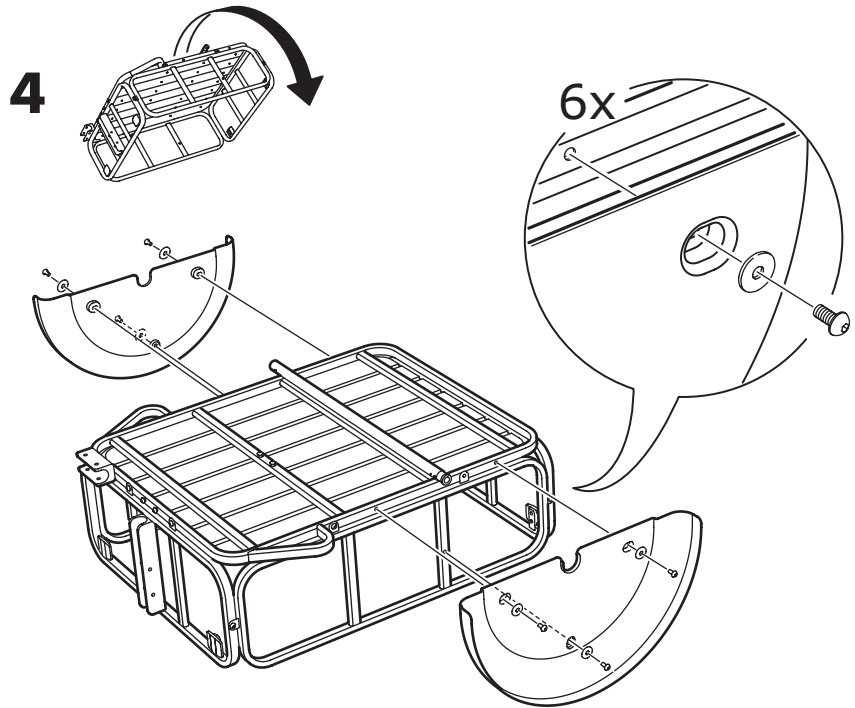
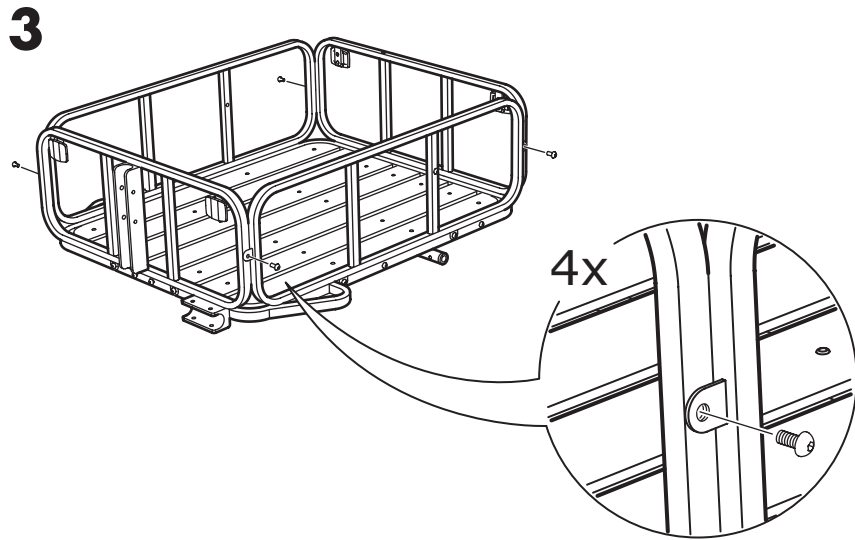

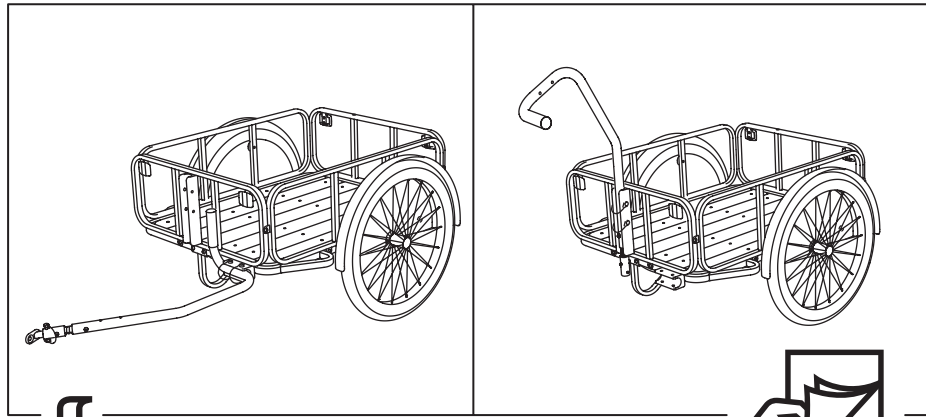

7

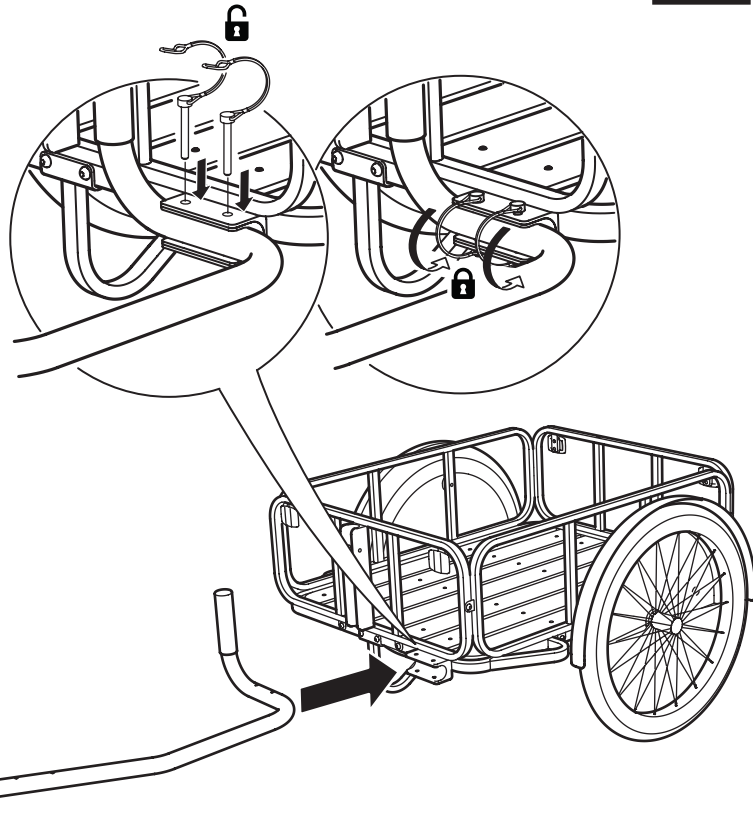

8

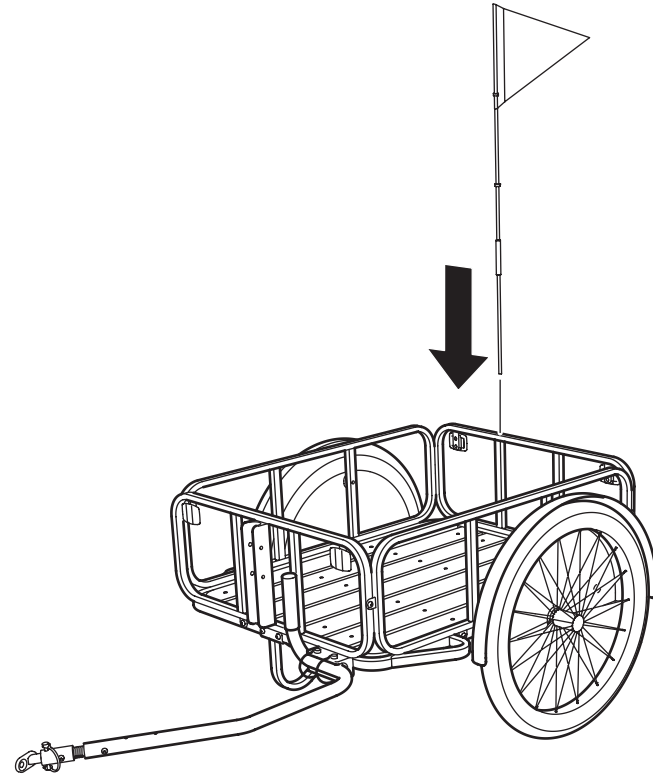

9

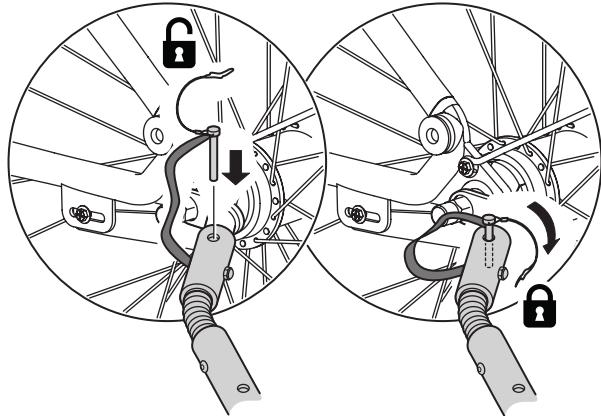
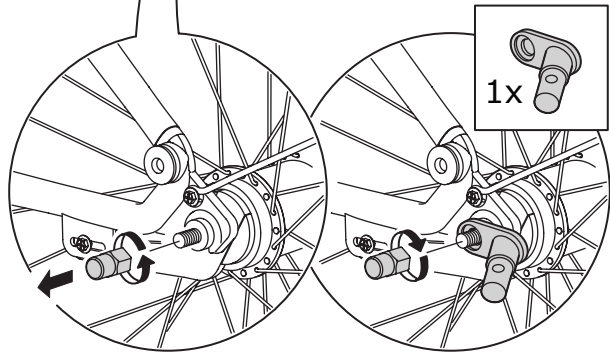
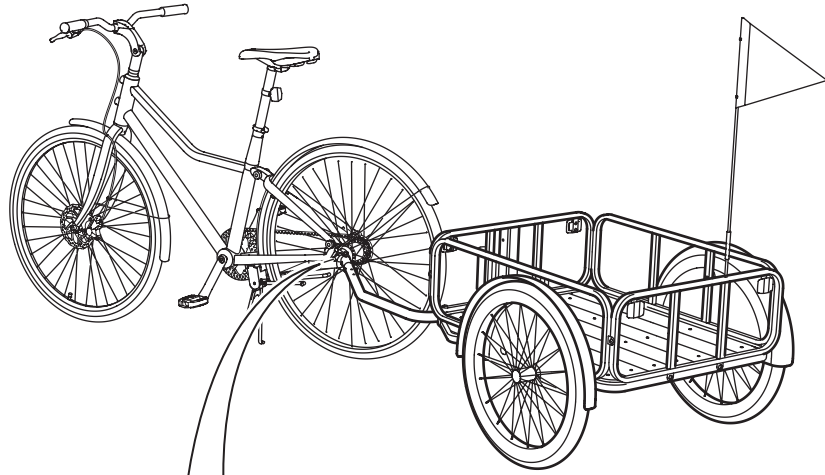

10

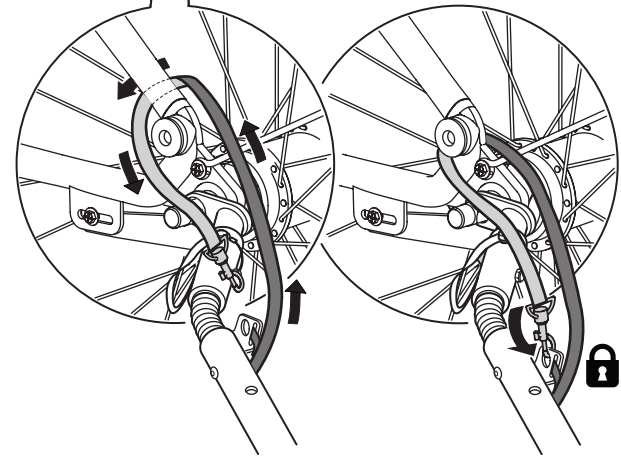
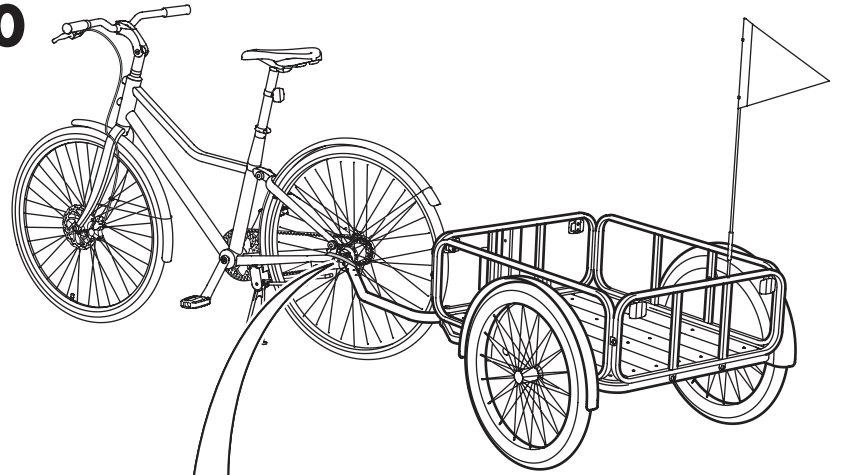

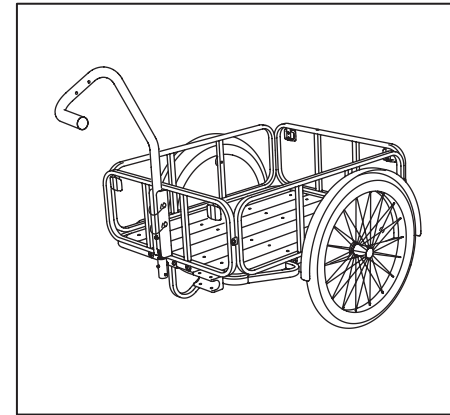
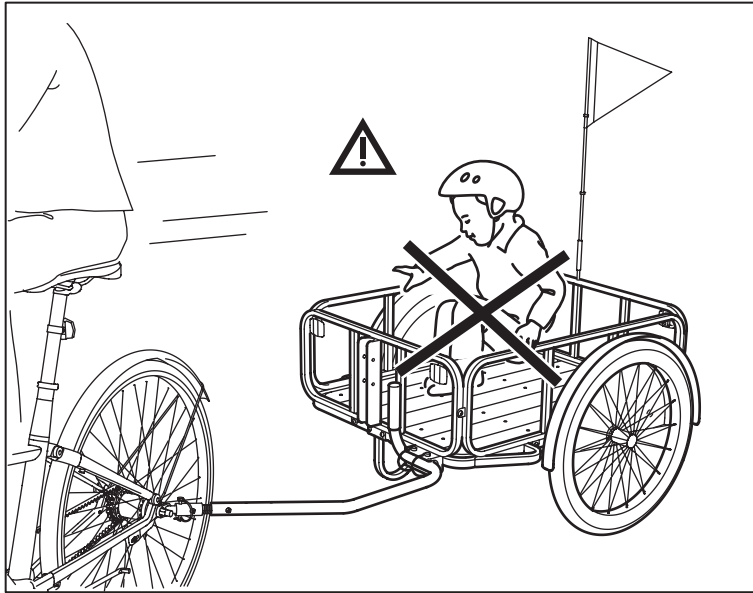

7

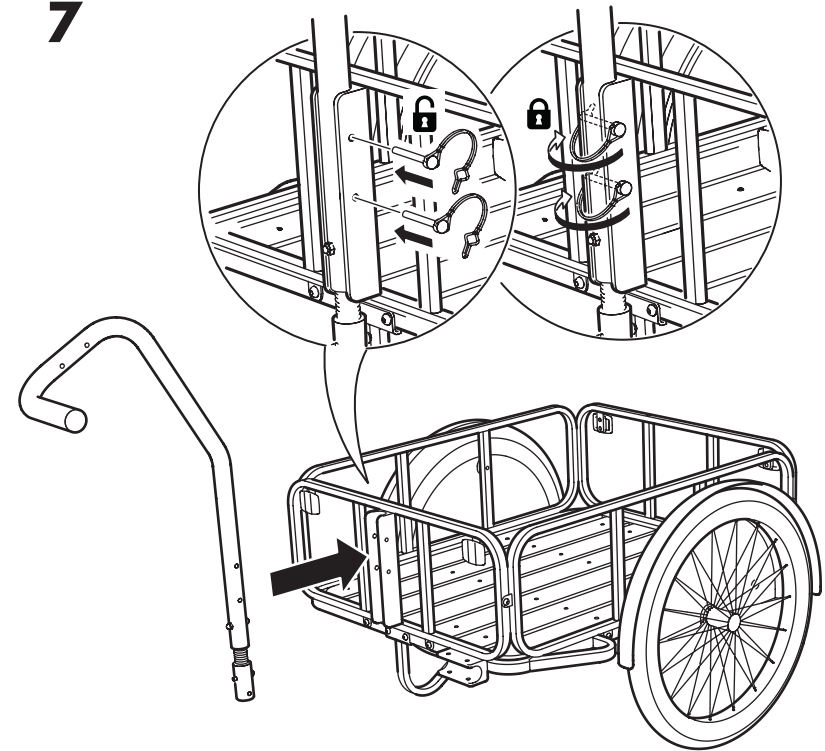

8

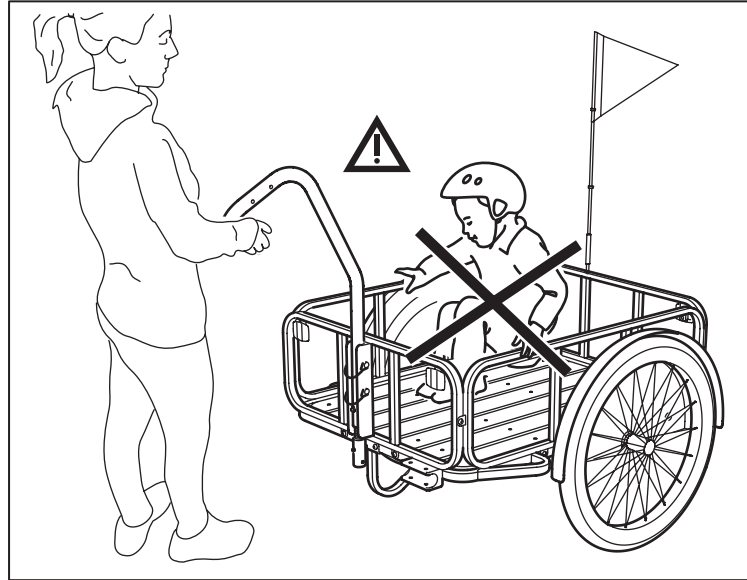
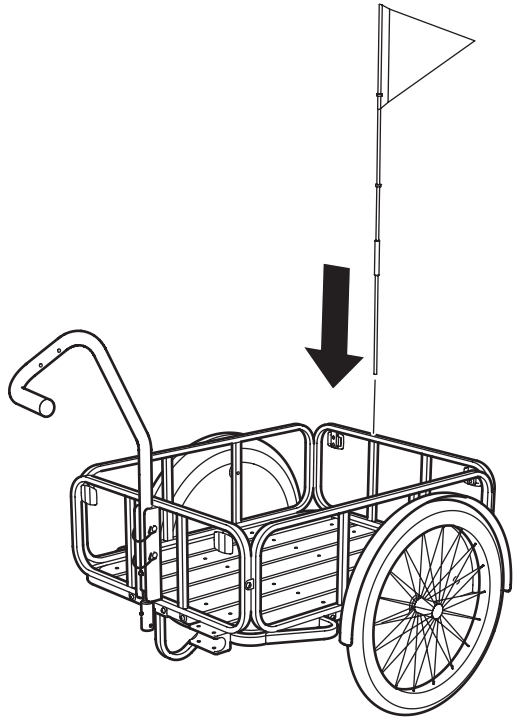

6. DE FIETSAANHANGER TESTEN VOOR GEBRUIK

Voordat je met de aanhanger gaat rijden, dien je altijd eerst een veiligheidscheck te doen op een vlakke ondergrond en op een plek waar niet veel verkeer is. Het is belangrijk dat je goed controleert of alle onderdelen goed vastzitten en juist functioneren.

CONTROLEER DE BANDEN

Zorg dat de banden de juiste bandenspanning hebben. Dat kan je het beste doen door een fietspomp met een drukmeter te gebruiken. Pomp de banden niet harder op dan de maximale bandenspanning zoals vermeld op de band. Je kan beter een hand- of een voetspomp gebruiken dan een luchtpomp. Als je de band te hard oppompt, kan hij namelijk klappen.

CONTROLEER DE REFLECTOREN

Controleer of alle reflectoren op de juiste plaats zitten.



WAARSCHUWING: Zoals alle andere mechanische componenten zal de aanhanger worden blootgesteld aan slijtage en andere beproevingen. Materialen en onderdelen kunnen verschillend reageren op slijtage. Als de levensduur van een component ten einde is, kan dit plotseling stoppen met functioneren en kan de fietser letsel oplopen. Barsten, krassen of kleurveranderingen op gebieden die aan veel belasting onderhevig zijn, kunnen erop duiden dat de levensduur van dat onderdeel ten einde is en dat dit vervangen moet worden.

INNHOLD

1. ADVARSEL	40
2. SIKKERHET	40
3. VEDLIKEHOLD	40
4. DELER	41
5. MONTER SYKKELVOGNA	42
6. TEST SYKKELVOGNA FØR BRUK	48

1. ADVARSEL



- **Advarsel!** Bremsavstanden blir lengre når du sykler og trekker en sykkelvogn.
- Passer sykkelene SLADDA 26" og 28".
- **MERK!** Hvis du vil bruke denne sykkelvogna til en annen sykkel, sørg for at du sjekker sykkelmanualen for hva som er passende beslag og vogner. Vennligst merk: Koble aldri sykkelvogna til en terrengsykkel, racersykkel, elsykkel eller annen sykkel med motor.
- SLADDA sykkelvogn er ikke egnet for å transportere barn eller dyr. Følg manualen for å montere og bruke sykkelvogna korrekt og sikkert.

2. SIKKERHET

For din egen sikkerhet, følg alltid trafikkreglene.

3. VEDLIKEHOLD

Sørg for å sjekke sykkelvognas komponenter, som skruer, beslag, ramme, reflekser og dekk regelmessig.

IKEA of Sweden AB
34381 Älmhult
Sweden

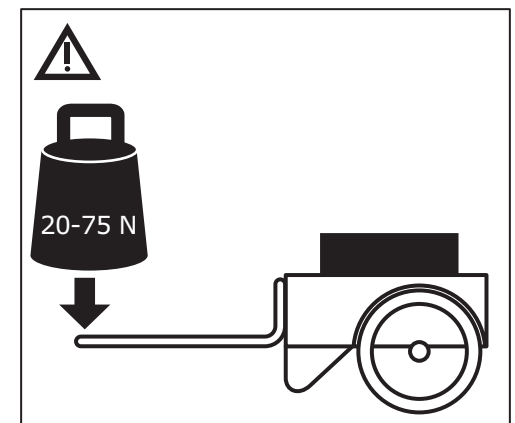
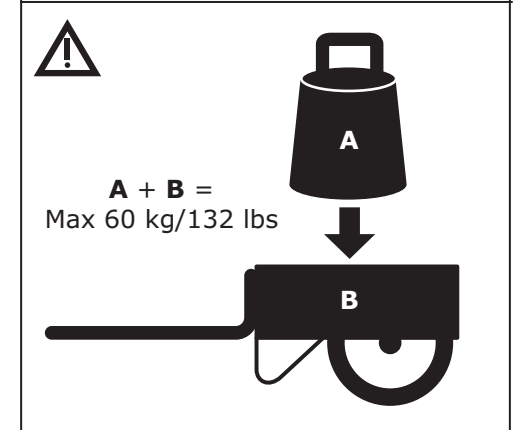
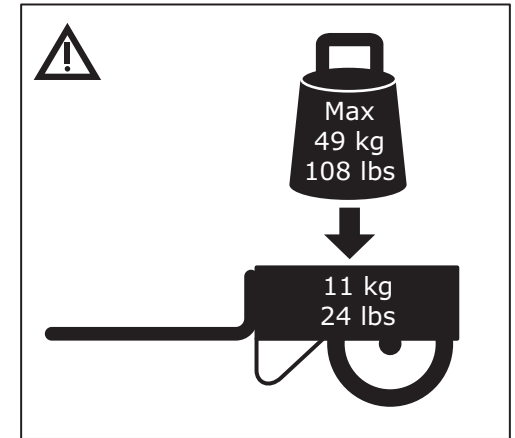

4. DELER

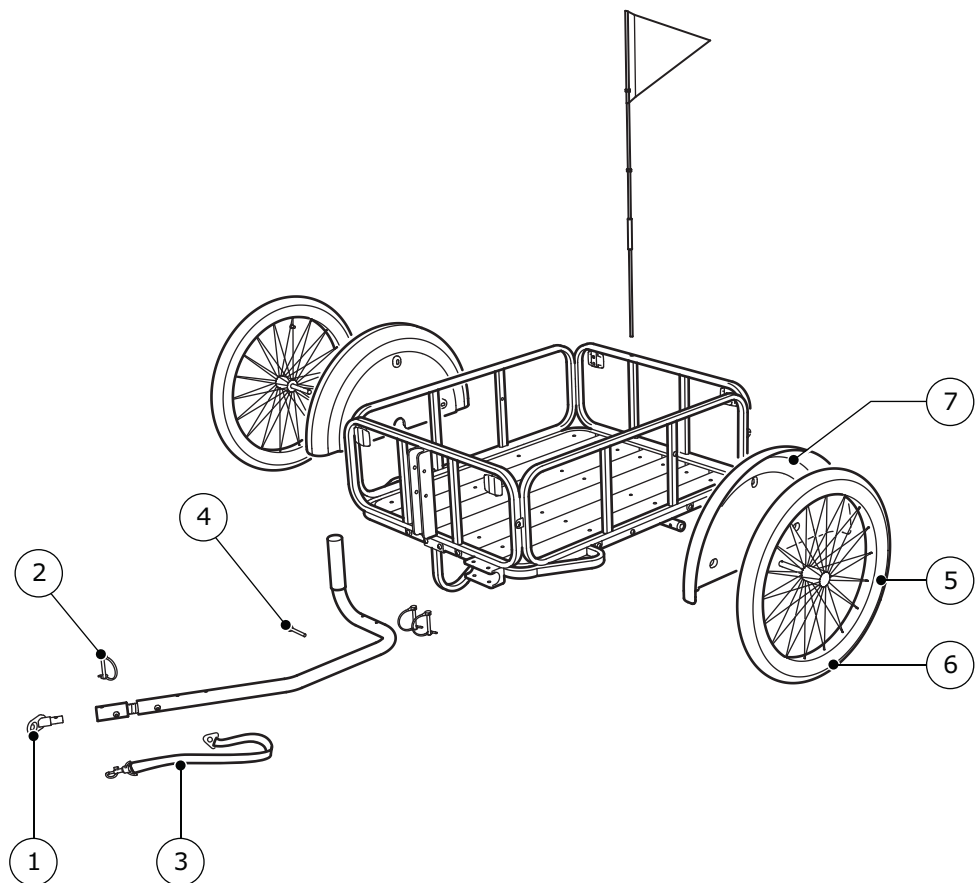

- 1 Sykkelfeste (152921)
- 2 D-formet sjakkell (152922)
- 3 Sikkerhetsreim (152923)
- 4 Skrue (152924)
- 5 Dekk, innerslange (152925)
- 6 Dekk (152926)
- 7 Skjerm (152927)

5. MONTER SYKKELVOGNA

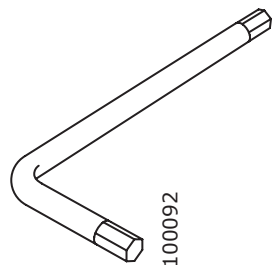
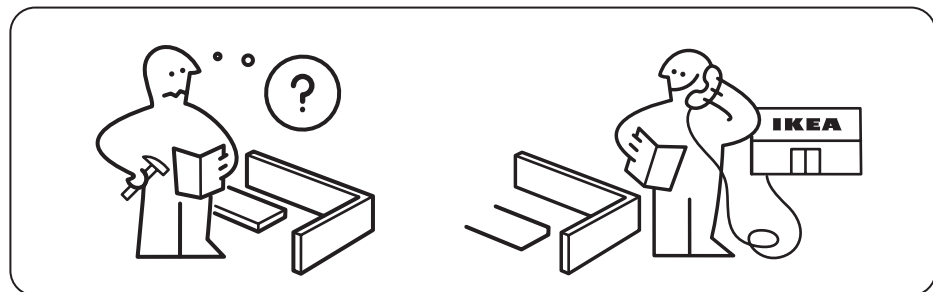
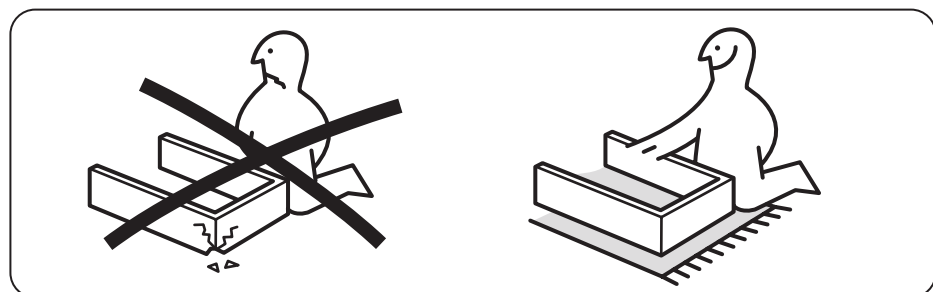
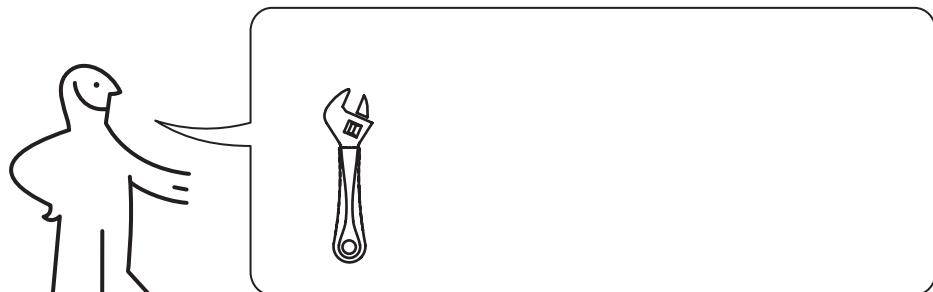

100092

1x

1

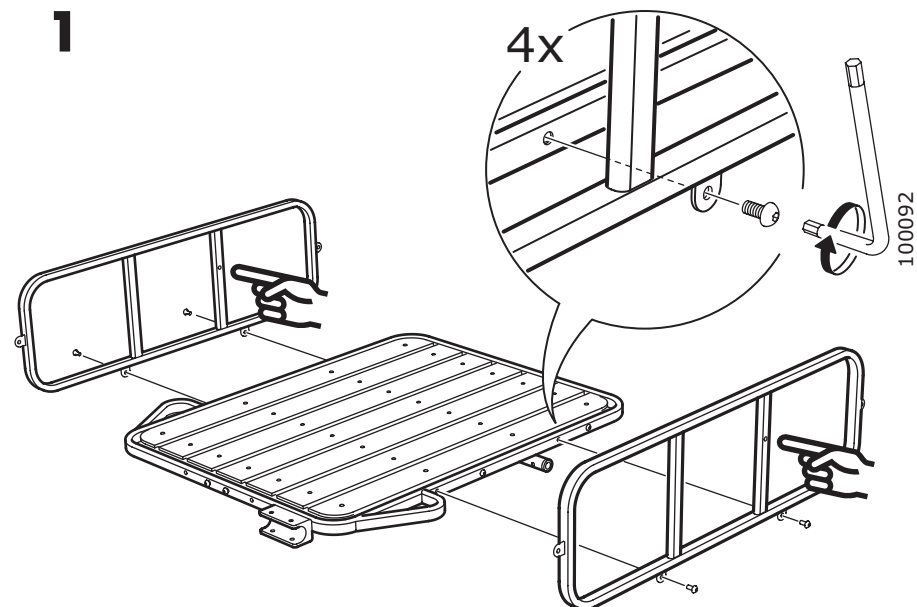

2

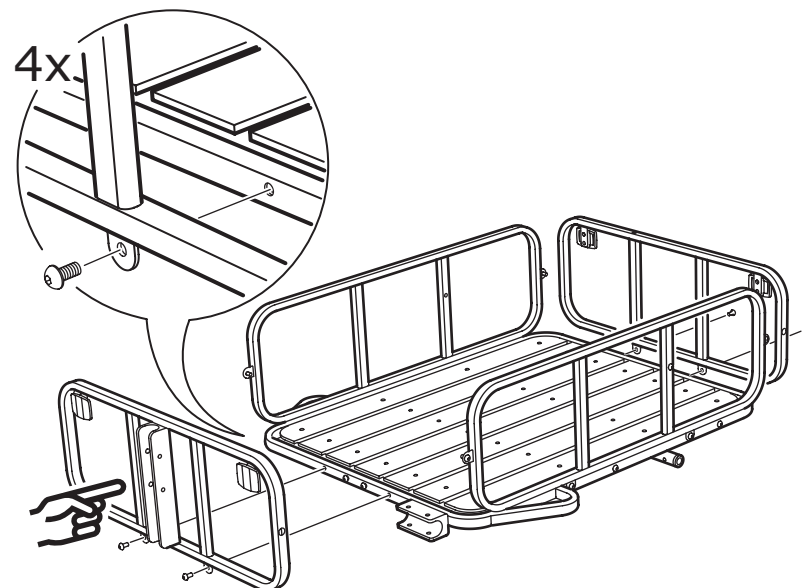

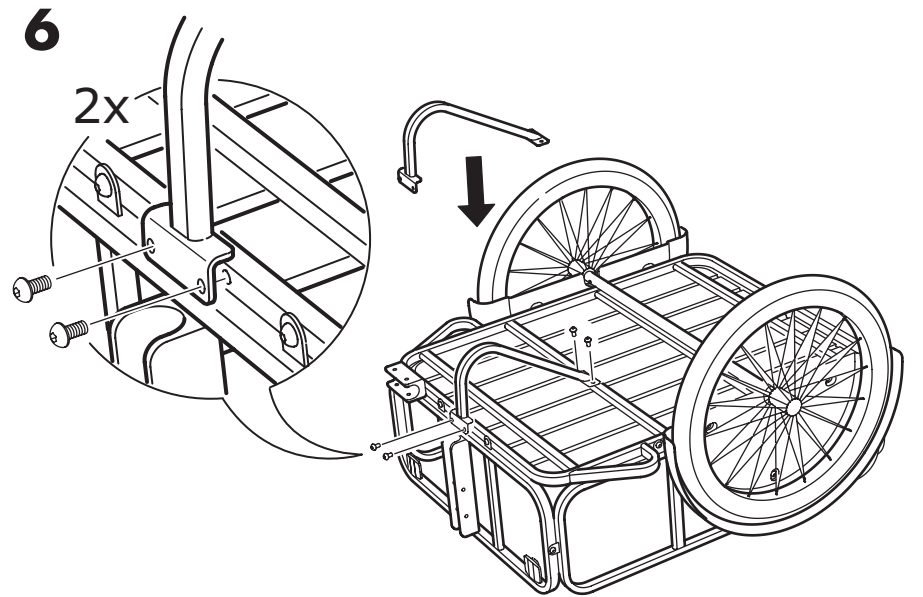
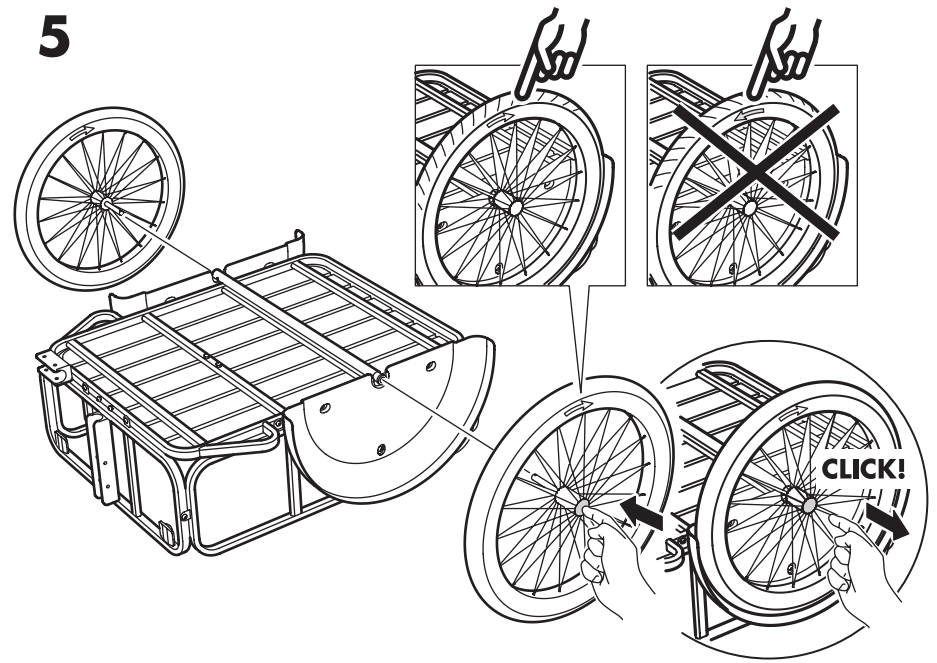
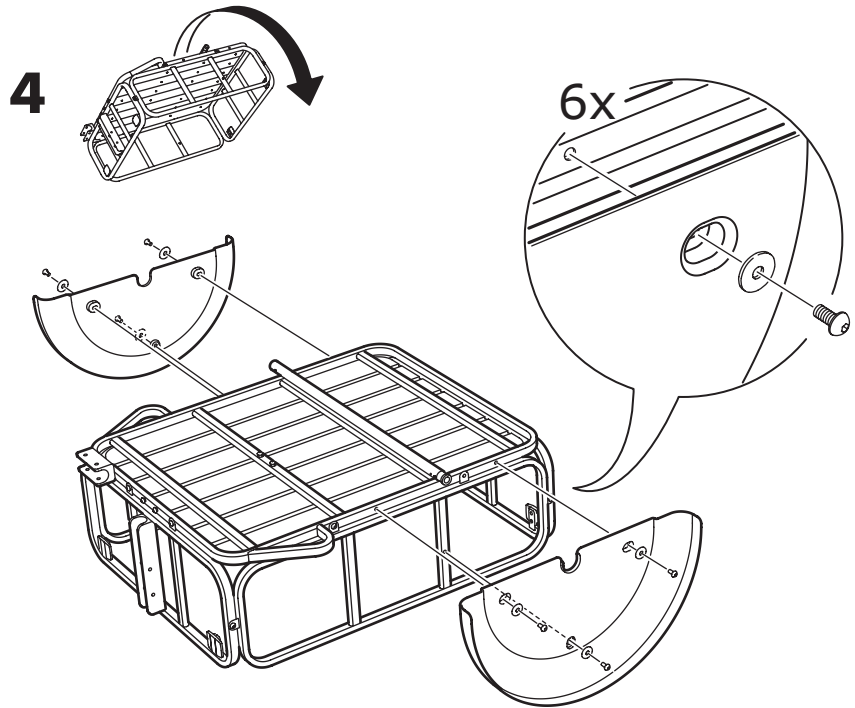
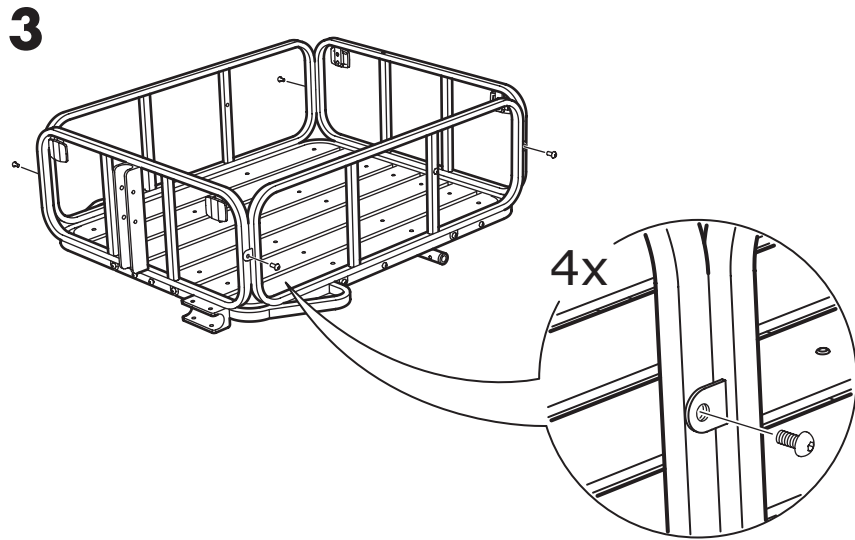

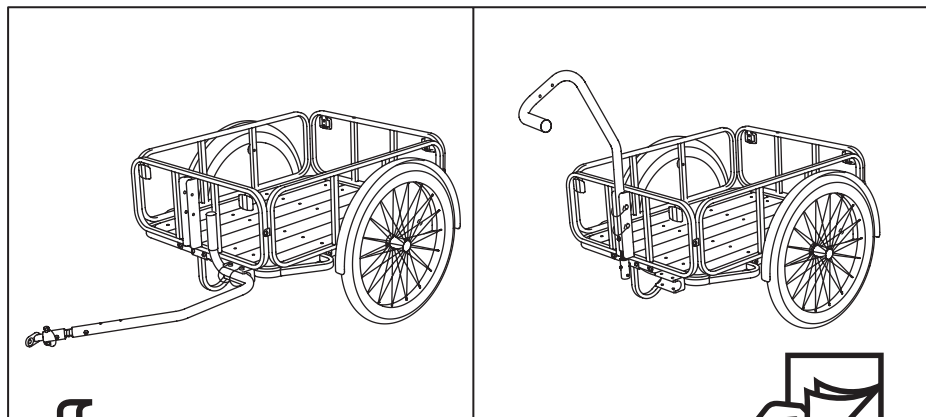

7

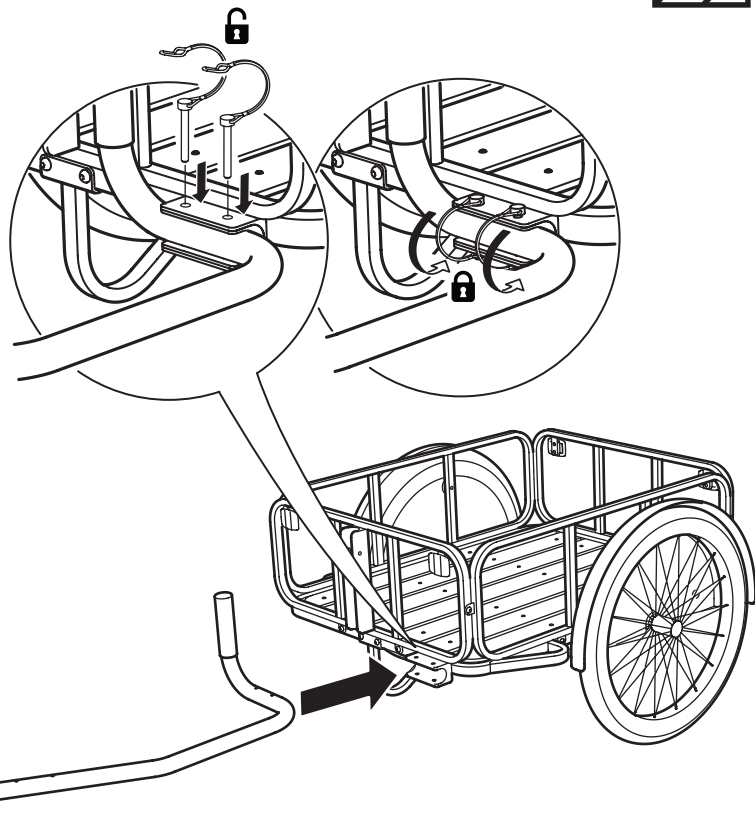

8

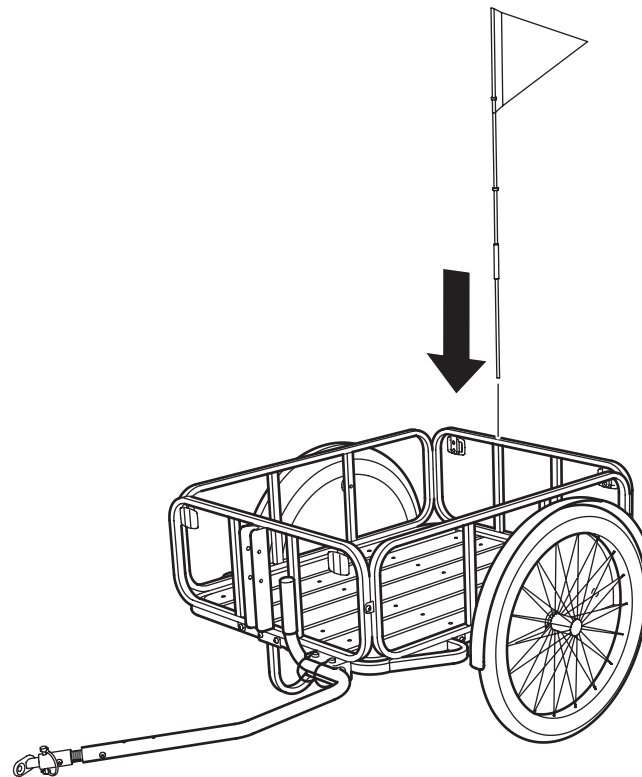

9

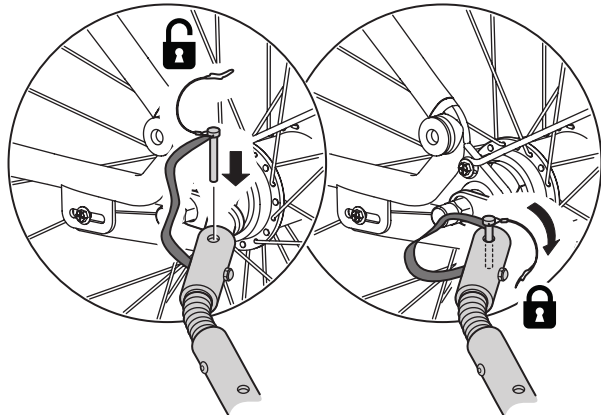
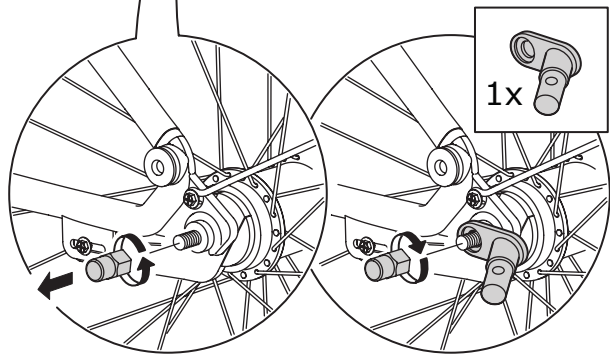
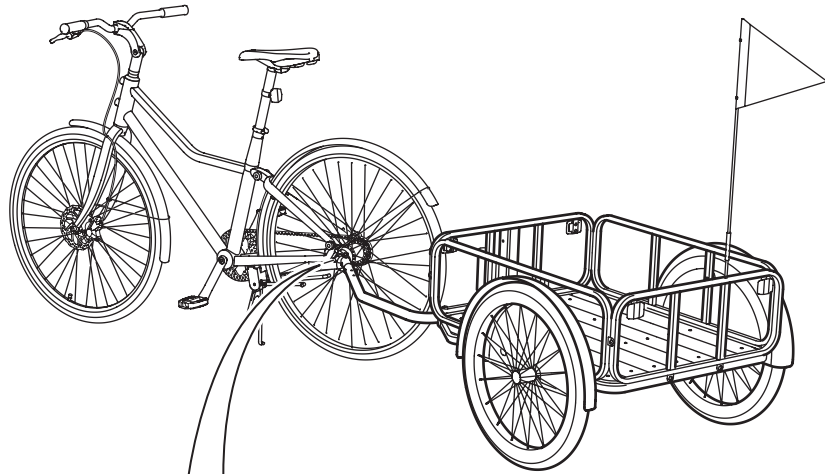

10

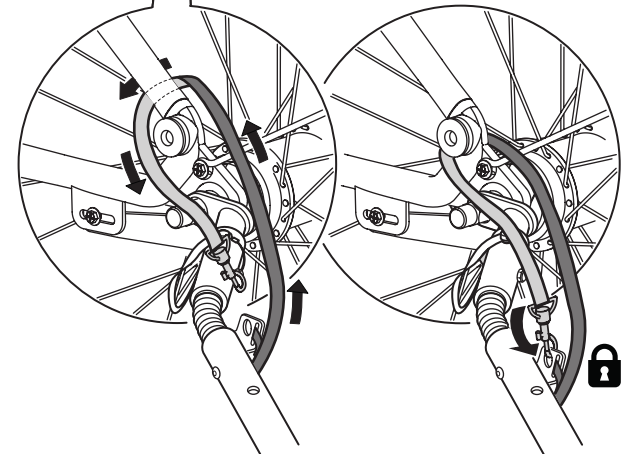
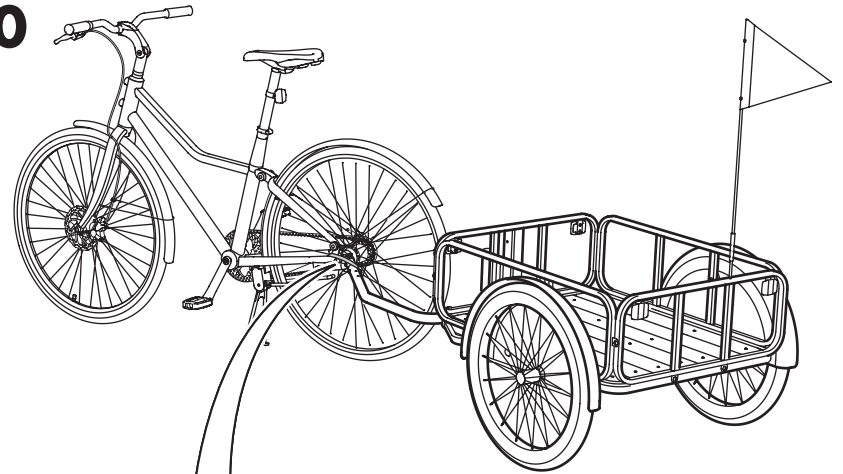

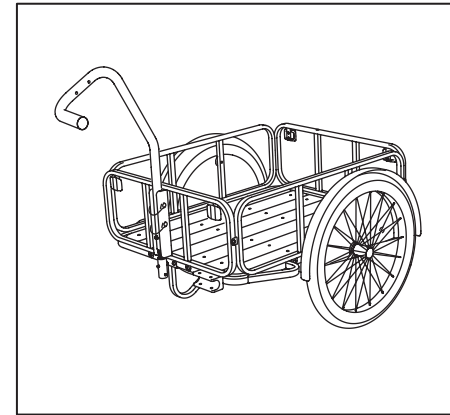
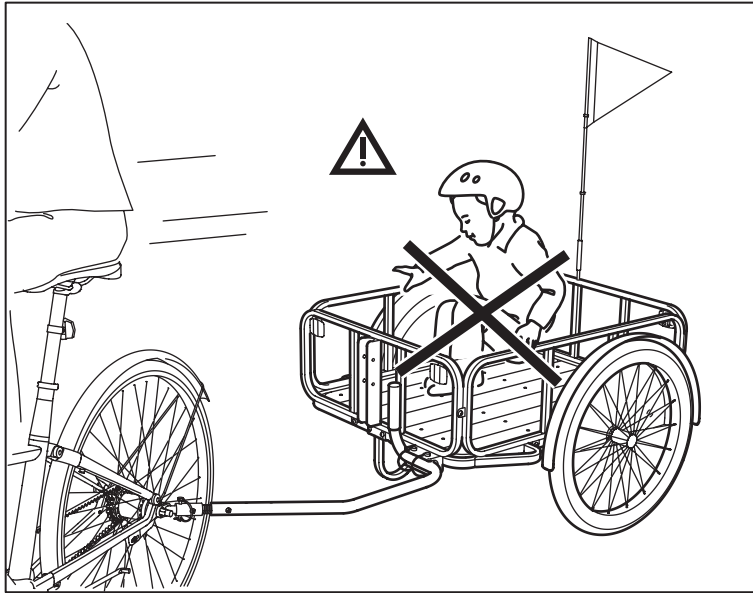

7

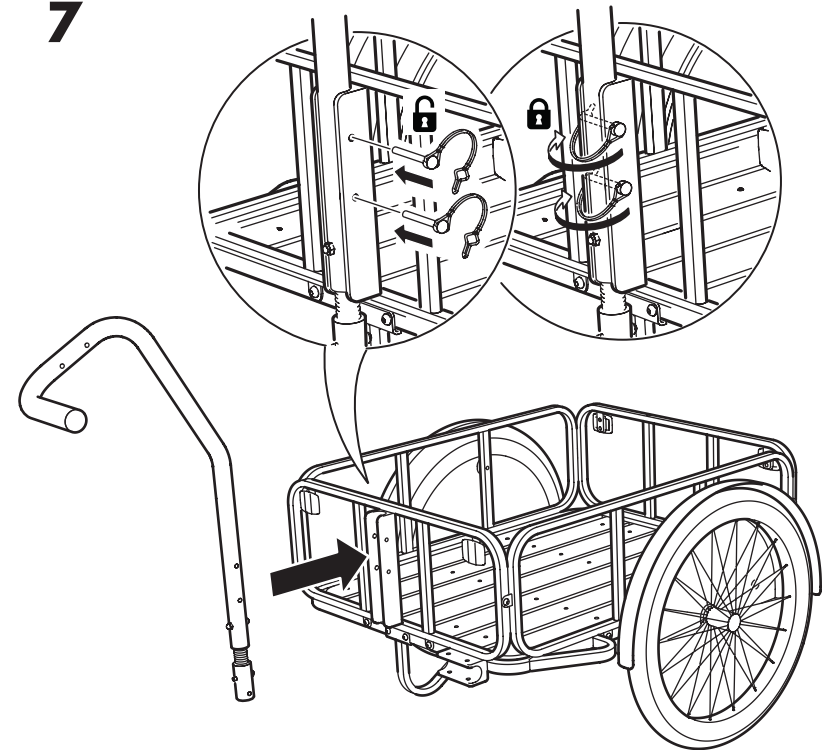

8

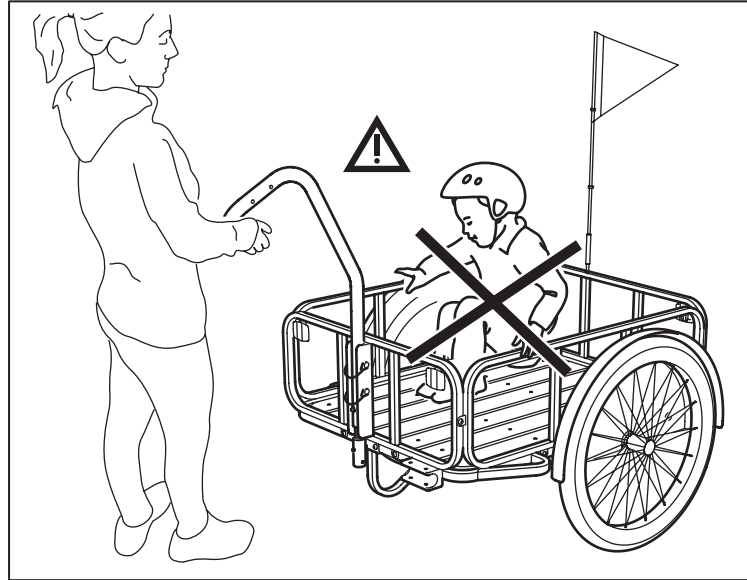
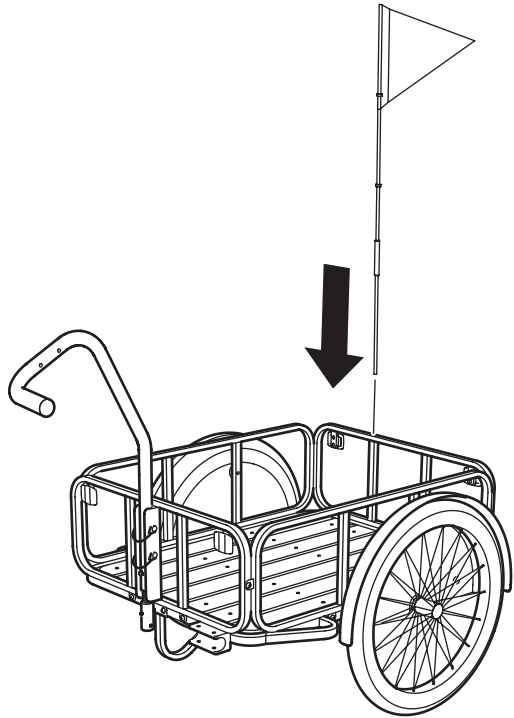

6. TEST SYKKELVOGNA FØR BRUK

Før du bruker sykkelvogna, bør du utføre en sikkerhetssjekk på jevnt underlag og skjermet for trafikk. Det er viktig at du sikrer at alle deler er festet riktig og fungerer som de skal.

KONTROLLER DEKKENE

Sørg for at dekkene er fylt opp med luft til anbefalt trykknivå. Bruk en dekkpumpe med lufttryksmåler. Trykket må ikke overstige den anbefalte grensen som står på dekkene. Det er bedre å bruke en hånd- eller fotpumpe enn en dekkpumpe på en bensinstasjon, siden overfylling kan ødelegge dekkene.

KONTROLLER REFLEKSENE

Sjekk at refleksene er plassert riktig.



ADVARSEL! Som med alle mekaniske komponenter, utsettes sykkelvogna for slitasje og belastning. Ulike materialer og komponenter kan reagere forskjellig på slitasje og materialtrøtthet. Dersom maksimal levetid til en komponent er nådd, kan den plutselig svikte og påføre syklisten skade. Alle former for sprekker, riper eller fargeendring i sterkt belastede områder indikerer at slutten på komponentens levetid er nådd, og den må erstattes.

INDICE

1. AVVERTENZE	49
2. SICUREZZA	49
3. MANUTENZIONE	49
4. COMPONENTI	50
5. MONTAGGIO DEL RIMORCHIO	51
6. CONTROLLO DEL RIMORCHIO PRIMA DELL'USO	57

1. AVVERTENZA



- **Avvertenza!** Quando utilizzi un rimorchio per bicicletta, la distanza di frenata aumenta.
- Utilizzabile con la bicicletta SLADDA da 26" e 28".
- **N.B.** Prima di usare questo rimorchio con un'altra bicicletta, consulta il relativo manuale di istruzioni per verificare quali sono gli accessori di montaggio e i rimorchi compatibili. N.B.: non agganciare mai questo rimorchio a mountain bike, biciclette da corsa, biciclette elettriche o a pedalata assistita.
- Il rimorchio per bicicletta SLADDA non è adatto al trasporto di bambini e animali. Segui il manuale di istruzioni per montare e utilizzare il rimorchio in maniera corretta e sicura.

2. SICUREZZA

Per la tua sicurezza, rispetta sempre il codice della strada.

3. MANUTENZIONE

Controlla regolarmente i componenti del rimorchio, come viti, accessori di montaggio, telaio, catarifrangenti e gomme.

IKEA of Sweden AB
34381 Älmhult
Sweden

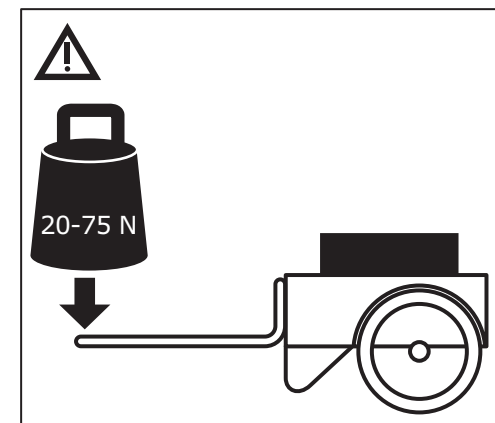
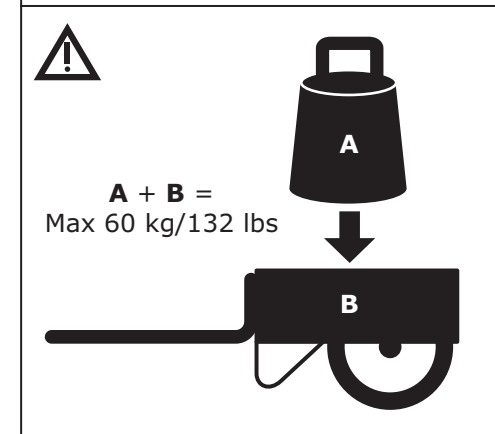
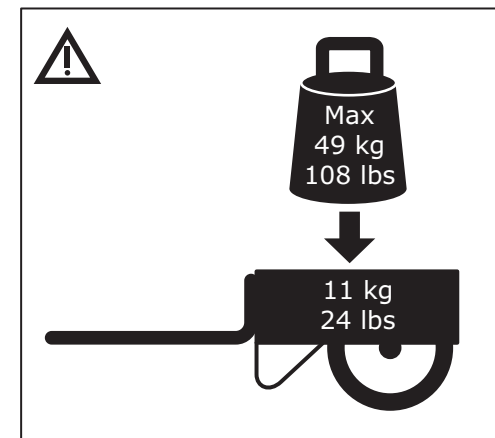

4. COMPONENTI

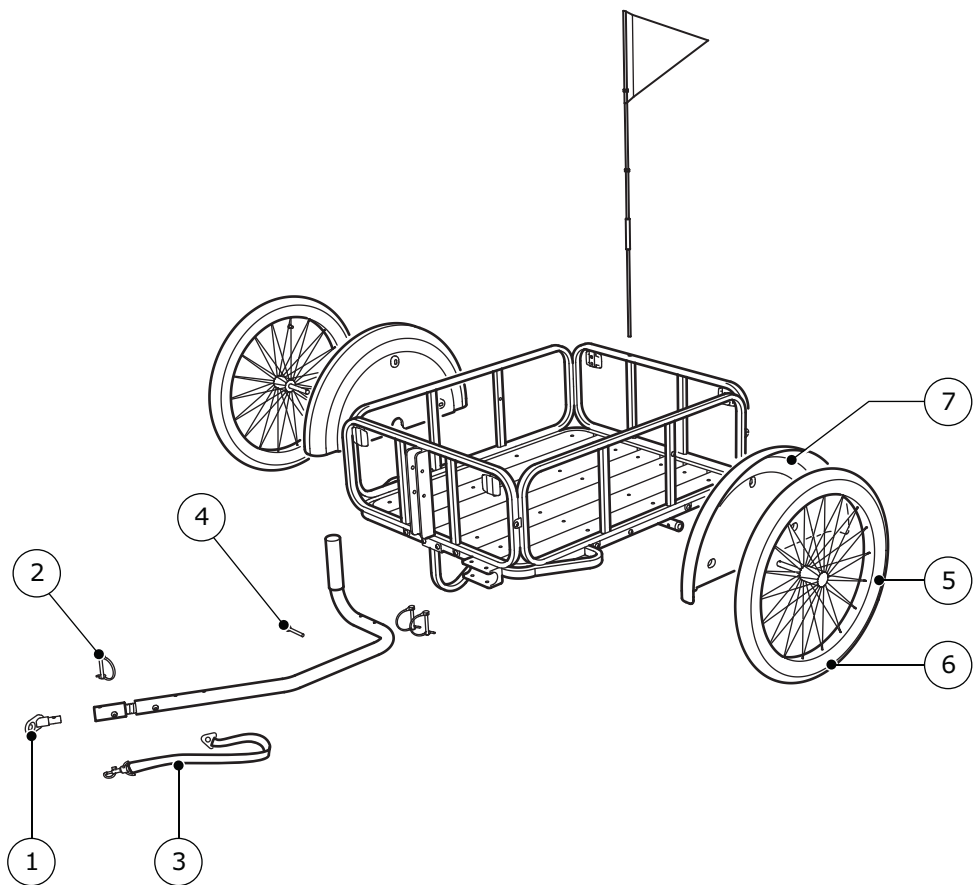

- 1 Raccordo (152921)
- 2 Perno di sicurezza (152922)
- 3 Cinghia di sicurezza (152923)
- 4 Vite M5 (152924)
- 5 Gomma, camera d'aria (152925)
- 6 Gomma (152926)
- 7 Parafango (152927)

5. MONTAGGIO DEL RIMORCHIO

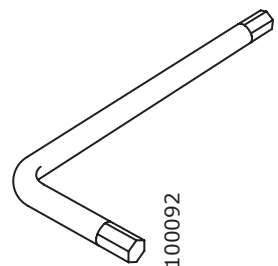
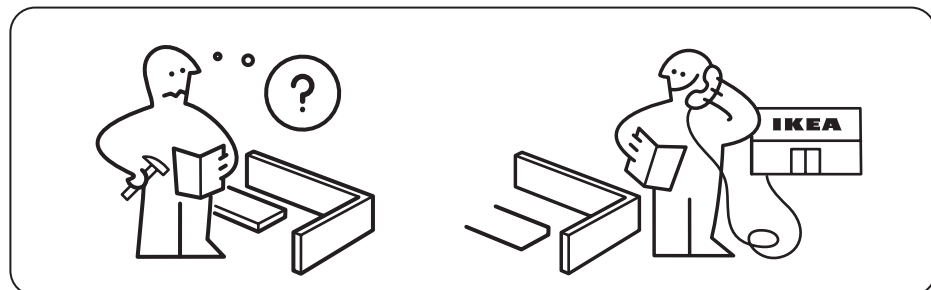
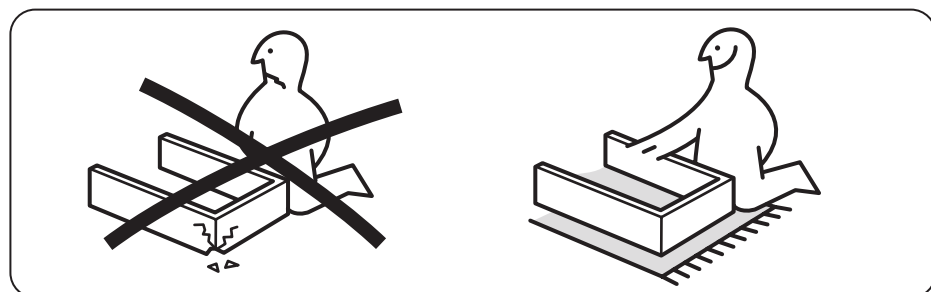
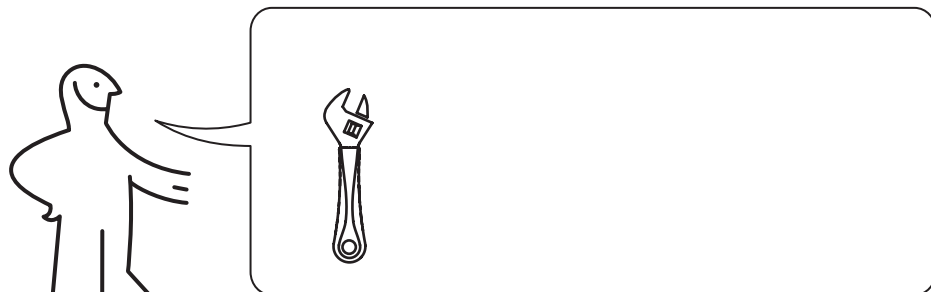

1x

100092

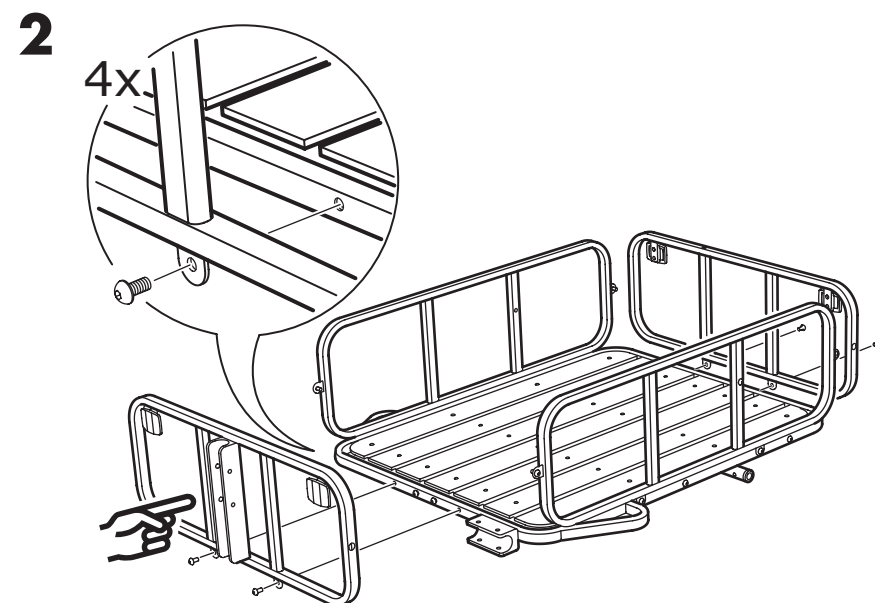
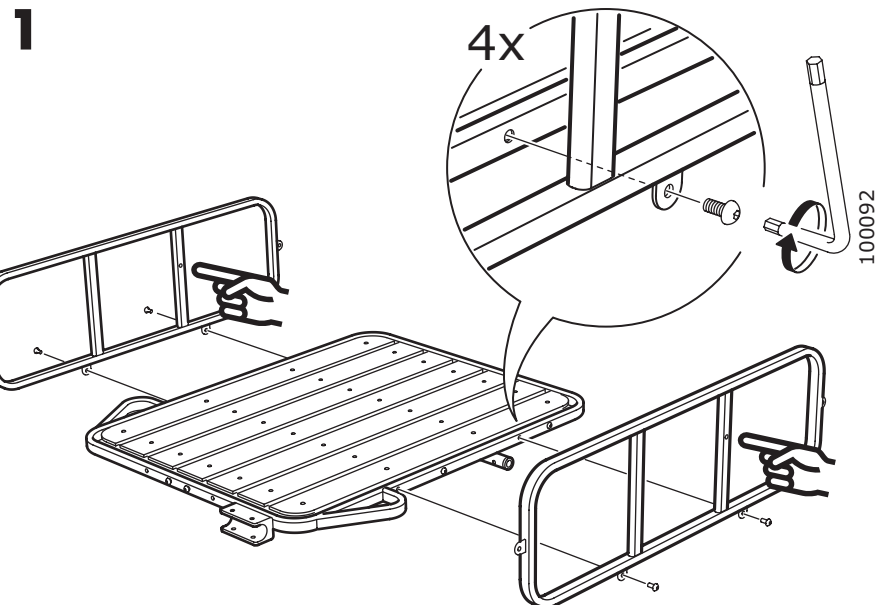

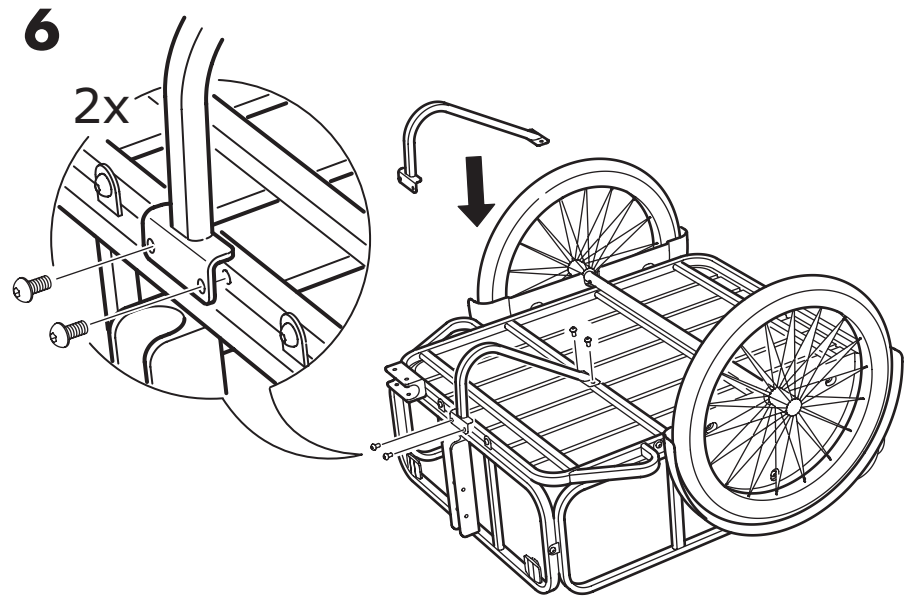
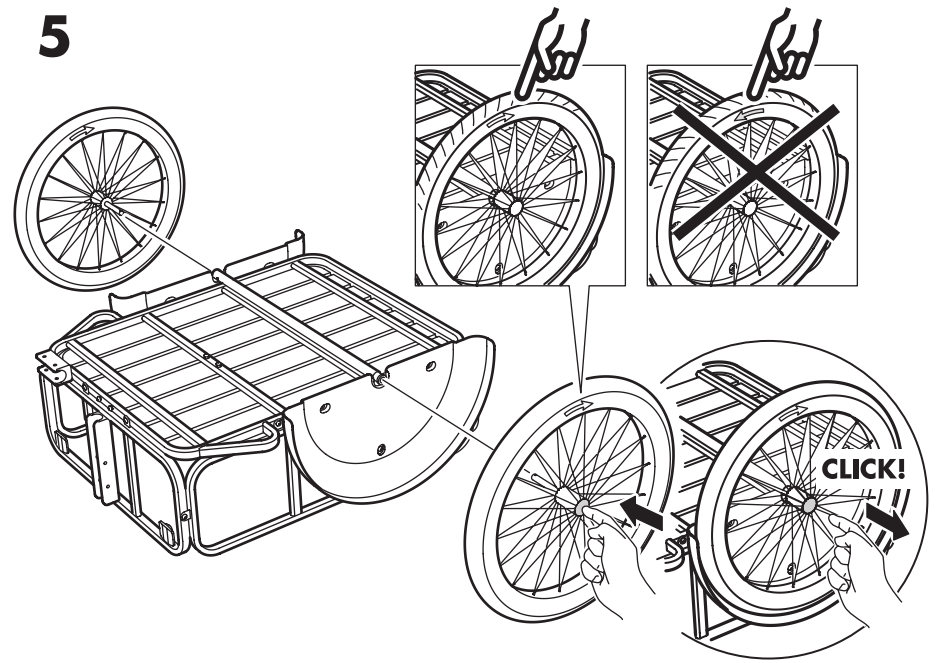
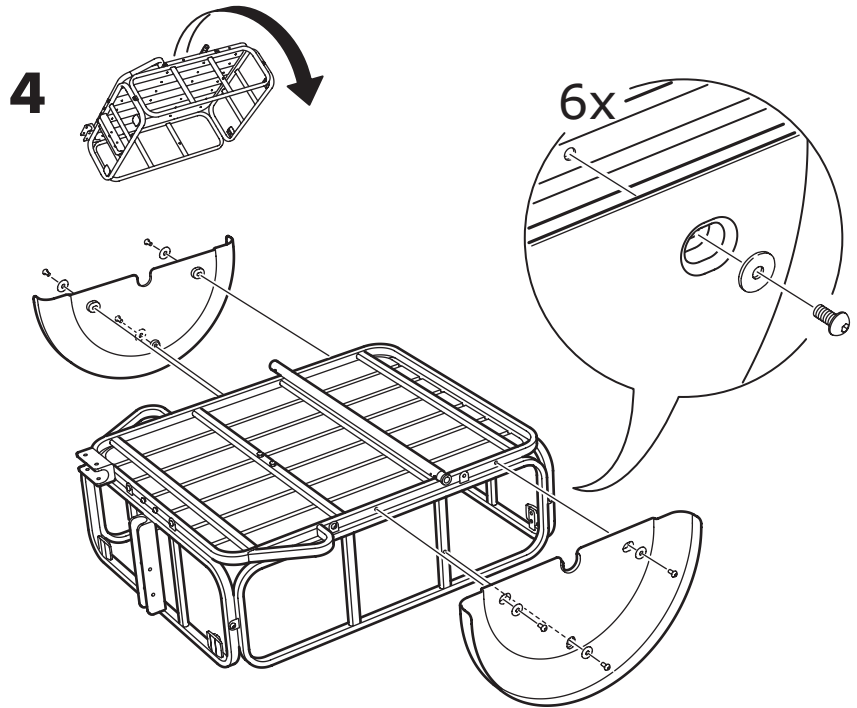
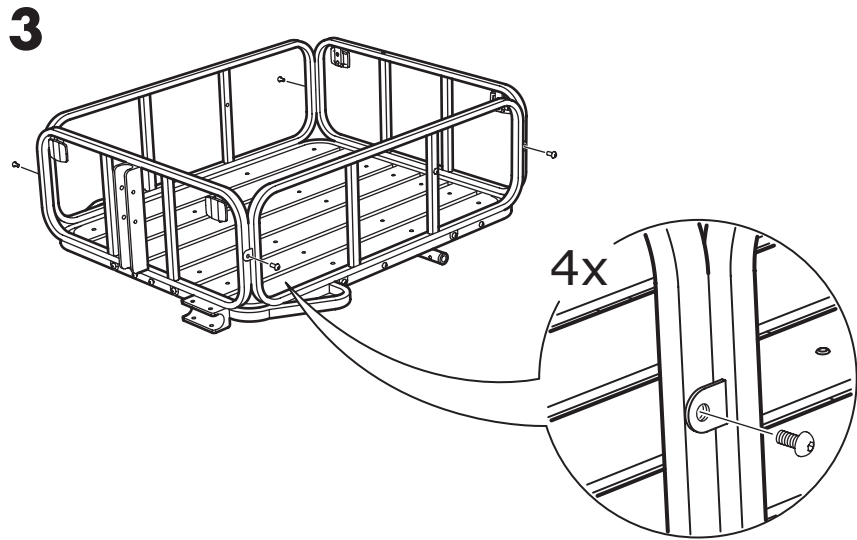

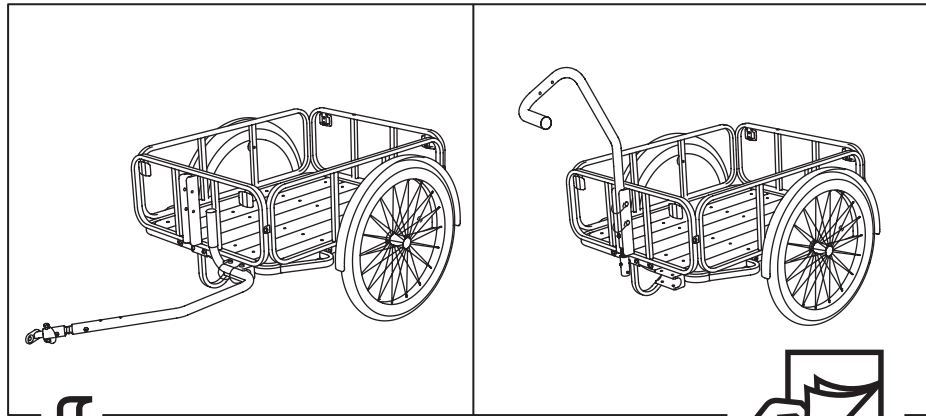

7

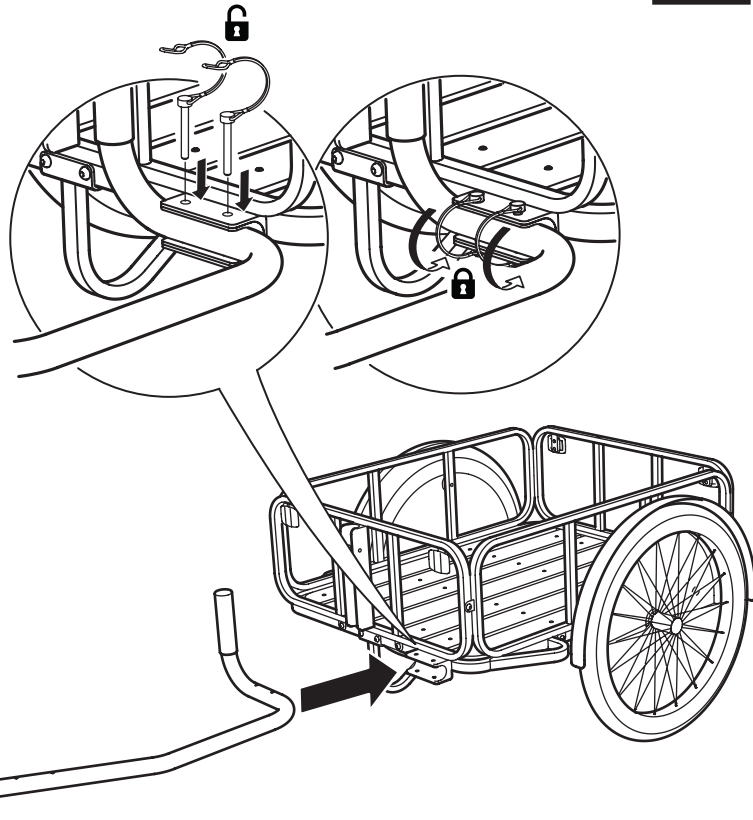

8

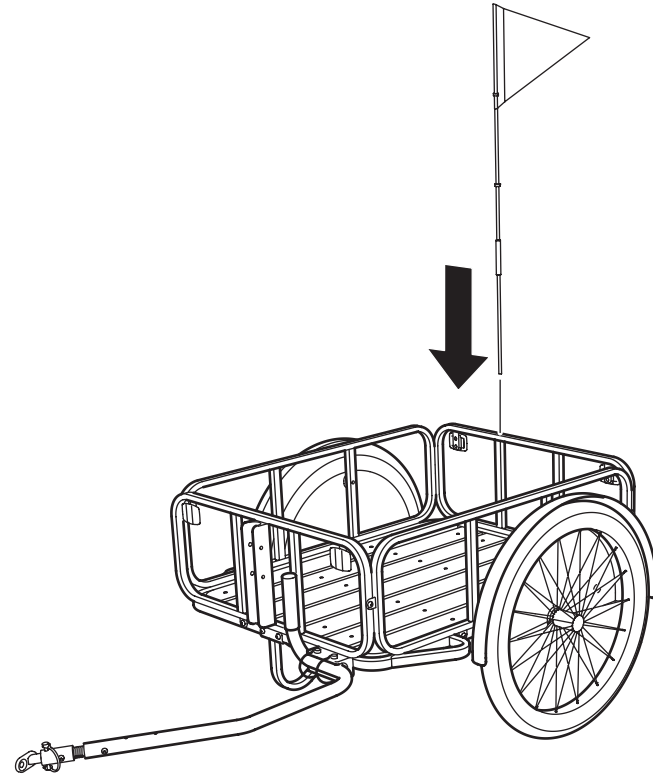

9

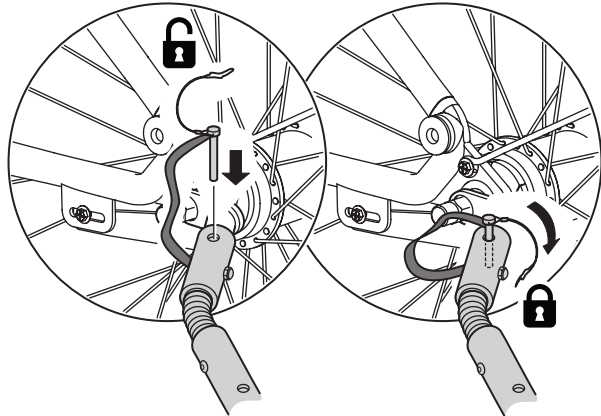
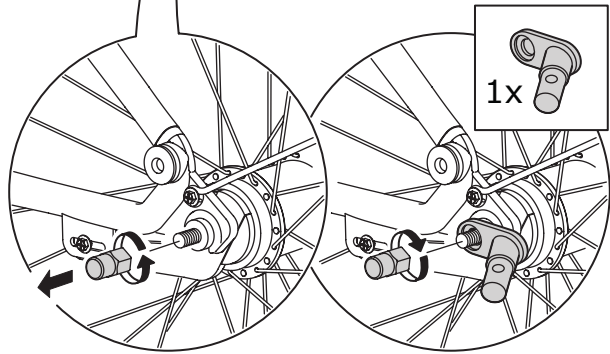
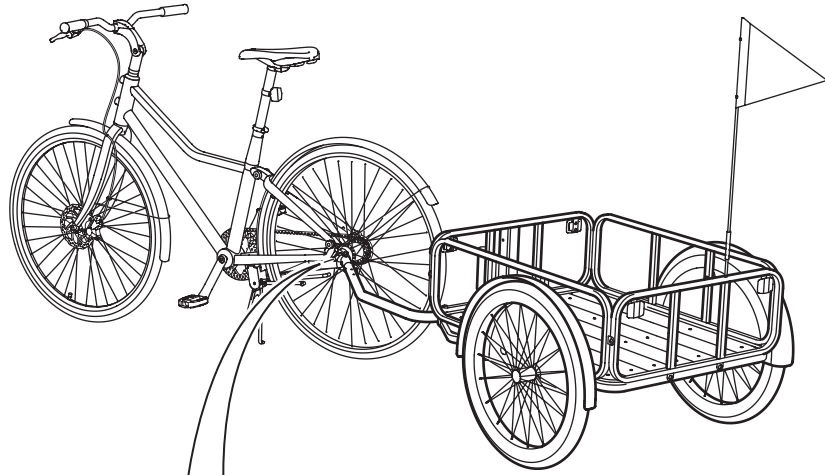

10

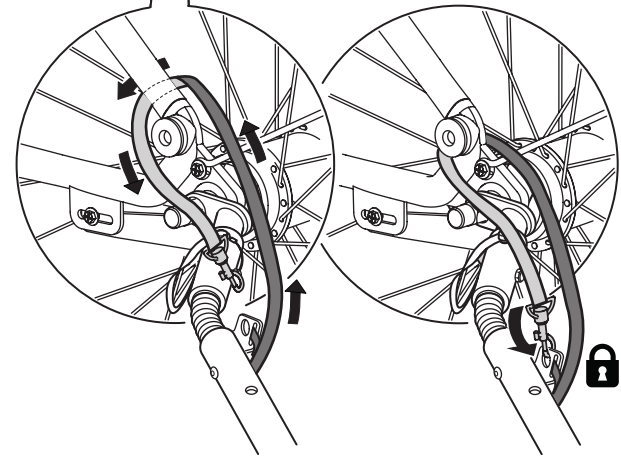
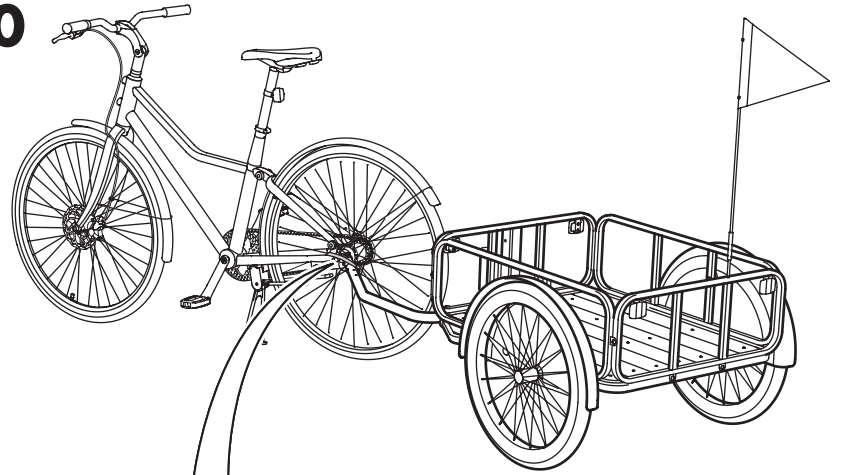

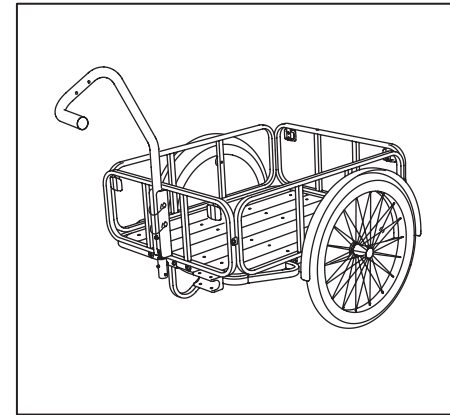
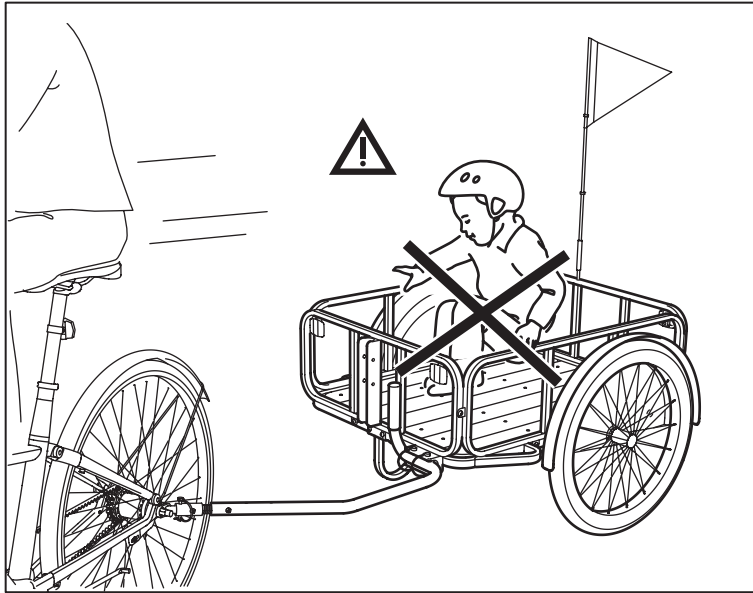

7

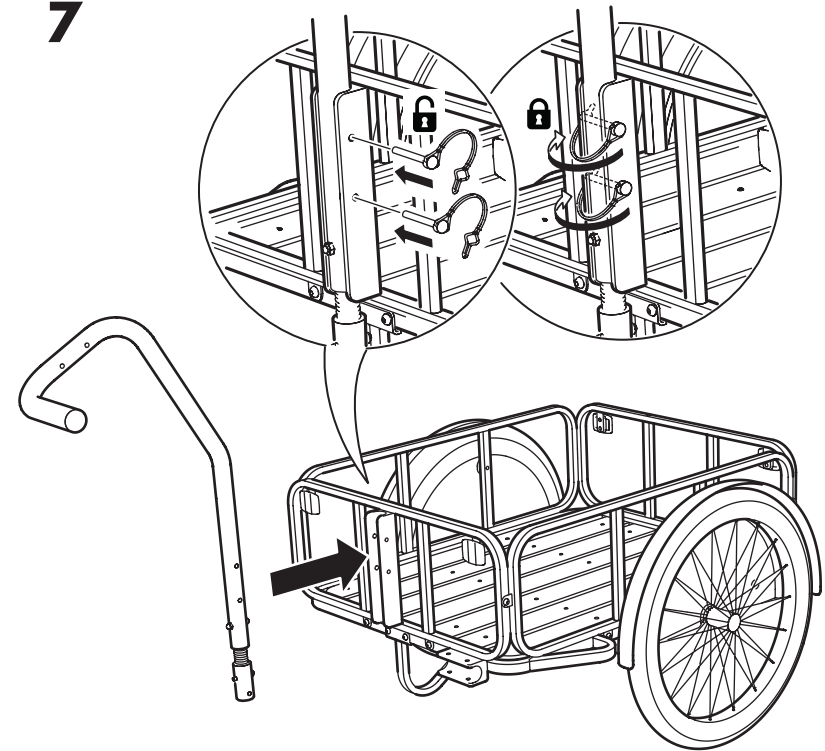

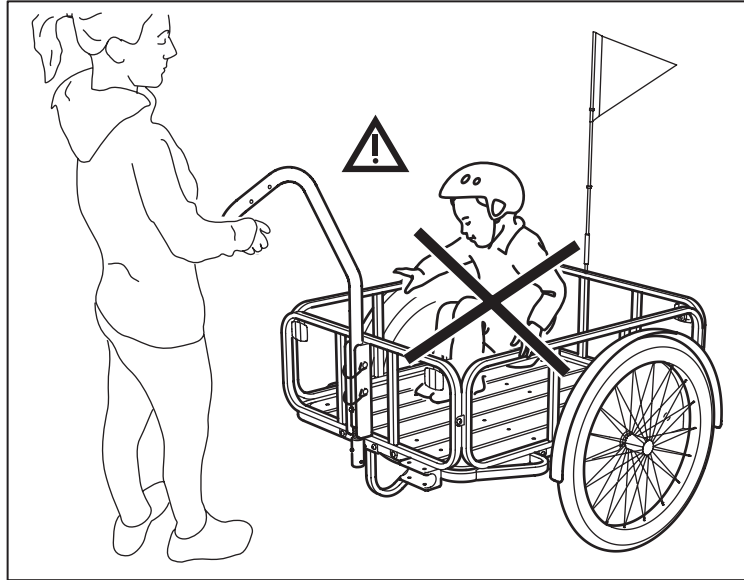
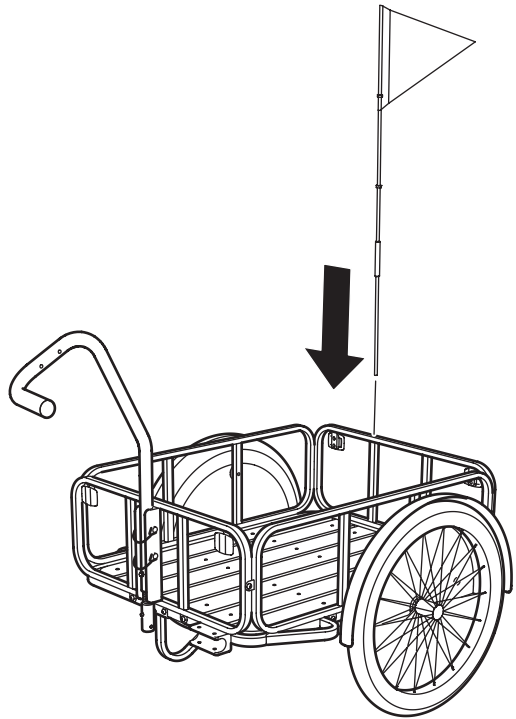

6. CONTROLLO DEL RIMORCHIO PRIMA DELL'USO

Prima di usare il rimorchio, effettua un controllo di sicurezza su un terreno in piano, lontano dal traffico. È importante verificare che tutti i componenti siano ben fissati e che funzionino correttamente.

CONTROLLO DELLE GOMME

Assicurati di gonfiare le gomme alla pressione raccomandata usando una pompa con manometro. La pressione non deve superare il limite riportato sulla gomma. È preferibile utilizzare una pompa a mano o a pedale anziché il compressore di una stazione di servizio, poiché un gonfiaggio eccessivo potrebbe far scoppiare la gomma.

CONTROLLO DEI CATARIFRANGENTI

Controlla che i catarifrangenti siano posizionati correttamente.



AVVERTENZE! *Come tutti i componenti meccanici, il rimorchio per bicicletta è soggetto a usura. I vari materiali e componenti possono reagire in modo diverso all'usura. I componenti che hanno superato il periodo di durata previsto potrebbero rompersi, provocando lesioni a chi utilizza la bicicletta. Eventuali spaccature, graffi o alterazioni del colore in aree soggette a forte usura indicano che il componente ha raggiunto la propria durata massima e deve essere sostituito.*

ΠΕΡΙΕΧΟΜΕΝΑ

1. ΠΡΟΕΙΔΟΠΟΙΗΣΗ	58
2. ΑΣΦΑΛΕΙΑ	58
3. ΦΡΟΝΤΙΔΑ ΚΑΙ ΣΥΝΤΗΡΗΣΗ	58
4. ΑΝΤΑΛΛΑΚΤΙΚΑ & ΕΞΑΡΤΗΜΑΤΑ	59
5. ΣΥΝΑΡΜΟΛΟΓΗΣΗ ΤΟΥ ΤΡΕΙΛΕΡ	60
6. ΕΛΕΓΧΟΣ ΠΡΙΝ ΑΠΟ ΤΗ ΧΡΗΣΗ ΤΟΥ ΤΡΕΙΛΕΡ	66

1. ΠΡΟΕΙΔΟΠΟΙΗΣΗ



- **Προειδοποίηση!** Η απόσταση φρεναρίσματος σας θα αυξηθεί όταν κάνετε ποδήλατο με ένα τρέιλερ.
- Ταιριάζει στο ποδήλατο SLADDA 26" και 28".
- **ΣΗΜΕΙΩΣΗ!** Αν θέλετε να χρησιμοποιήσετε αυτό το τρέιλερ με ένα διαφορετικό ποδήλατο, πρέπει πρώτα να ελέγξετε το εγχειρίδιο του ποδηλάτου για τα κατάλληλα εξαρτήματα και τα τρέιλερ. Παρακαλώ σημειώστε! Ποτέ μη συνδέετε το τρέιλερ σε ένα ποδήλατο βουνού, ένα αγωνιστικό ποδήλατο, ένα ηλεκτρικό ποδήλατο ή οποιοδήποτε άλλο ποδήλατο που έχει ενίσχυση μοτέρ.
- Το τρέιλερ SLADDA δεν είναι κατάλληλο για τη μεταφορά παιδιών ή ζώων. Ακολουθήστε τις οδηγίες για να συναρμολογήσετε και να χρησιμοποιήσετε το τρέιλερ με σωστό και ασφαλή τρόπο.

2. ΑΣΦΑΛΕΙΑ

Για τη δική σας ασφάλεια, να ακολουθείτε πάντα τους κανόνες οδικής κυκλοφορίας στη χώρα σας.

3. ΦΡΟΝΤΙΔΑ ΚΑΙ ΣΥΝΤΗΡΗΣΗ

Βεβαιωθείτε ότι ελέγχετε τακτικά τα μέρη του τρέιλερ, όπως βίδες συναρμολόγησης, εξαρτήματα, σκελετό, ανακλαστικά και λάστιχα.

IKEA of Sweden AB
34381 Älmhult
Sweden

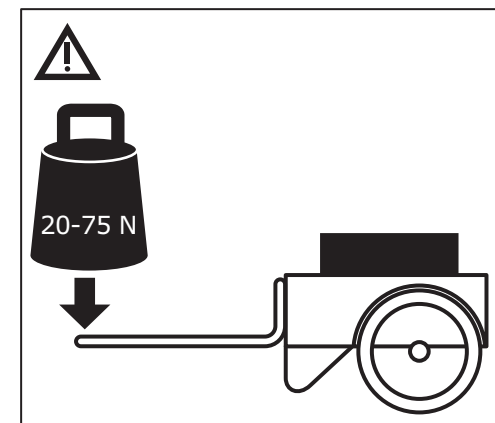
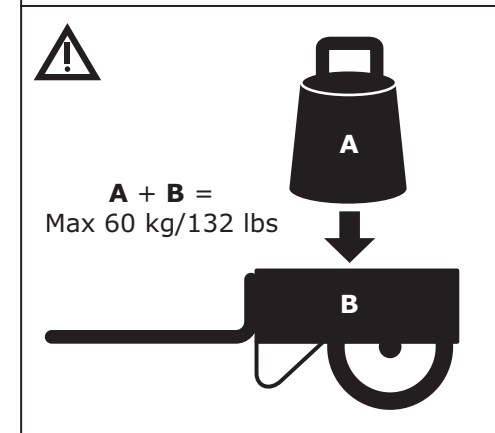
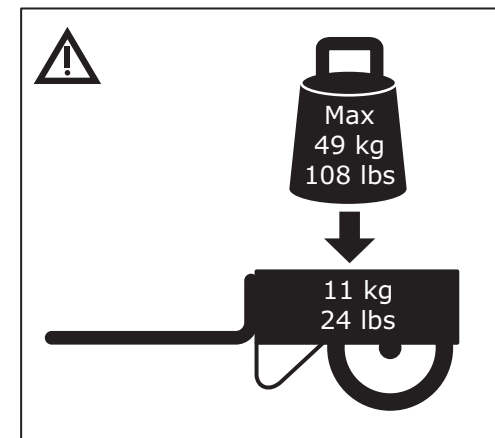

4. ΑΝΤΑΛΛΑΚΤΙΚΑ & ΕΞΑΡΤΗΜΑΤΑ

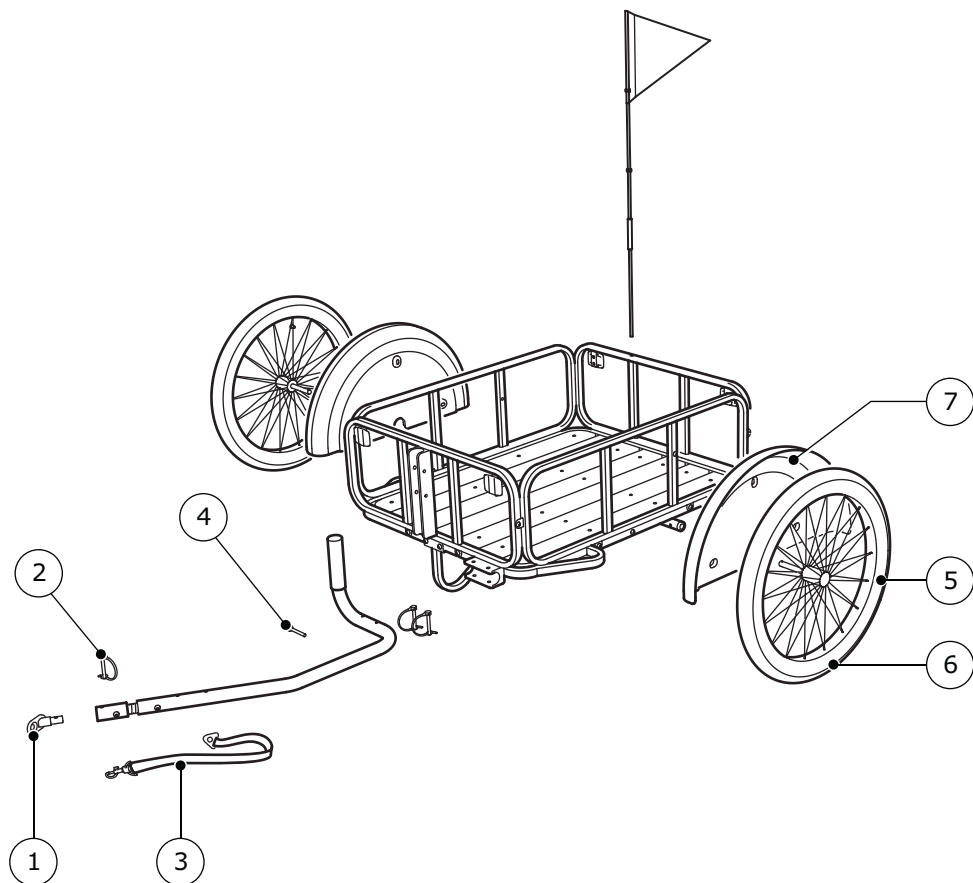

- 1 Εξάρτημα σύνδεσης (152921)
- 2 Εξάρτημα κλειδώματος σε σχήμα D (152922)
- 3 Ιμάντας ασφαλείας (152923)
- 4 Βίδα M5 (152924)
- 5 Λάστιχο, συμπίεση (152925)
- 6 Λάστιχο (152926)
- 7 Φτερό (152927)

5. ΣΥΝΑΡΜΟΛΟΓΗΣΗ ΤΟΥ ΤΡΕΙΛΕΡ

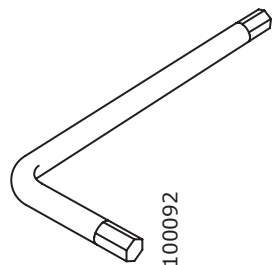
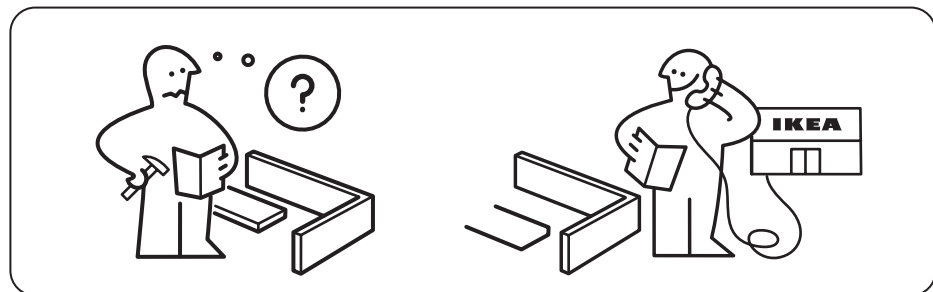
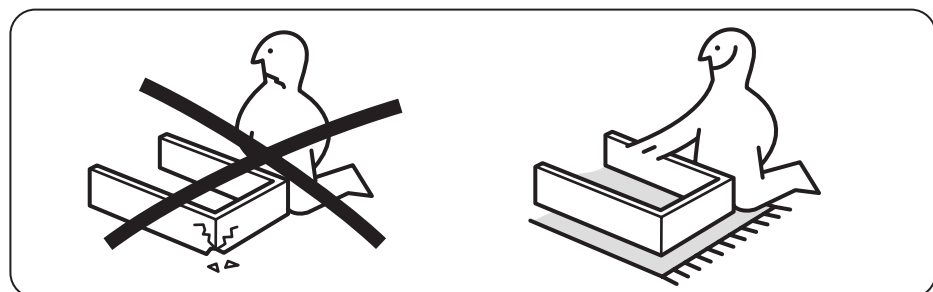
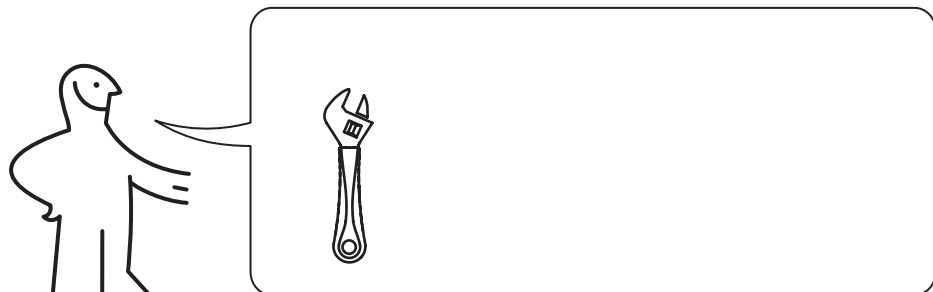

100092

1x

1

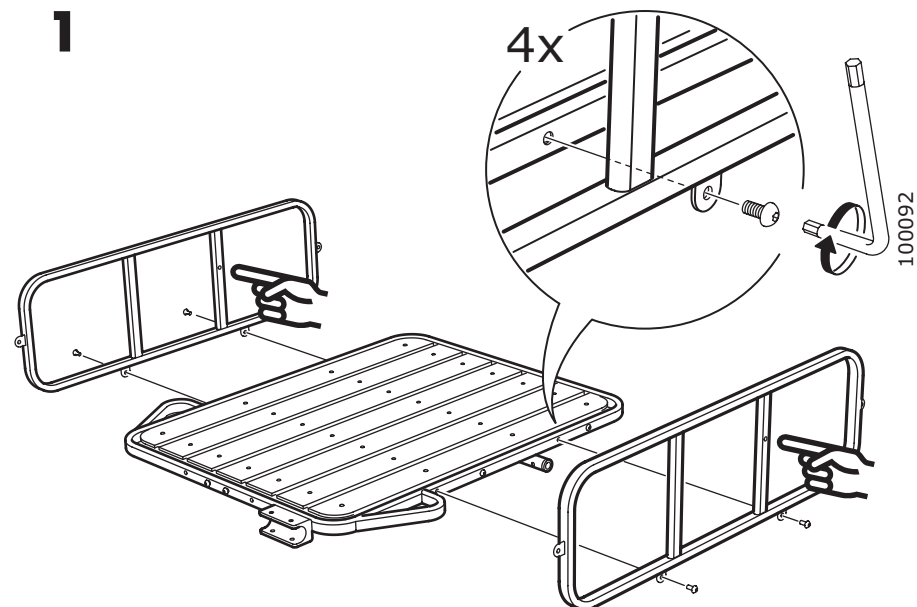

2

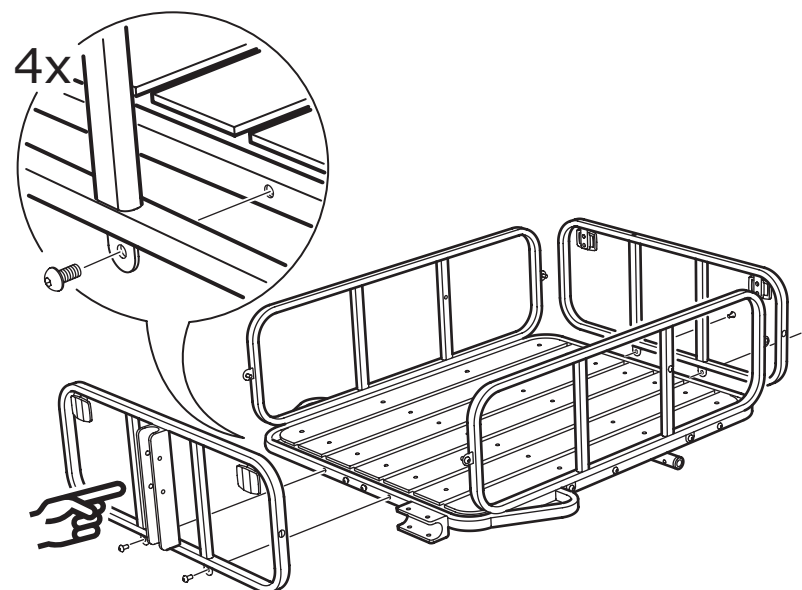

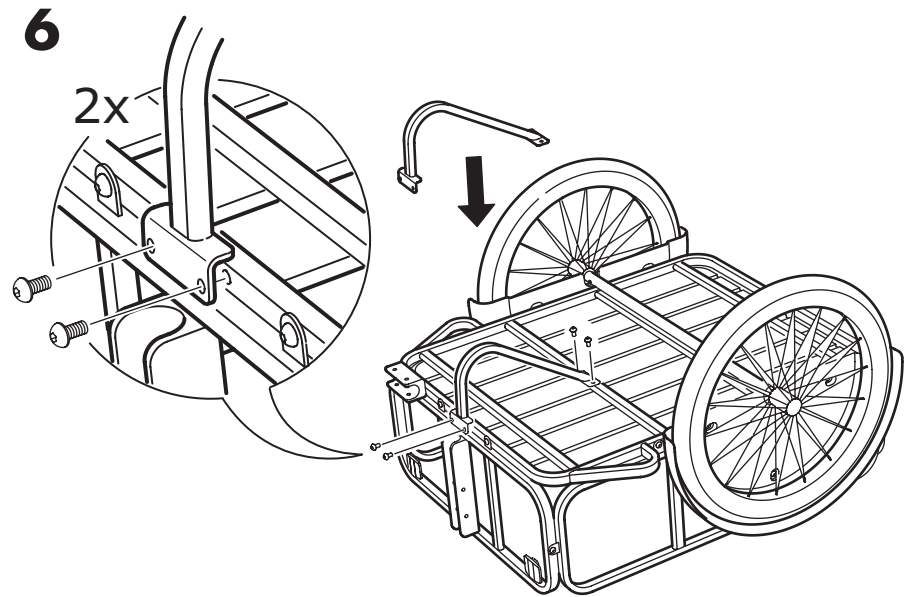
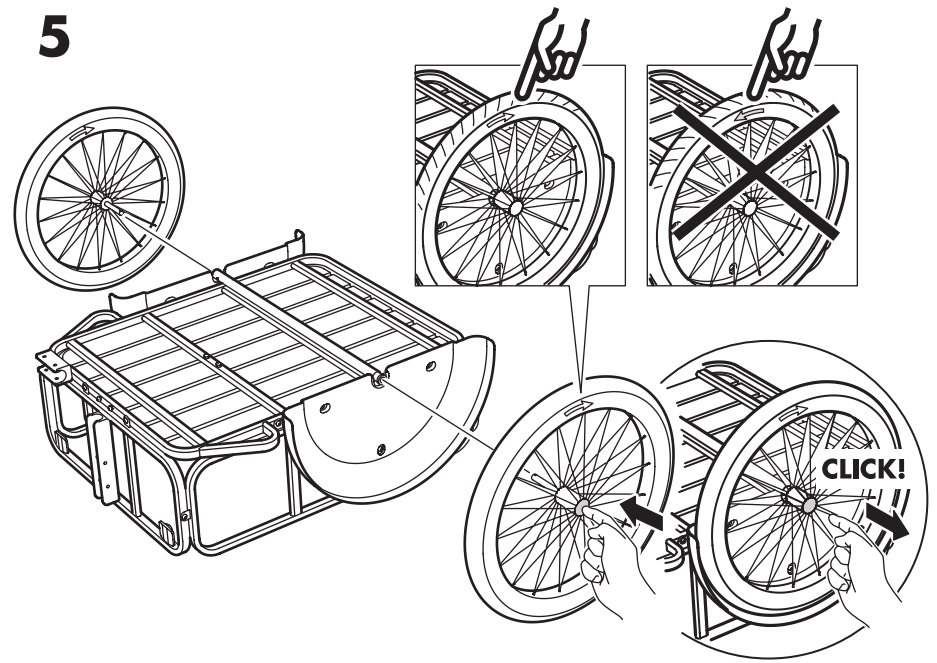
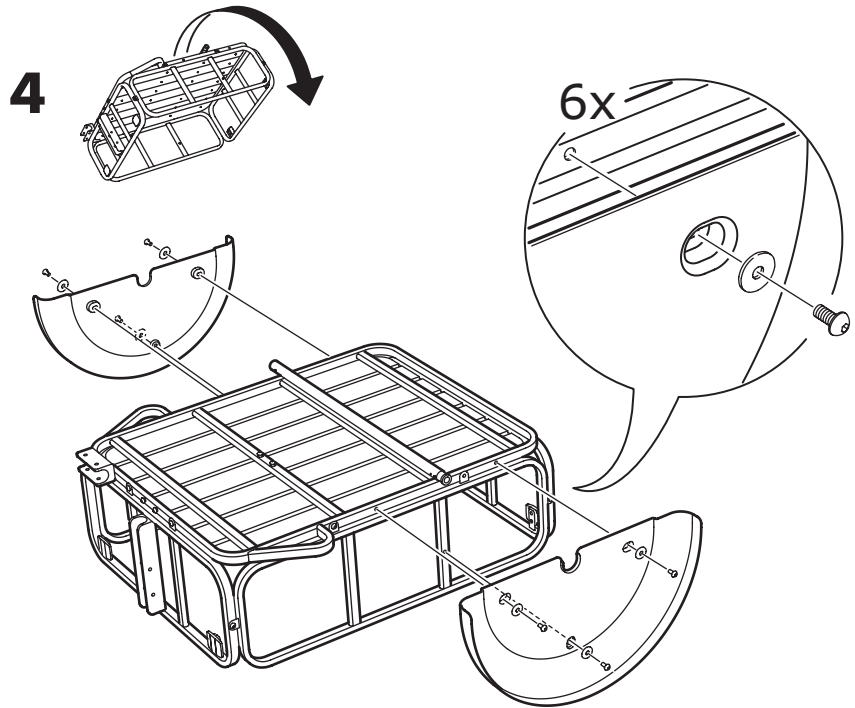
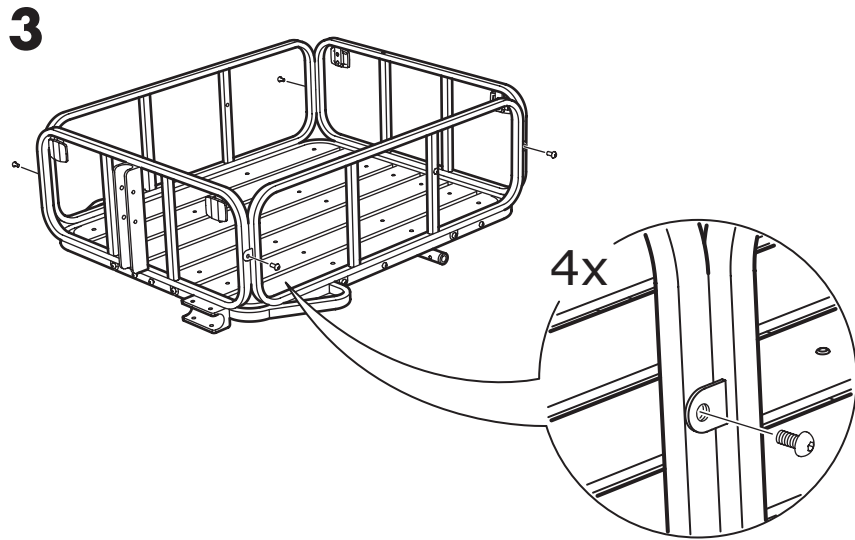

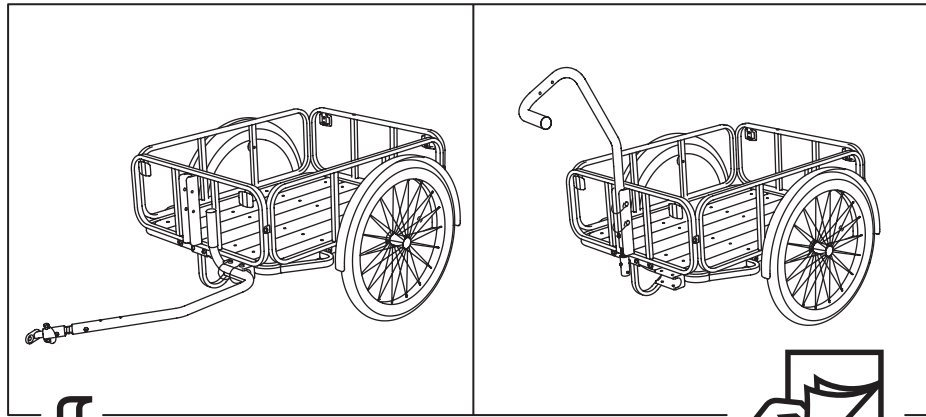

7

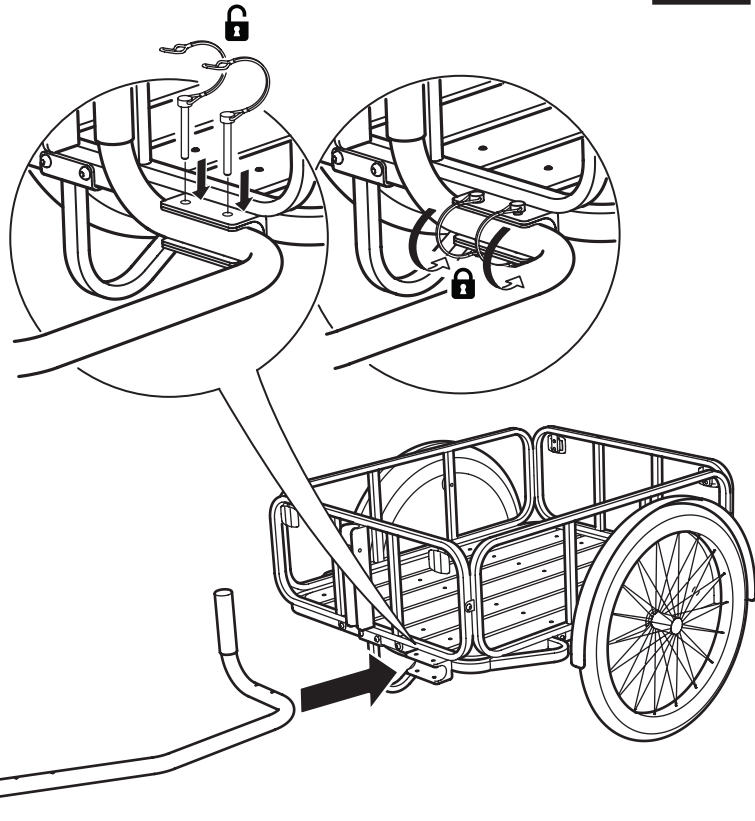

8

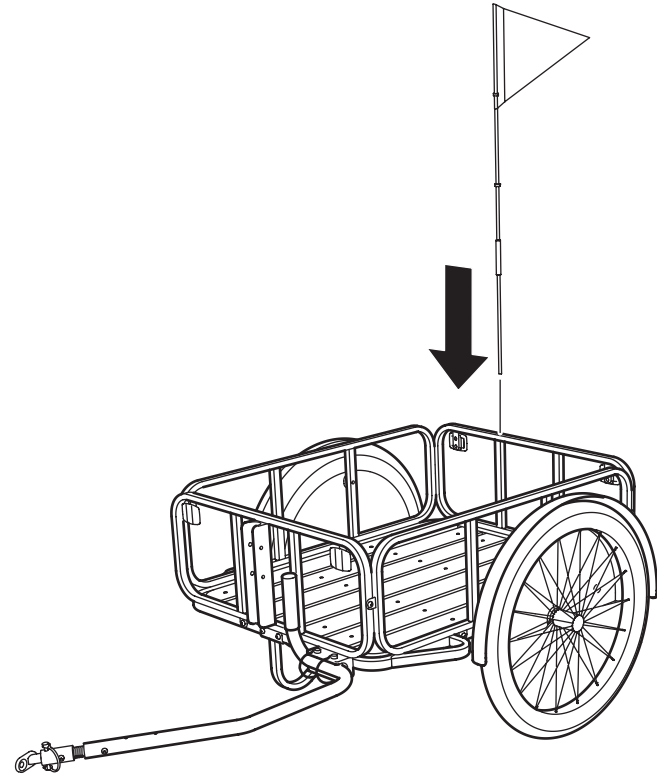

9

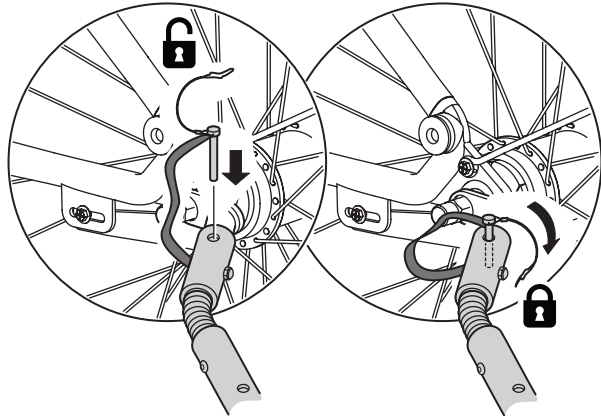
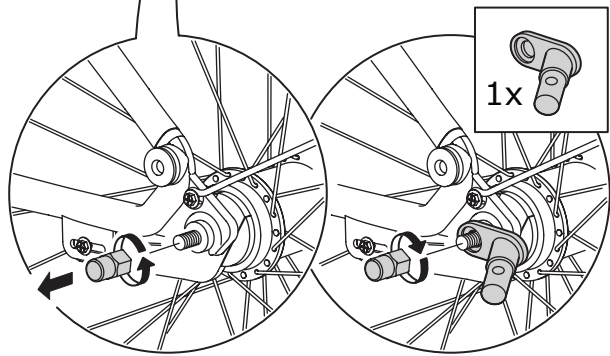
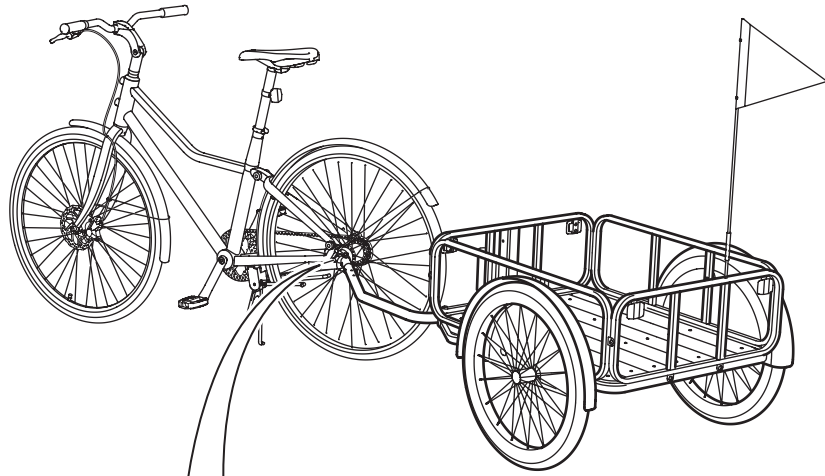

10

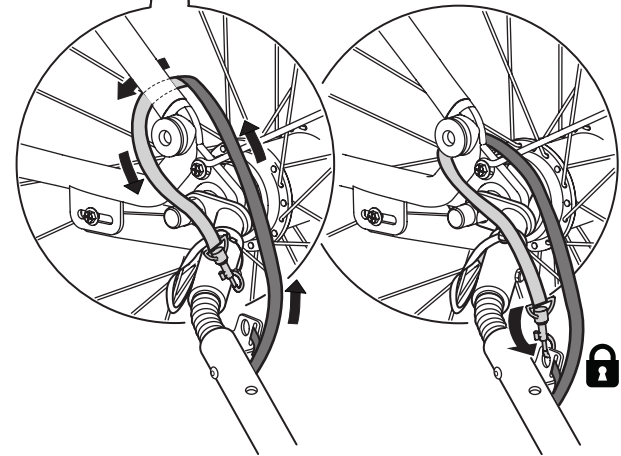
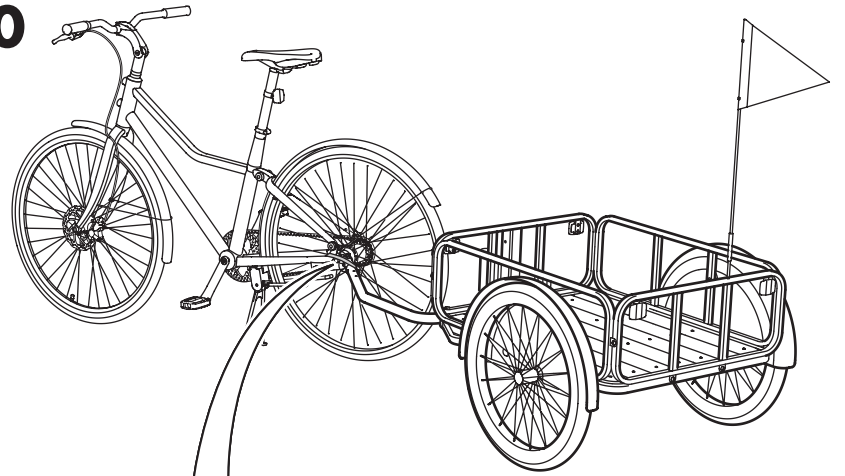

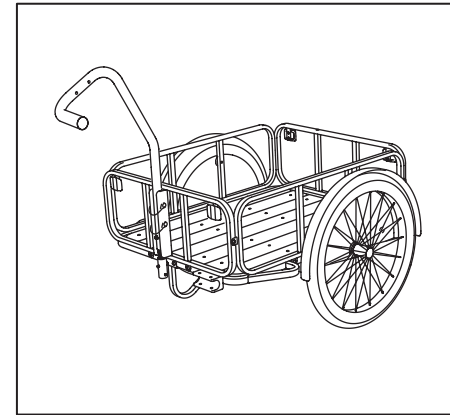
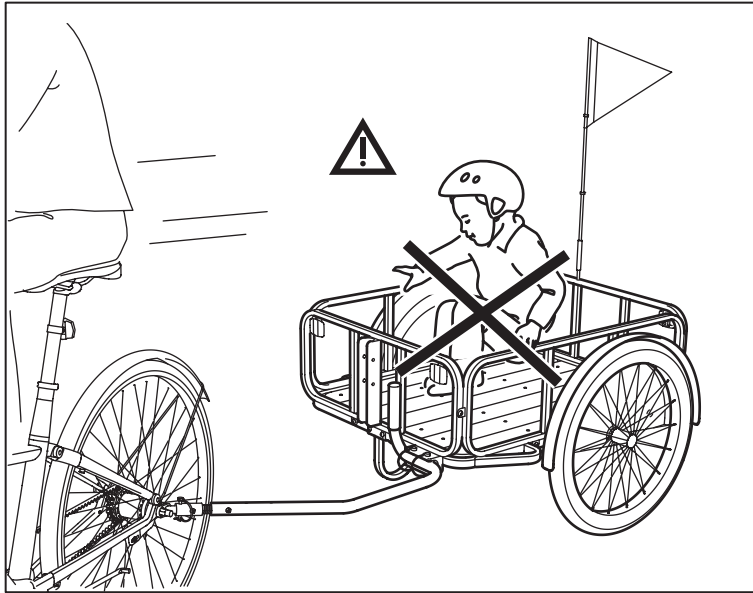

7

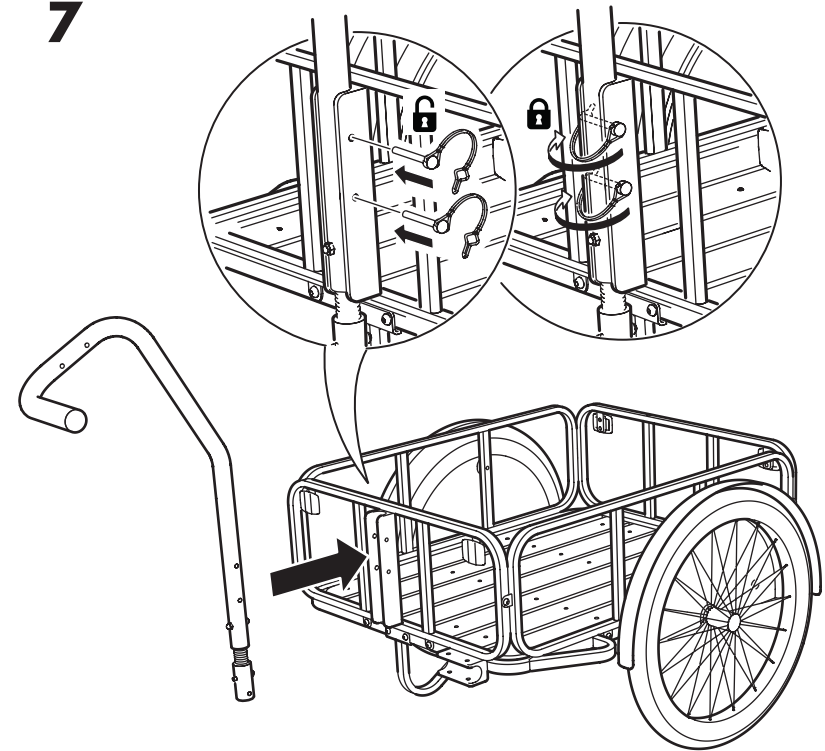

8

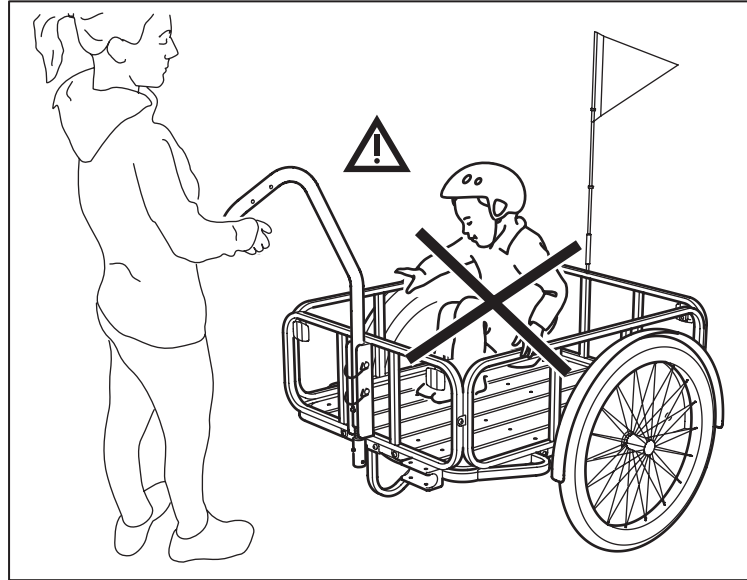
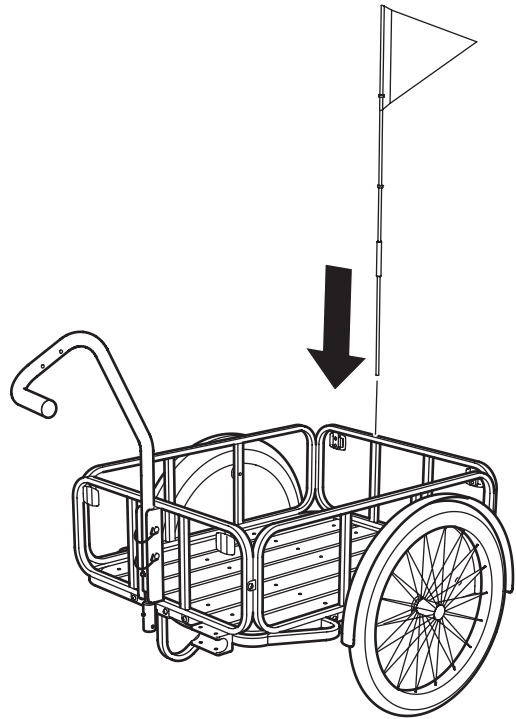

6. ΕΛΕΓΧΟΣ ΠΡΙΝ ΑΠΟ ΤΗ ΧΡΗΣΗ ΤΟΥ ΤΡΕΙΛΕΡ

Προτού χρησιμοποιήσετε το τρέιλερ σας θα πρέπει να κάνετε έναν έλεγχο ασφαλείας σε επίπεδο έδαφος και μακριά από έντονη κυκλοφορία. Είναι σημαντικό να βεβαιωθείτε ότι όλα τα εξαρτήματα είναι καλά στερεωμένα και λειτουργούν κανονικά.

ΕΛΕΓΞΤΕ ΤΑ ΛΑΣΤΙΧΑ

Βεβαιωθείτε ότι τα ελαστικά είναι φουσκωμένα στο συνιστώμενο όριο πίεσης χρησιμοποιώντας μια τρόμπα με μανόμετρο. Η πίεση δεν πρέπει να υπερβαίνει το συνιστώμενο όριο, όπως αναφέρεται στο λάστιχο. Είναι καλύτερα να χρησιμοποιήσετε μία τρόμπα χειρός ή ποδιού από μια αντλία πρατηρίου καυσίμων καθώς το υπερβολικό φούσκωμα μπορεί να κάνει το λάστιχο να σκάσει.

ΕΛΕΓΞΤΕ ΤΟΥΣ ΑΝΑΚΛΑΣΤΗΡΕΣ

Βεβαιωθείτε ότι οι ανακλαστήρες έχουν τοποθετηθεί σωστά.



ΠΡΟΕΙΔΟΠΟΙΗΣΗ! Όπως συμβαίνει με όλα τα μηχανικά μέρη, το τρέιλερ υπόκειται σε φθορά και υψηλή πίεση. Τα διάφορα υλικά και μέρη μπορεί να αντιδράσουν στη φθορά ή καταπόνηση με διαφορετικούς τρόπους. Αν έχει παρέλθει η διάρκεια ζωής ενός εξαρτήματος, μπορεί ξαφνικά να μη λειτουργήσει σωστά, πιθανώς προκαλώντας τραυματισμούς στον αναβάτη. Οποιασδήποτε μορφής ρωγμές, γρατζουνιές ή αλλαγή του χρωματισμού σε σημεία έντονης καταπόνησης δείχνουν ότι έχει ολοκληρωθεί η διάρκεια ζωής του εξαρτήματος και θα πρέπει να αντικατασταθεί.

