

SOLARVET

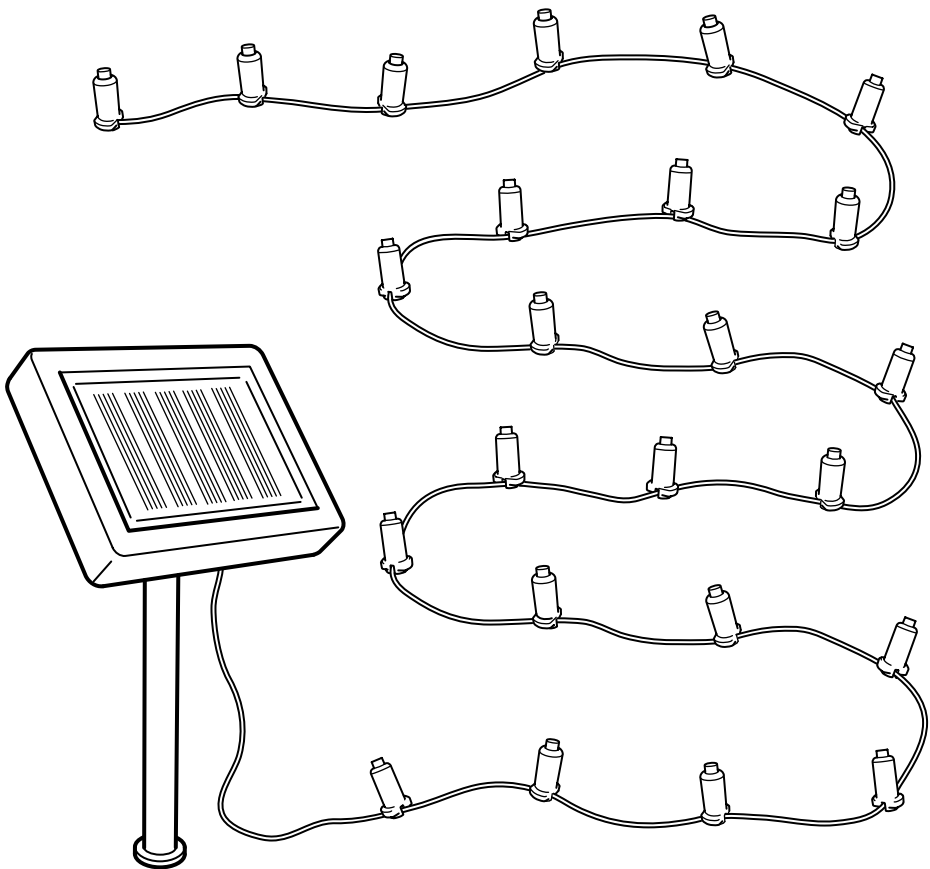

Design and Quality
IKEA of Sweden

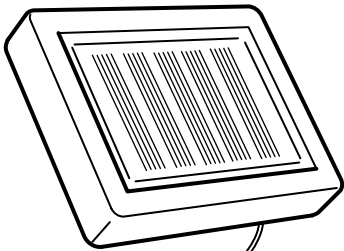
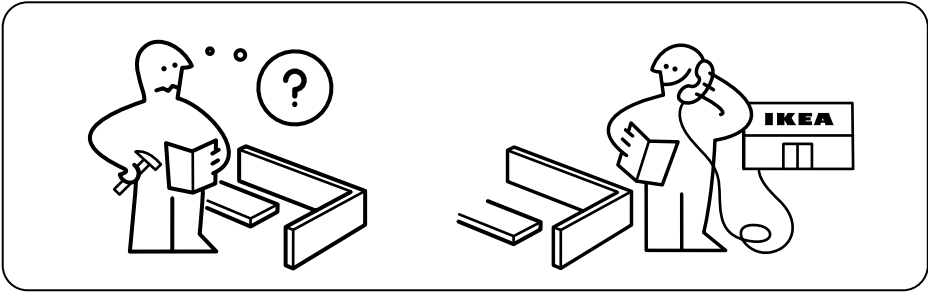

1x

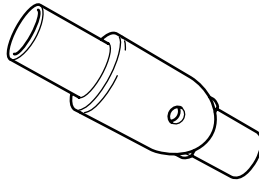

1x

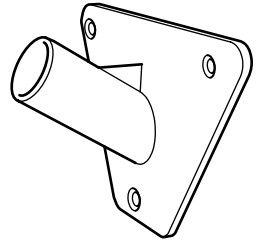

1x

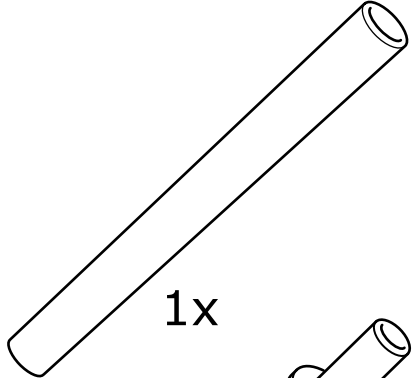
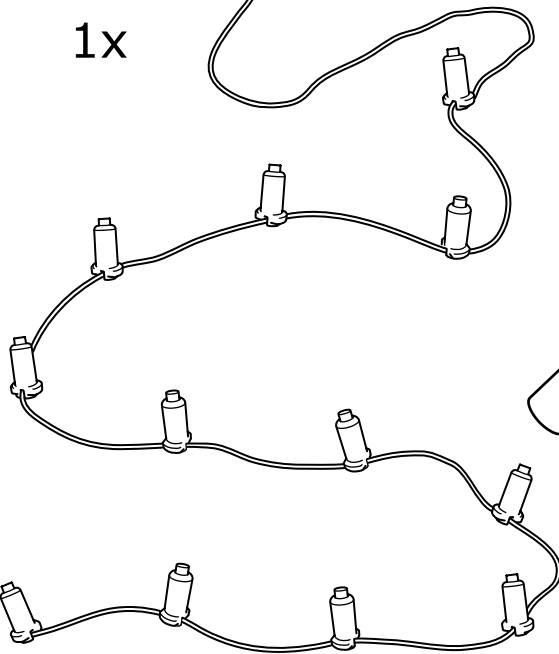

1x

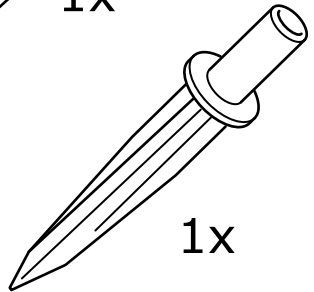

1x

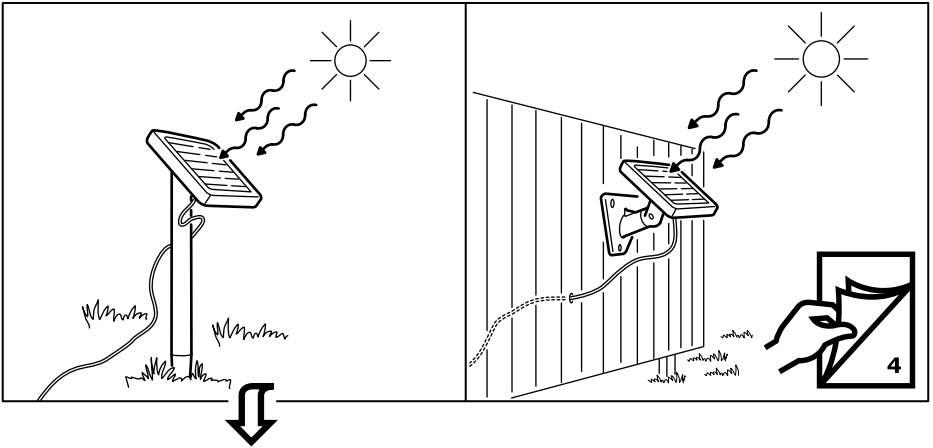

1

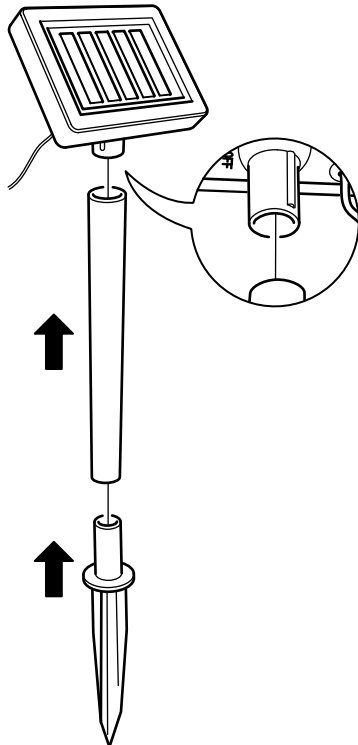

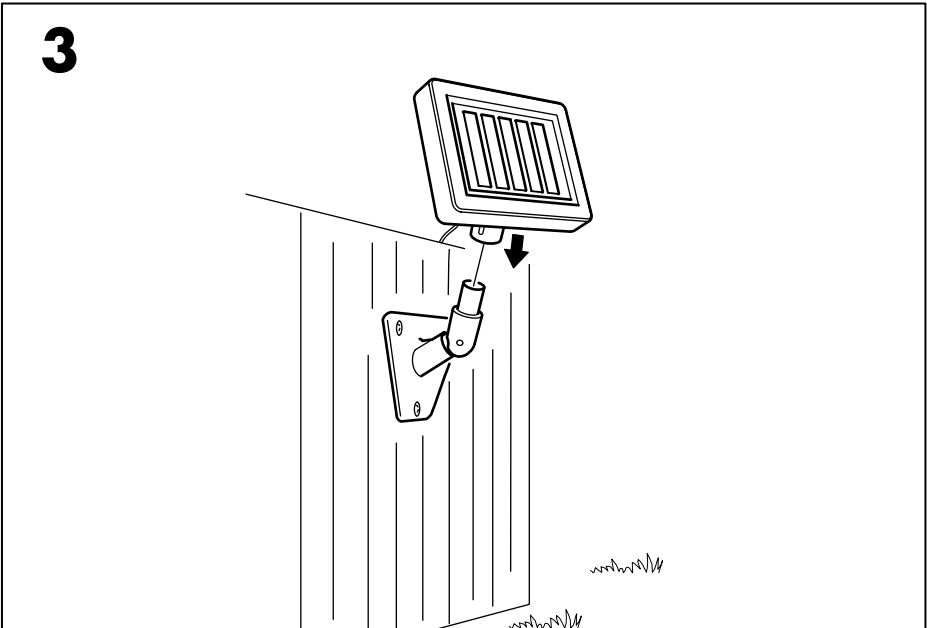
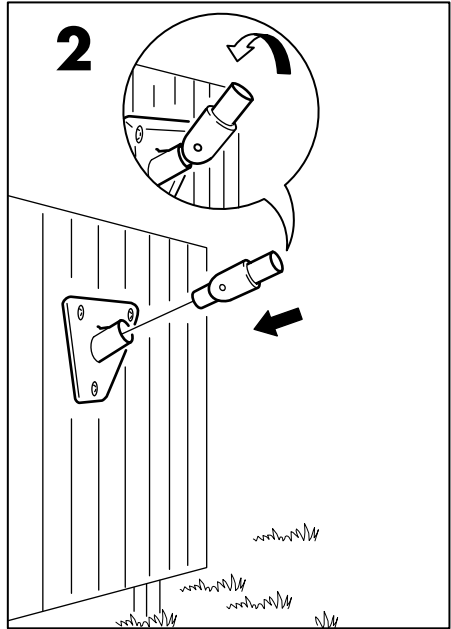
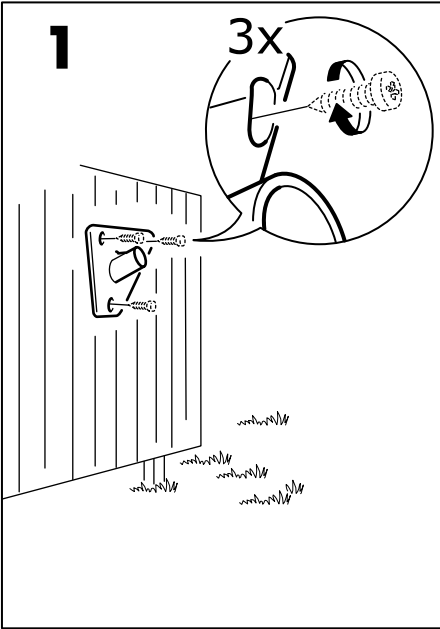

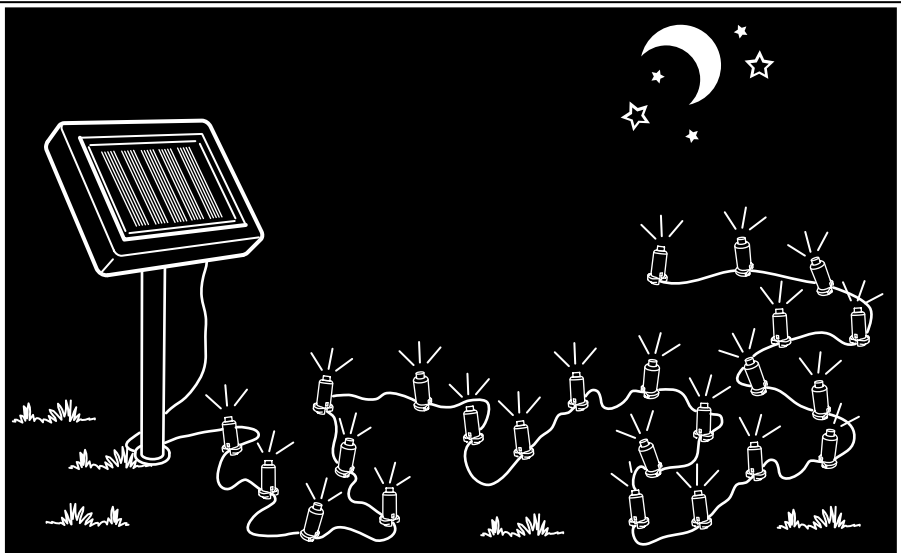
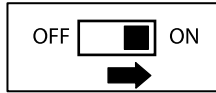
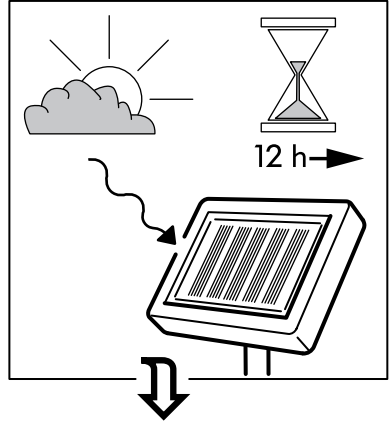
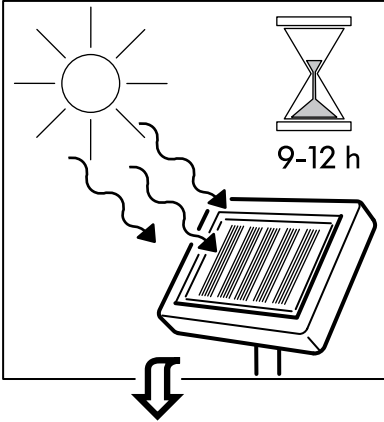

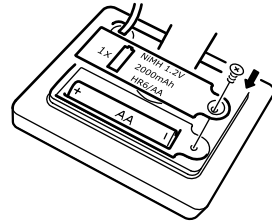
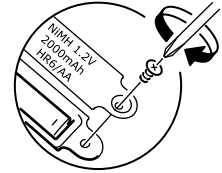
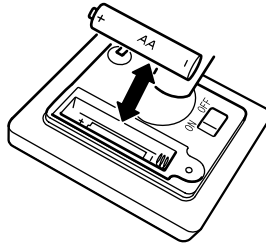
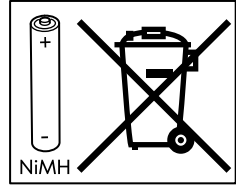
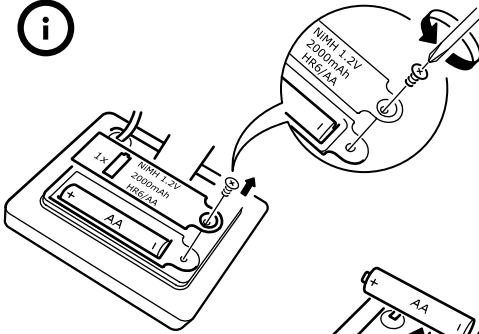

ENGLISH

After approximately 2 years, the rechargeable batteries need to be replaced when the lamp don't light up. Replace with Ni-MH rechargeable 1.2V, 2000mAH, AA type batteries.

Light Source is LED (Light Emitting Diodes), the LED can not be exchanged by customer.

SAVE THESE INSTRUCTIONS FOR FUTURE USE.

DEUTSCH

Wenn die Leuchte nicht mehr brennt, muss der Akku nach ca. 2 Jahren ausgewechselt werden. Den alten Akku mit einem neuen vom Typ Ni-MH 1,2V, 2000mAh, AA ersetzen.

Die Lichtquelle dieses Produkts besteht aus Leuchtdioden (LED), die vom Kunden nicht ausgetauscht werden können.

DIESE INFORMATION FÜR SPÄTER AUFBEWAHREN.

FRANÇAIS

Remplacer les piles rechargeables au bout de 2 ans environ, lorsque la lampe n'éclaire plus. Remplacer par des piles rechargeables Ni-MH, 1,2V, 2000mAh, AA.

La source lumineuse de ce produit est composée d'une LED (Diode électroluminescente), qui ne peut être changée par le client.

CONSERVER CES INSTRUCTIONS POUR UNE UTILISATION ULTÉRIEURE.

NEDERLANDS

Na ongeveer 2 jaar, als de lamp niet meer aangaat, moeten de oplaadbare batterijen worden vervangen. Vervang de oude door nieuwe oplaadbare batterijen van het type Ni-MH 1,2V, 2000mAh, AA.

De lichtbron is led. Led-verlichting kan niet door de klant worden vervangen.

BEWAAR DEZE INSTRUCTIES VOOR TOEKOMSTIG GEBRUIK.

DANSK

Efter ca. 2 år skal de genopladelige batterier udskiftes, hvis lampen ikke lyser. Udskift med Ni-MH genopladelige 1,2V, 2000 mAh, AA-batterier.

Lyskilden er en LED pære, som ikke kan udskiftes af kunden.

GEM DISSE ANVISNINGER TIL SENERE BRUG.

ÍSLENSKA

Eftir u.þ.b. tvö ár, þegar ekki kviknar lengur á ljósinu, þarf að skipta hleðslurafhlöðunum út. Notið Ni-MH 1.2 V, 2000mAh, AA hleðslurafhlöður. Ljósíð er búið LED þerum (ljósdíóðum), sem ekki er hægt að skipta um.

GEYMIÐ ÞESSAR LEIÐBEININGAR.

NORSK

Etter rundt 2 år må de oppladbare batteriene erstattes når lampa slutter å lyse. Erstatt dem med oppladbare batterier av typen NiMH 1,2 V, 2000 mAh, AA. Lyskilden er LED (lysdioder), og kan ikke skiftes ut av kunden.

TA VARE PÅ DISSE INSTRUKSJONENE FOR FREMTIDIG BRUK.

SUOMI

Noin 2 vuoden käytön jälkeen akut on vaihdettava, jos lamppu ei syty. Vaihdoakujen on oltava ladattavia 1,2 V:n Ni-MH-akkuja (2000 mAh, AA). Valonlähde on led-lamppu, jota ei voi vaihtaa itse.

SÄÄSTÄ NÄMÄ OHJEET VASTAISUUDEN VARALLE.

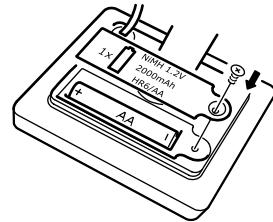
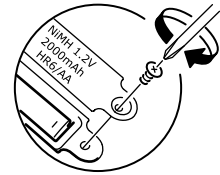
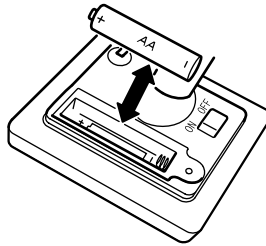
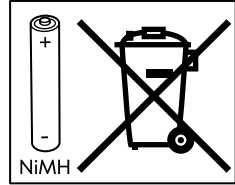
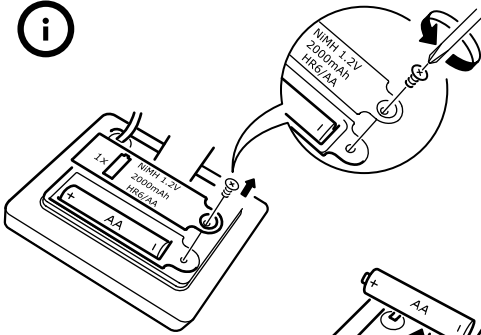

SVENSKA

Efter ungefär 2 år behöver det laddningsbara batteriet bytas ut när lampan inte längre tänds. Ersätt med laddningsbara batterier av typen Ni-MH 1,2V, 2000mAh, AA.

Ljuskällan är LED. LED-belysning kan inte bytas ut av kunden.

SPARA DESSA INSTRUKTIONER FÖR FRAMTIDA BRUK.

ČESKY

Jakmile přibližně po 2 letech nepůjde lampu rozsvítit, je potřeba vyměnit dobíjecí baterie. Vyměňte je za baterie typu NI-MH 1,2 V, 2000 mAh, AA.

Zdrojem světla je žárovka LED (Light Emitting Diodes), kterou nemůže sám zákazník vyměnit.

TYTO INSTRUKCE SI USCHOVEJTE PRO POZDĚJŠÍ POUŽITÍ.

ESPAÑOL

Reemplaza las pilas recargables después de unos 2 años, cuando la lámpara no se enciende. Reemplázalas por pilas recargables Ni-MH, 1,2V, 2000mAH, AA.

La fuente luminosa de este producto es un LED, que el cliente no puede cambiar. GUARDA ESTAS INSTRUCCIONES PARA UN USO POSTERIOR.

ITALIANO

Dopo circa 2 anni, quando la lampada non si accende, è necessario cambiare le batterie ricaricabili. Sostituiscile con batterie ricaricabili Ni-MH 1,2V, 2000mAH, AA.

La fonte luminosa di questo prodotto è costituita da LED (Light Emitting Diodes), non sostituibili dal cliente.

CONSERVA QUESTE ISTRUZIONI PER ULTERIORI CONSULTAZIONI.

MAGYAR

Nagyjából 2 év után az újratölthető elemeket cserélni kell, ha a lámpa bekapcsoláskor nem akar meggyulladni. Cseréld ki új, Ni-MH újratölthető, 1,2 V, 2000mAH, AA típusú elemekre. A lámpa fényforrása LED, melyet nem lehet cserélni.

ŐRIZD MEG EZT AZ INFORMÁCIÓT A JÖVŐBEN IS!

POLSKI

Po około 2 latach akumulatory należy wymienić, jeżeli lampka się nie świeci. Wymień na akumulatory Ni-MH 1,2 V, 2000mAH, typ AA.

Źródłem światła jest dioda LED (Light Emitting Diodes), która nie może być wymieniona przez klienta.

ZACHOWAJ NINIEJSZĄ INSTRUKCJĘ DO WYKORZYSTANIA W PRZYSZŁOŚCI.

EESTI

Umbes peale 2-aastast kasutamist tuleks taaslaetavad patareid väljavahetada kui valgusti ei tööta. Asenda Ni-MH taaslaetavate patareidega tüüp 1,2V, 2000mAH, AAA.

Valguseallikas on LED, seda ei saa vahetada klient.

HOIA SEE JUHEND ALLES.

LATVIEŠU

Pēc aptuveni 2 gadiem, ja lampa vairs nedeg, lādējamās baterijas nepieciešams nomainīt. Nomainiet tās ar 1,2V, 2000mAH, AA tipa Ni-MH lādējamām baterijām.

LED spuldžu nomaigu nedrīkst veikt patstāvīgi!

SAGLABĀJIET ŠO INSTRUKCIJU TURPMĀKAI UZZIŅAI.

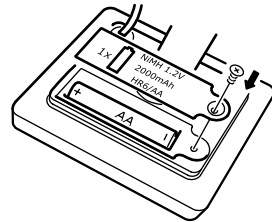
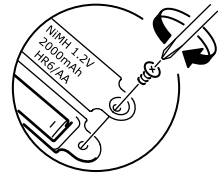
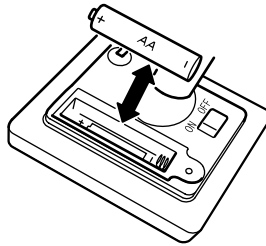
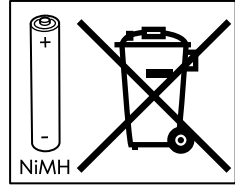
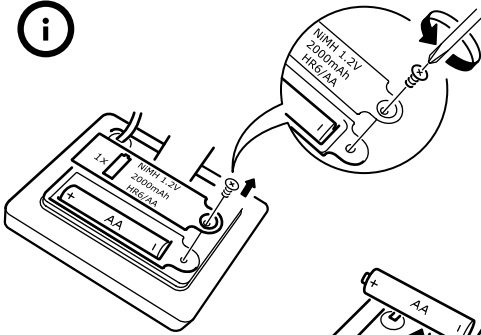

LIETUVIŲ

Maždaug po 2 metų, jei lempa neužsidega, reikia keisti įkraunamas baterijas. Pakeiskite jas įkraunamomis Ni-MH, 1,2 V, 2000 mAh, AA tipo baterijomis. Šviesos šaltinis yra šviesos diodas (LED). Nekeiskite jo patys!

SAUGOKITE ŠIAS INSTRUKCIJAS.

PORTUGUÊS

Após cerca de 2 anos, as pilhas recarregáveis precisam de ser substituídas quando a lâmpada deixa de acender. Substitua por pilhas de tipo AA recarregáveis Ni-MH de 1,2V, 2000mAh. A fonte de iluminação é LED (Díodos Emissores de Luz), o LED não pode ser trocado pelo cliente.

GUARDE ESTAS INSTRUÇÕES PARA CONSULTA POSTERIOR.

ROMÂNĂ

După aproximativ 2 ani, bateriile reîncărcabile trebuie să fie schimbate. Înlocuieste-le cu baterii reîncărcabile Ni-MH 1.2V, 2000mAh, AA.

Becul este LED, iar acesta nu poate fi schimbat de către cumpărător.

PĂSTREAZĂ ACESTE INSTRUCȚIUNI.

SLOVENSKY

Akonáhle sa lampa približne po 2 rokoch nebude dať rozsvietiť, je potrebné vymeniť dobíjacie batérie. Vymeňte ich za batérie typu NI-MH 1,2 V, 2000 mAh, AA. Zdrojom svetla je LED žiarovka (Light Emitting Diodes), ktorú si zákazník nemôže vymeniť sám.

TIETO INŠTRUKCIE SI USCHOVAJTE NA NESKORŠIE POUŽITIE.

БЪЛГАРСКИ

След около 2 години акумулаторните батерии трябва да бъдат подменени, когато лампата не светва. Подменете ги с Ni-MH акумулаторни 1.2V, 2000mAh батерии тип AA.

Светлинният източник е LED (светодиоди) - светодиодите не могат да се подменят от клиента.

ЗАПАЗЕТЕ ТЕЗИ ИНСТРУКЦИИ ЗА БЪДЕЩА СПРАВКА.

HRVATSKI

Nakon otprilike 2 godine, kad se lampa više ne pali, punjive je baterije potrebno zamijeniti. Zamijenite Ni-MH punjivim 1,2 V, 2000 mAh, AA baterijama.

Izvor svjetlosti su LED žarulje koje ne može zamijeniti kupac.

SAČUVAJTE OVE UPUTE ZA BUDUĆE POTREBE.

ΕΛΛΗΝΙΚΑ

Μετά από περίπου 2 χρόνια, οι επαναφορτιζόμενες μπαταρίες πρέπει να αντικατασταθούν, όταν το φωτιστικό δεν ανάβει. Αντικαταστήστε με επαναφορτιζόμενες Ni-MH, 1.2V, 2000mAh, τύπου AA μπαταρίες. Η πηγή φωτός είναι LED (Light Emitting Diodes) και δεν μπορεί να αντικατασταθεί από τον πελάτη.

ΚΡΑΤΗΣΤΕ ΑΥΤΕΣ ΤΙΣ ΟΔΗΓΙΕΣ ΓΙΑ ΜΕΛΛΟΝΤΙΚΗ ΧΡΗΣΗ.

РУССКИЙ

Приблизительно после 2 лет использования перезаряжаемые батарейки необходимо заменить, если светильник не работает. Используйте перезаряжаемые батарейки Ni-MH 1,2 В, 2000 мА/час, AA.

Потребитель не может самостоятельно заменить источник света – светодиод.

СОХРАНИТЕ ЭТУ ИНФОРМАЦИЮ ДЛЯ ДАЛЬНЕЙШЕГО ИСПОЛЬЗОВАНИЯ.

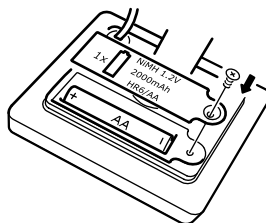
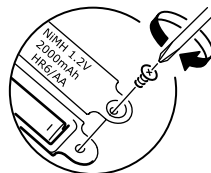
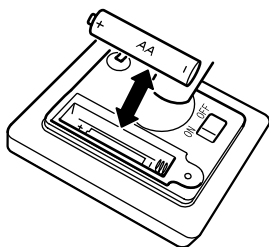
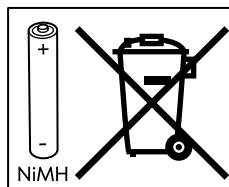
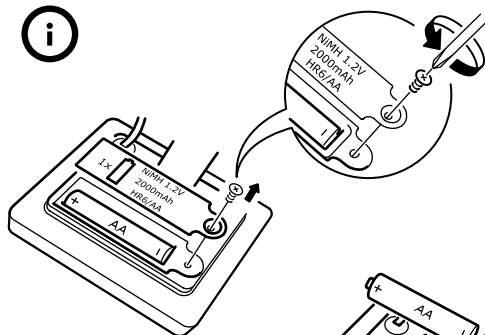

SRPSKI

Nakon oko 2 godine, ako lampa više neće da se uključi, treba da zamenite punjive baterije. Zamenite ih Ni-MH punjivim 1.2V, 2000mAh, AA tipom baterija.

Izvor svetlosti je LED (diode koje emituju svetlost), a njega kupac sam ne može da zameni.

SAČUVAJTE OVO UPUTSTVO ZA UBUĐUĆE.

SLOVENŠČINA

Polnilne baterije je treba zamenjati po približno 2 letih, ko se svetilka ne prižge več. Nadomestite jih s polnilnimi Ni-MH baterijami, 1,2 V, 2000 mAh, tipa AA. Vir svetlobe so LED svetilne diode, ki jih ni mogoče zamenjati.

SHRANITE TA NAVODILA ZA NADALJNJO UPORABO.

TÜRKÇE

Yaklaşık 2 yıl sonra, lamba aydınlatmadığında şarj edilebilir pillerin değiştirilmesi gerekir. Ni-MH şarj edilebilir 1.2V, 2000mAh, AA tipi pillerle değiştiriniz. LED ampul (Işık Yayan Diyotlar), müşteri tarafından değiştirilemez.

İLERDE GEREKEBİLECEĞİ İÇİN BU TALİMATLARI SAKLAYINIZ.

中文

使用两年左右，若台灯无法点亮则需要更换充电电池，请换上 1.2V, 2000mAh, AA 充电电池。

光源为 LED(发光二极管)，使用者不得自行更换 LED 光源。

保存说明，作为使用参考。

繁中

使用約2年後·燈具不亮時需更換充電電池。請更換3號鎳氫充電電池(1.2V, 2000mAh)。

產品使用不需更換的LED燈泡。

請妥善保存說明書·以供參考。

한국어

약 2년 뒤 램프에 불이 들어오지 않으면 충전지를 교체해야 합니다. Ni-MH 충전지 1.2V, 2000mAh, AA 타입으로 교체하세요.

광원은 LED(Light Emitting Diodes)이며, LED는 직접 교체하실 수 없습니다.

후일 참고를 위해 이 유의사항을 보관해 주세요.

日本語

電気がつかなくなった場合は、充電用電池を交換する必要があります(交換時期の目安は、ご使用後約2年です)。充電には、ニッケル水素充電電池(1.2V/2000mAh/AA)をお使いください。

本製品の光源にはLEDを使用しています。LEDは交換できません。

この説明書は、いつでも参照できるように大切に保管してください。

BAHASA INDONESIA

Setelah sekitar 2 tahun, baterai isi ulang perlu diganti saat lampu tidak menyala.

Ganti dengan baterai isi ulang tipe Ni-MH 1.2V, 2000mAh, AA.

Sumber Cahaya adalah LED (Dioda Pemancar Cahaya), LED tidak dapat ditukar oleh pelanggan.

SIMPAN PETUNJUK INI UNTUK PENGGUNAAN MASA DATANG.

BAHASA MALAYSIA

Apabila lampu tidak menyala selepas lebih kurang 2 tahun, bateri yang telah dicas semula perlu diganti. Gantikan dengan bateri AA, 1.2V, 2000mAh yang boleh dicas semula.

Sumber cahaya ialah LED (Diod Pancaran Cahaya), pelanggan tidak boleh menukar ganti LED.

SIMPAN ARAHAN INI UNTUK KEGUNAAN AKAN DATANG.

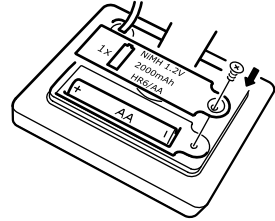
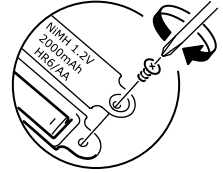
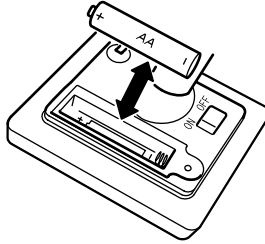
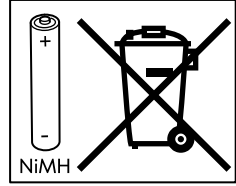
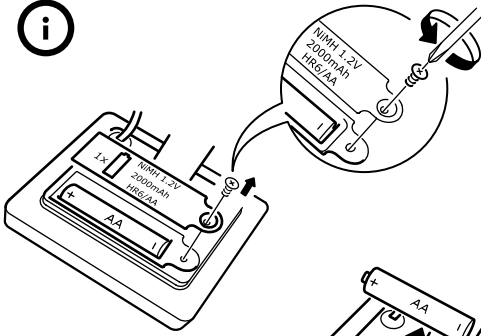

عربي

بعد سنتين تقريباً، تحتاج البطاريات القابلة للشحن إلى استبدال عندما لا تضيء الللمبة. استبدلي بطاريات قابلة للشحن من النوعية Ni-MH 1.2V، 2000mAh، AA. مصدر الضوء LED ويعني) الدايودات الباعثة للضوء(، لمبات LED لا يمكن للعمل أن يستبدلها.

يرجى حفظ هذه التعليمات لاستخدامها في المستقبل.

ไทย

ใช้แบตเตอรี่ชนิดชาร์จไฟได้ แบตเตอรี่มีอายุใช้งานประมาณ ๒ ปี เมื่อครบกำหนดเวลาดังกล่าว หากโคมไฟเปิดไม่ติด ให้เปลี่ยนแบตเตอรี่ (ใช้แบตเตอรี่ AA แบบชาร์จไฟได้ Ni-MH ๑.๒V ๒๐๐๐mAh) โคมไฟใช้หลอด LED ห้ามผู้ใช้เปลี่ยนหลอด LED เอง

เก็บคู่มือนี้ไว้ เพื่อใช้ในการเลือกซื้อแบตเตอรี่ได้อย่างถูกต้อง

