

TÄMNAREN

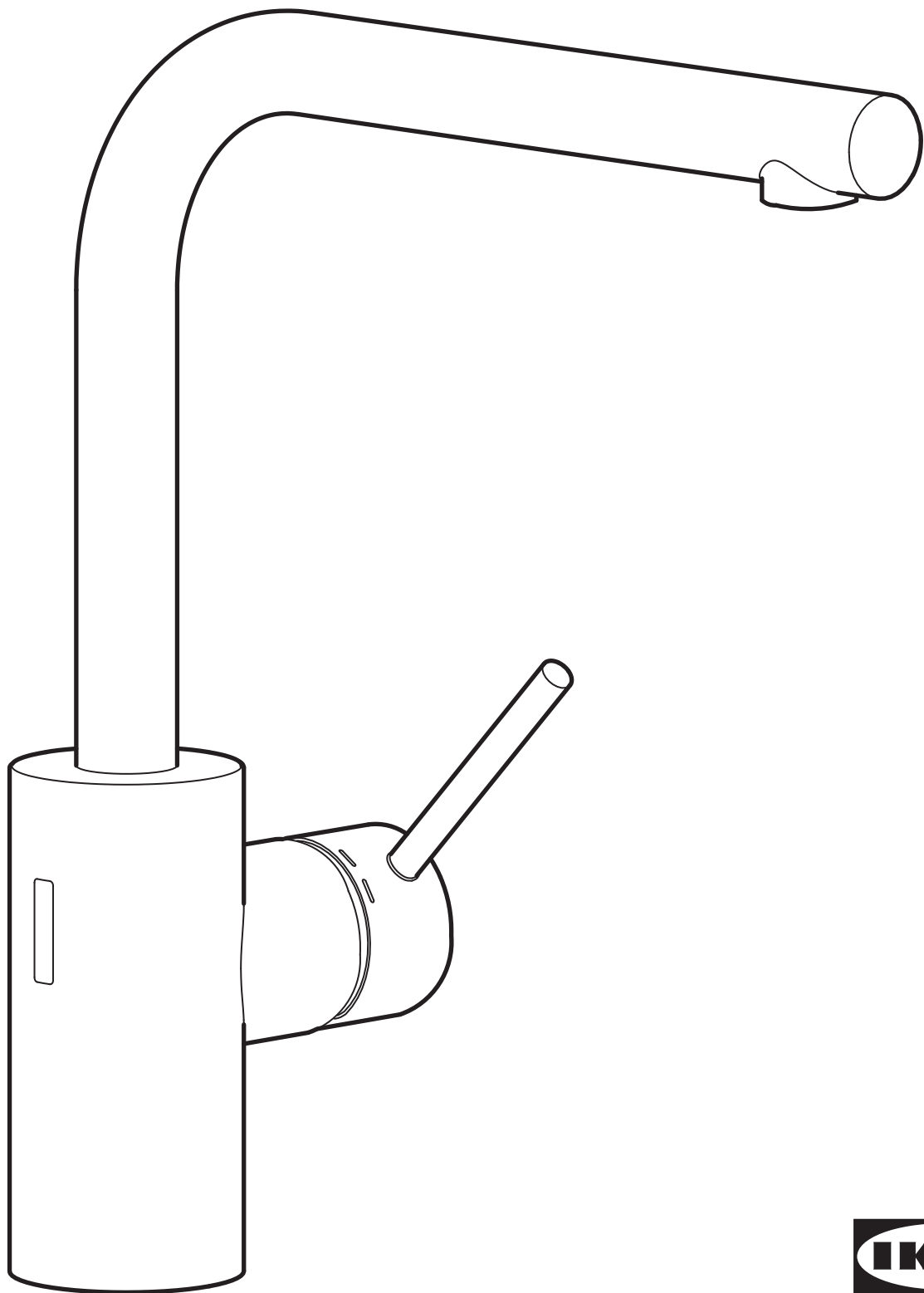

Design and Quality
IKEA of Sweden

**English**

Installation must be performed in compliance with current local construction and plumbing regulations. If in doubt, contact a professional.

Français

L'installation doit être réalisée en conformité avec les normes actuelles relatives à la construction et à la plomberie. En cas de doute, contacter un professionnel.

Español

La instalación debe realizarse siguiendo las normativas actuales sobre construcción y fontanería. En caso de duda, ponte en contacto con un profesional.

**English**

Switch off main shut-off valve before changing mixer tap.

Français

Fermer le robinet central d'eau avant de changer le mitigeur.

Español

Cierra la llave de paso general antes de cambiar el grifo.

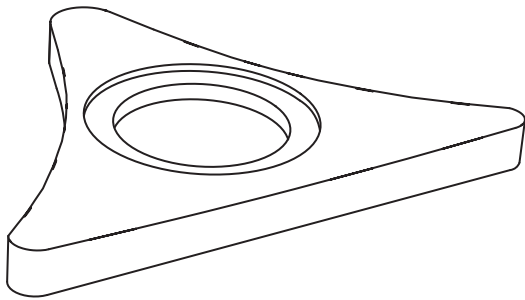
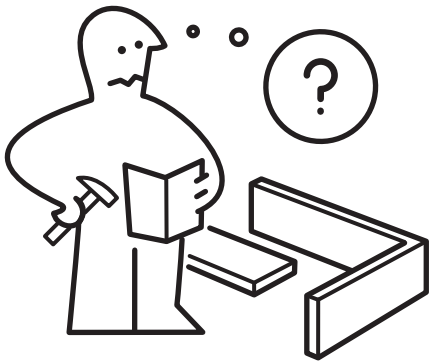
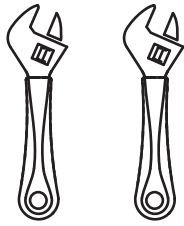

120087



120143

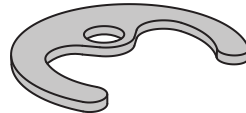

120142



120141

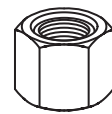

120172

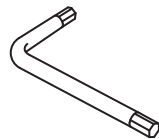

110084

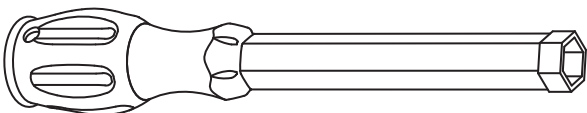

126908



10004086

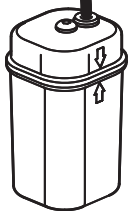
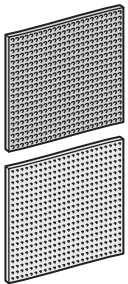
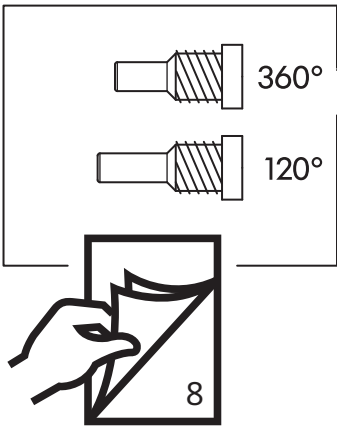
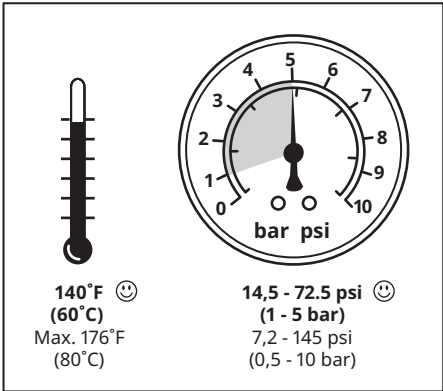
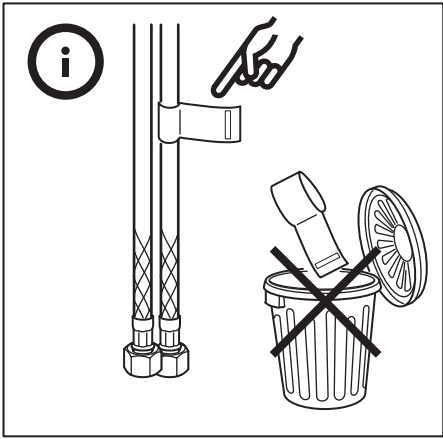

10004086

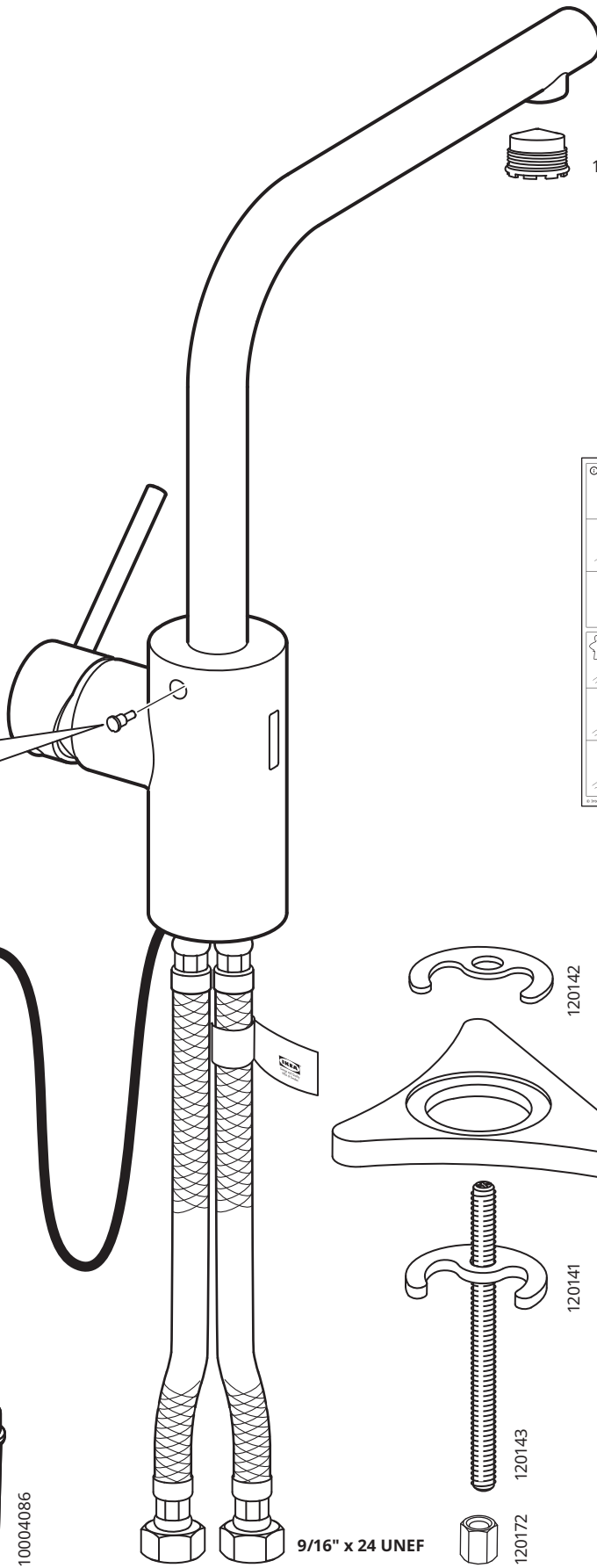

124607

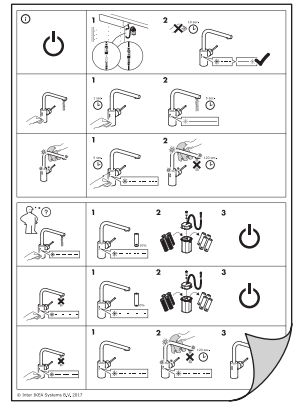

120142

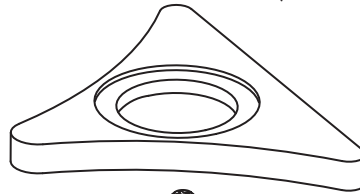

120087

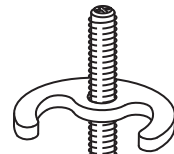

120141



120143



120172

9/16" x 24 UNEF

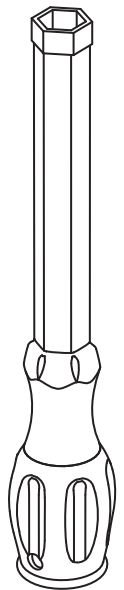

126908

1

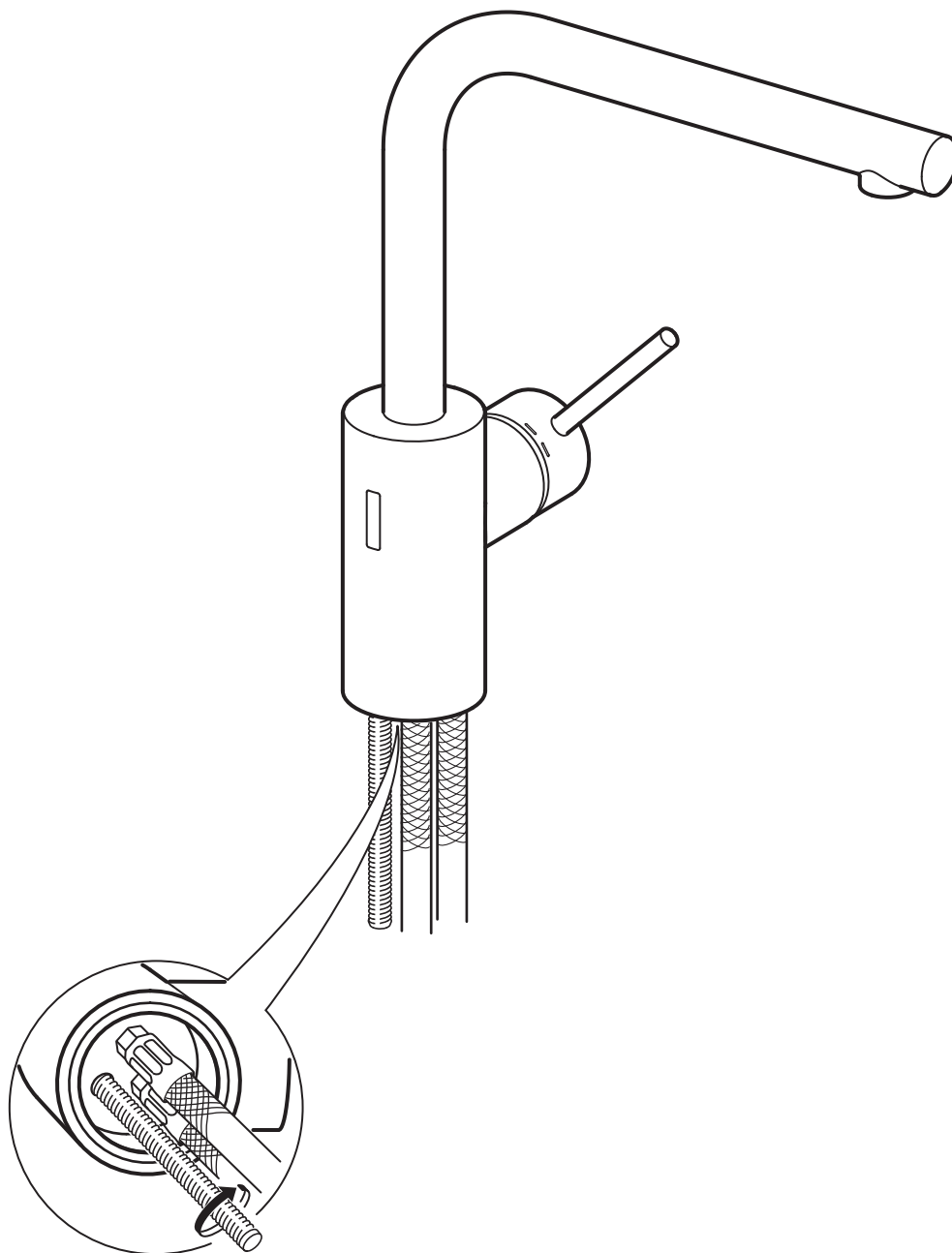

English

Seal the open surfaces with silicone to prevent water from penetrating the worktop upon any leaks. Silicone is not included.

Français

Appliquer un joint de silicone sur les interstices pour éviter les infiltrations d'eau dans le plan de travail en cas de fuite. Le silicone n'est pas inclus.

Español

Aplicar silicona en las juntas para evitar que penetren líquidos en la encimera en caso de fuga. La silicona no está incluida.

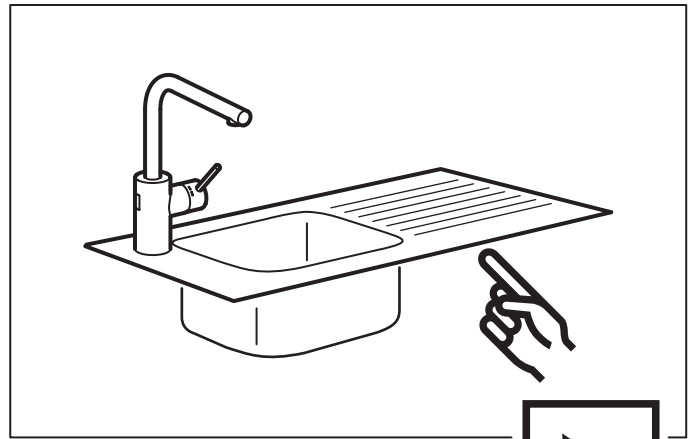
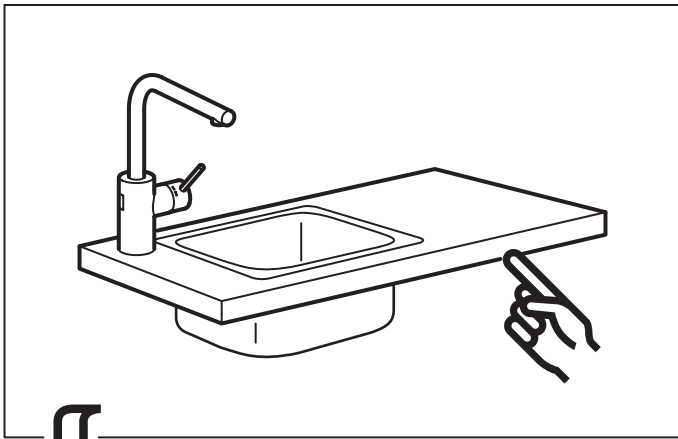

2

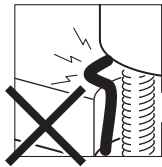
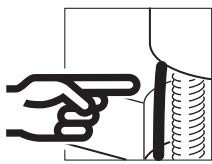

Max 50 mm
Max 2"

Ø 34 - 37 mm
Ø 1 3/8" - 1 1/2"

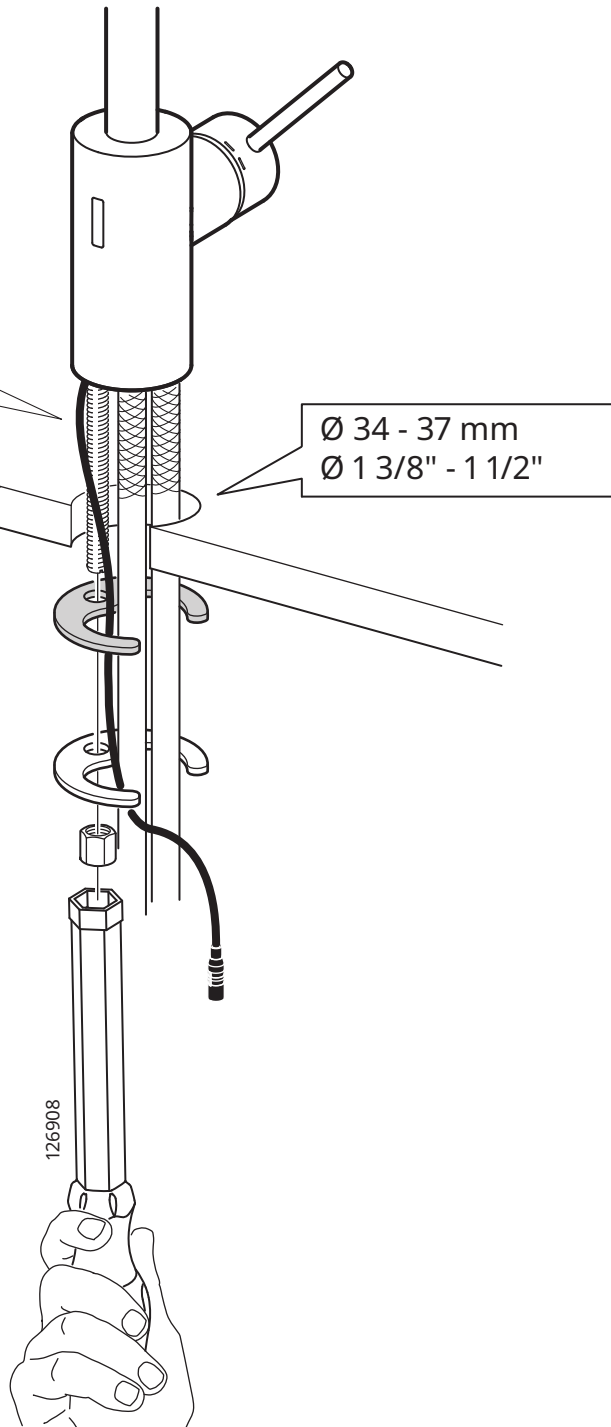

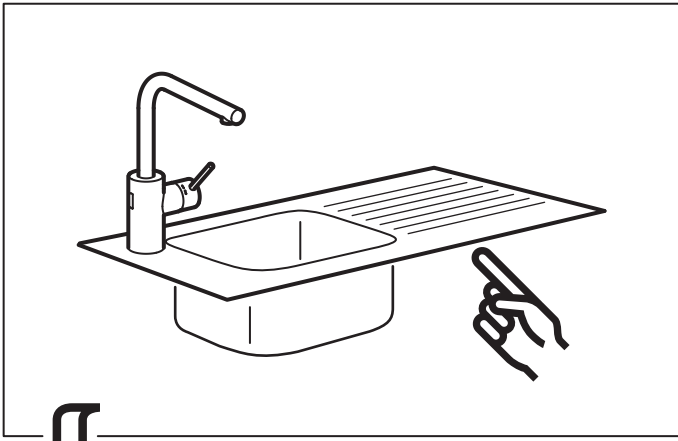

2

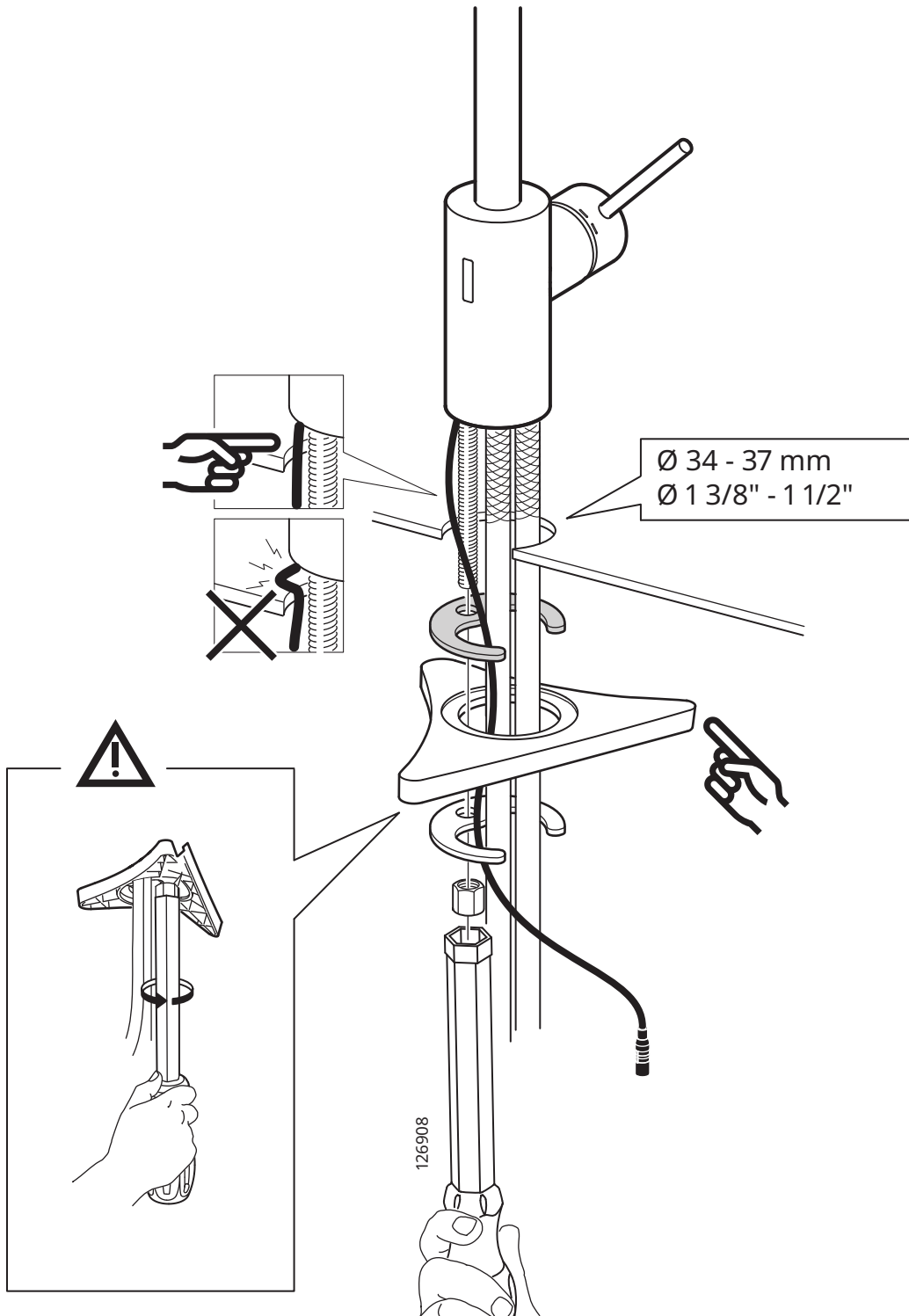

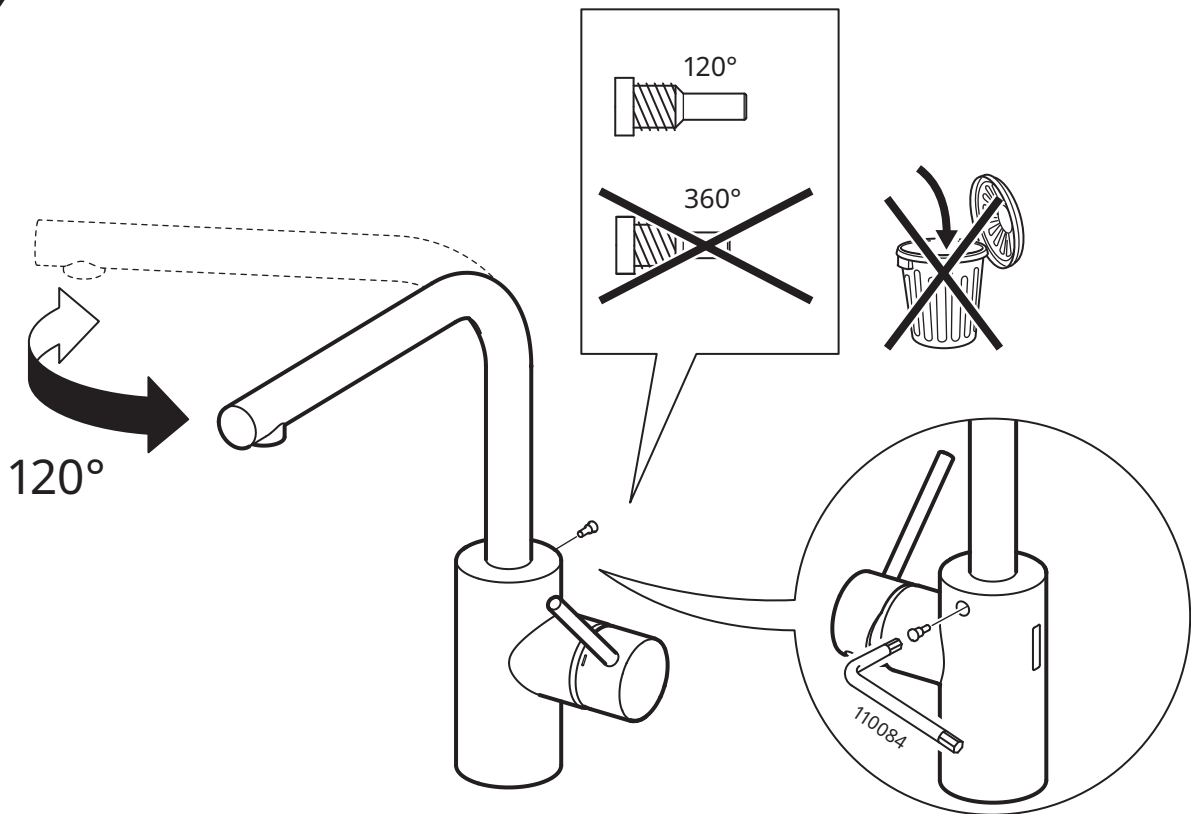
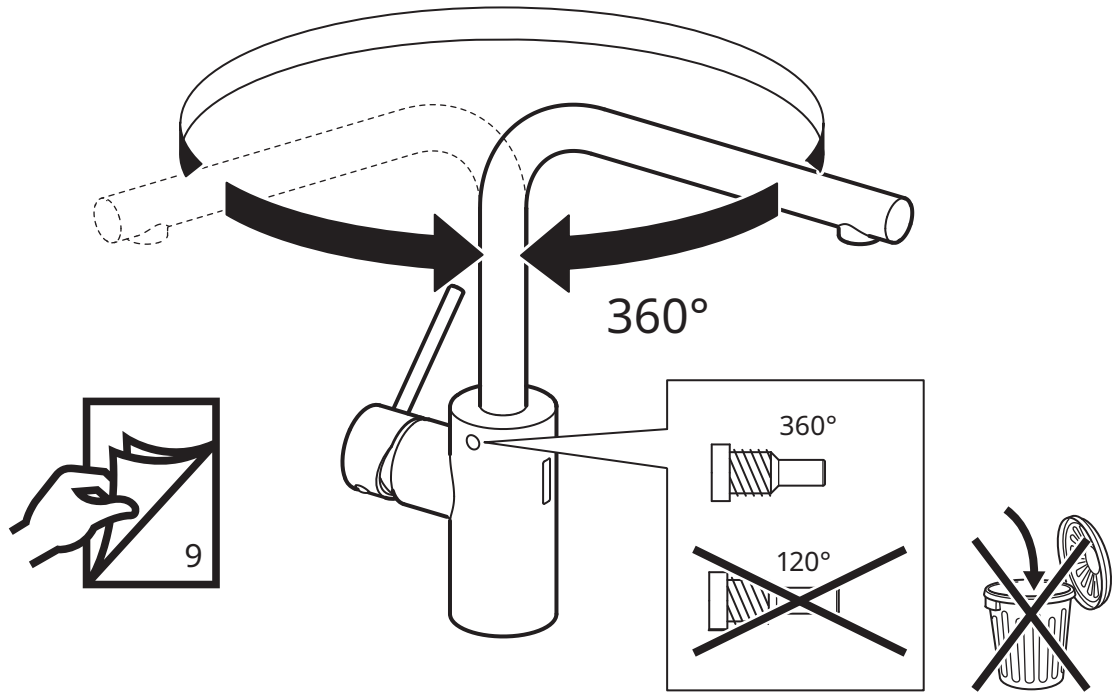

3

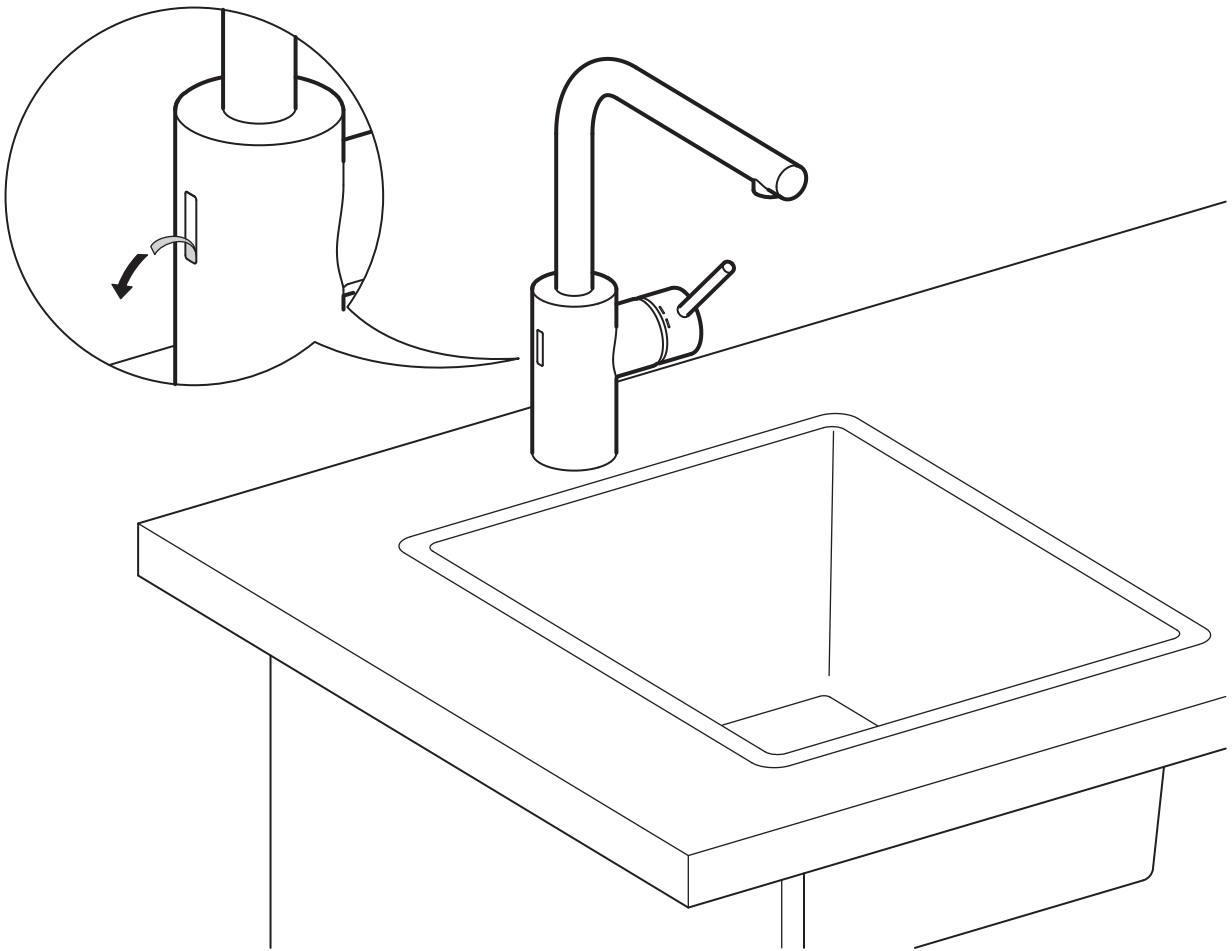

4

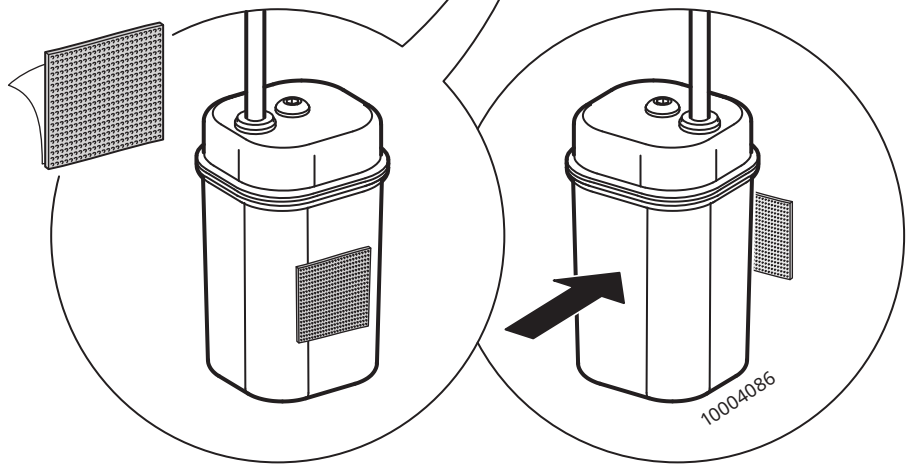
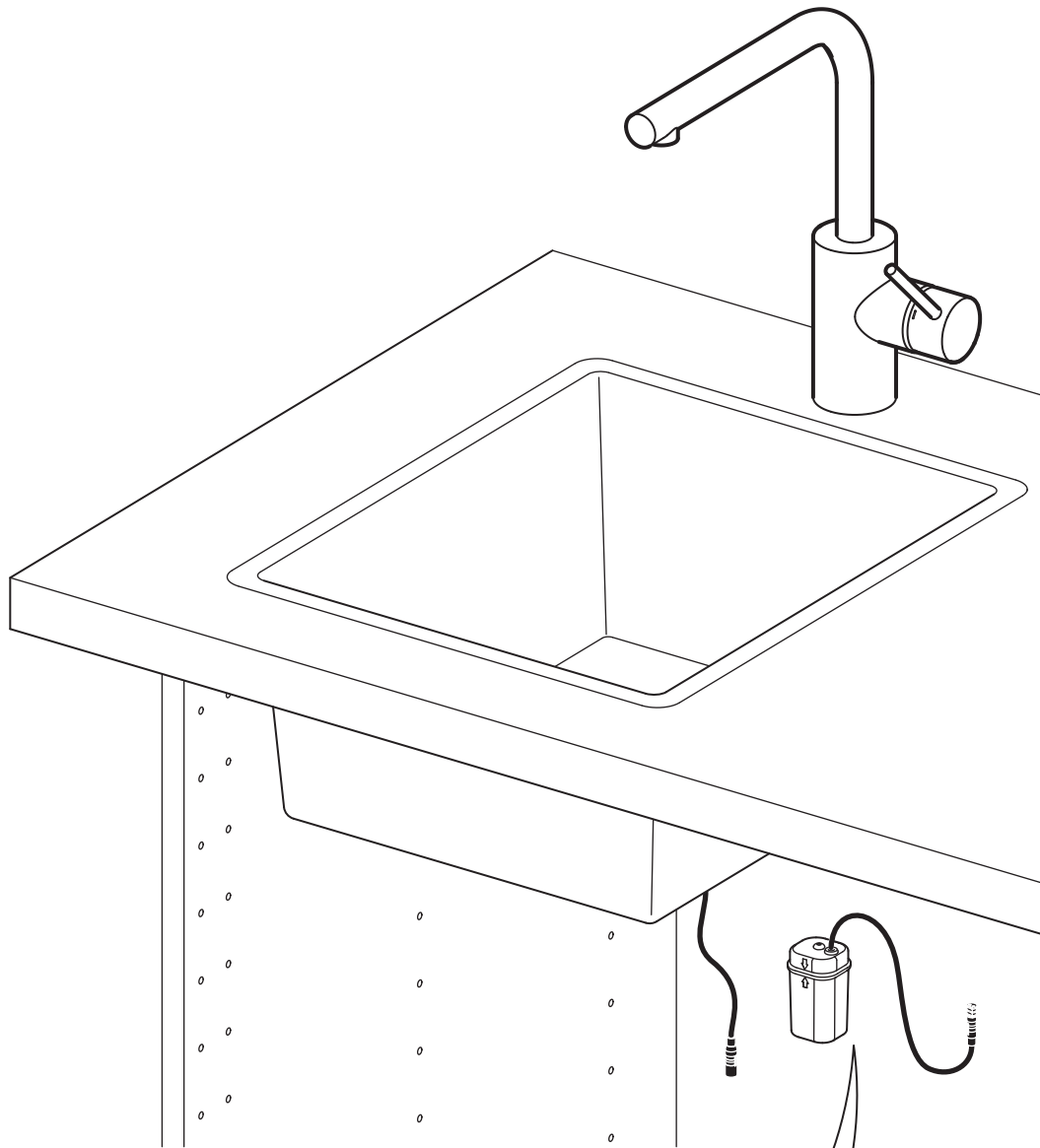

5

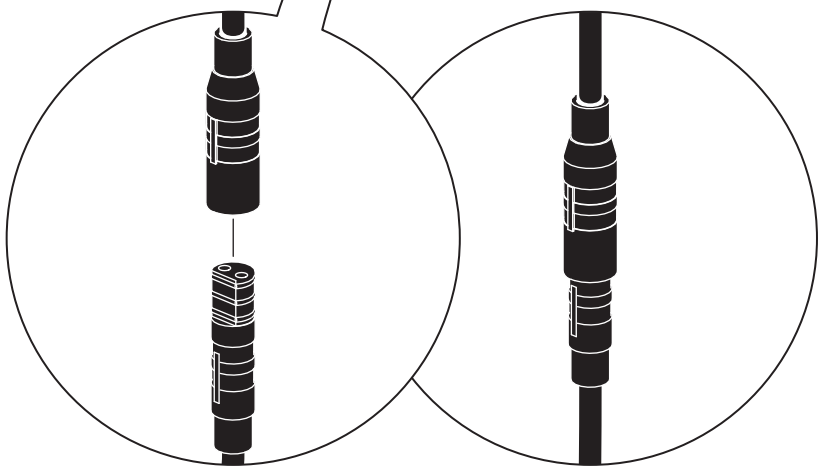
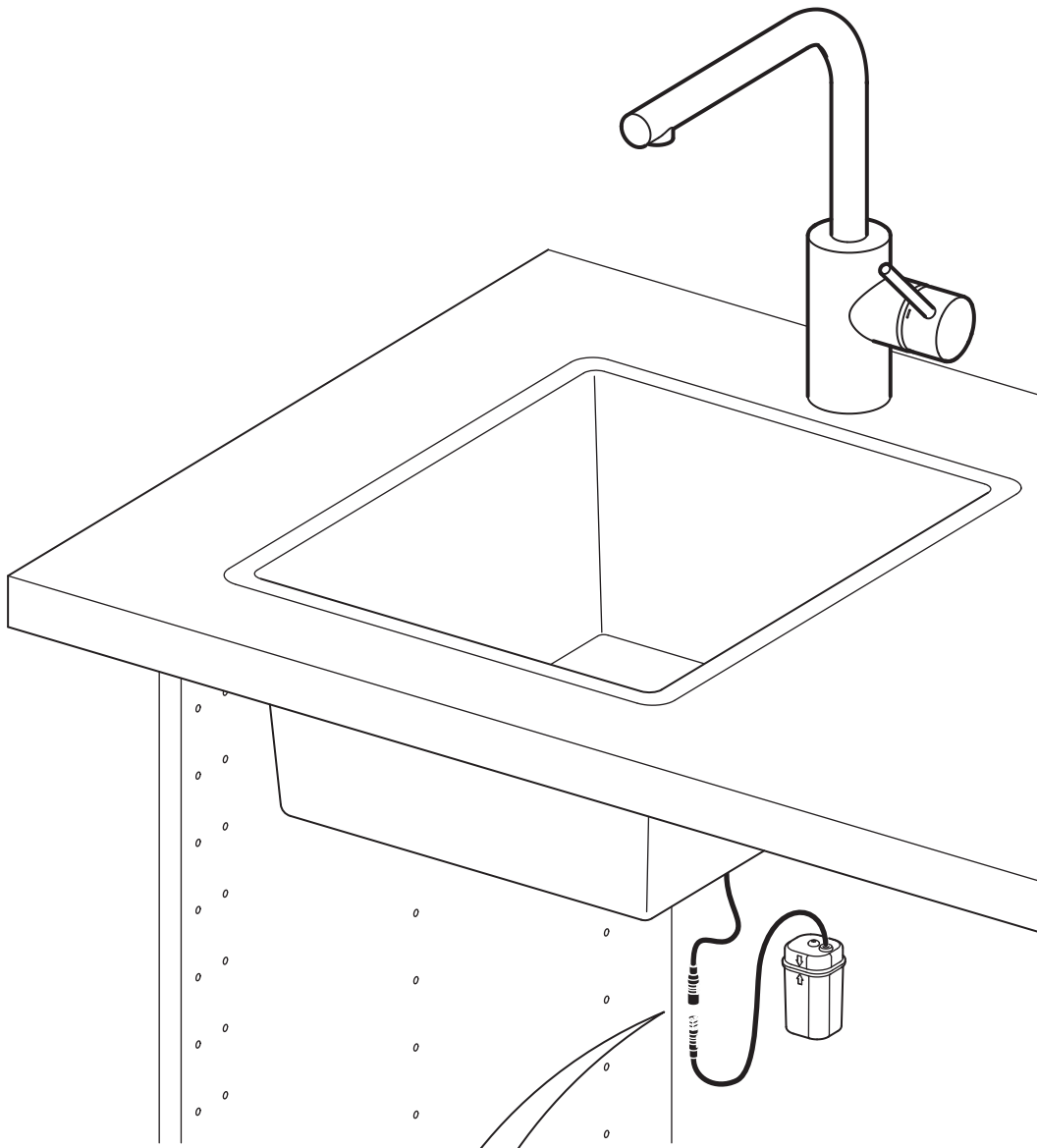

6

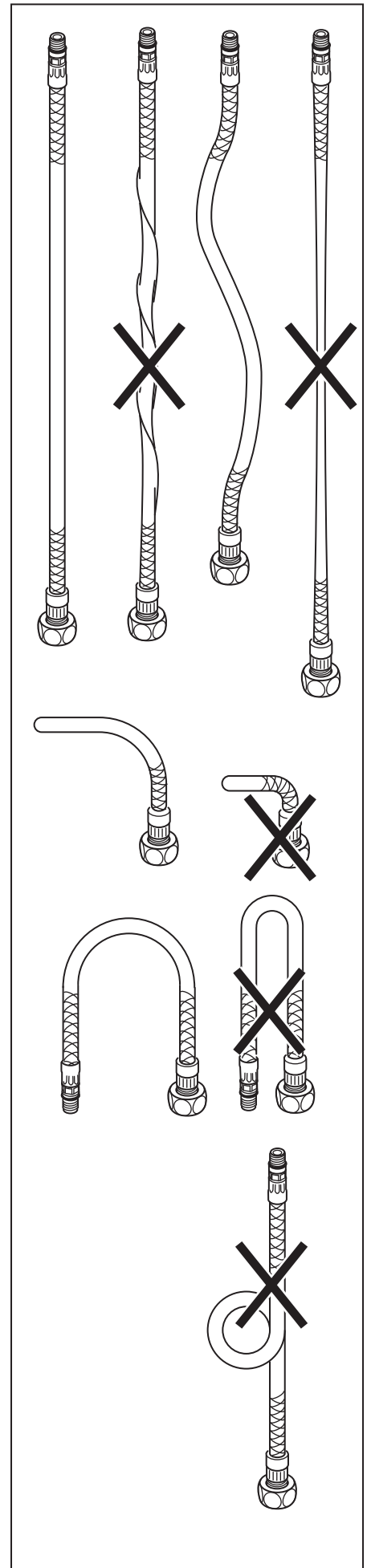
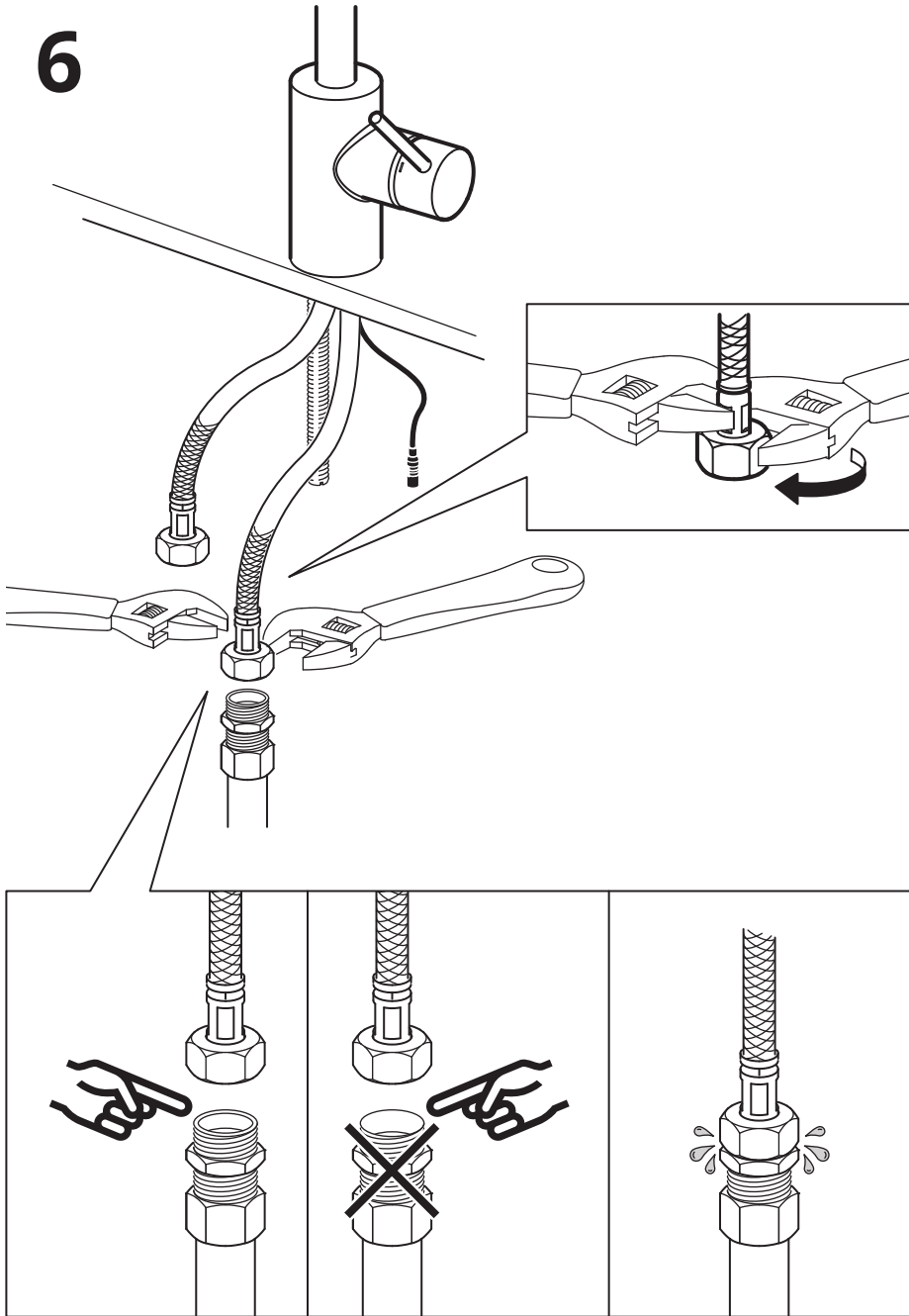

English

IMPORTANT! Do not tighten too hard: this can damage hoses/pipes and washers.

Français

ATTENTION ! Ne pas serrer trop fort : cela pourrait abîmer les flexibles/tuyaux et les joints.

Español

¡ATENCIÓN! No aprietes demasiado, ya que se pueden dañar las tuberías/conductos y las juntas.

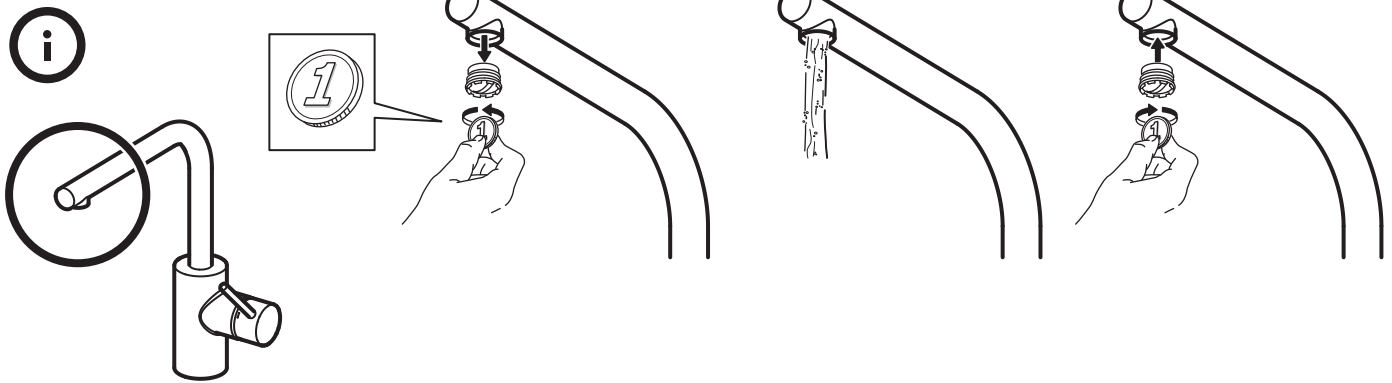
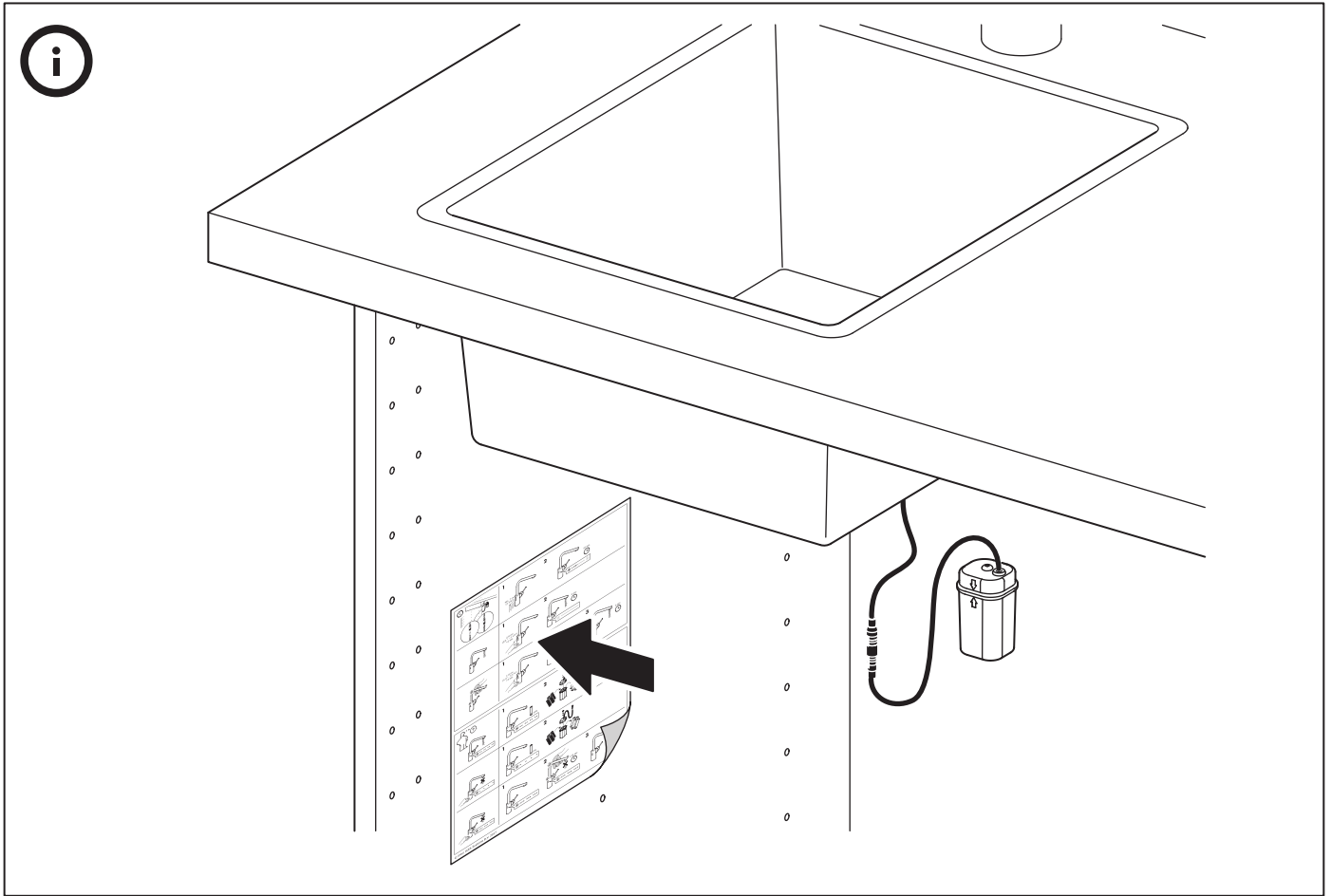

English

Before use: Unscrew the Aerator/Flow Guide with a coin and allow the water to run freely for a few minutes. Then screw the Aerator/Flow Guide back in place up to the stop DO NOT OVER TIGHTEN.

Français

Avant utilisation : dévisser l'aérateur/guide d'écoulement à l'aide d'une pièce de monnaie et laisser couler l'eau pendant quelques minutes. Puis remettre l'aérateur/guide d'écoulement en place et le visser. Attention à ne pas trop serrer.

Español

Antes de utilizarlo: desenrosca el aireador/guía de desagüe con ayuda de una moneda y deja correr el agua libremente durante unos minutos. A continuación enróscalo de nuevo. Comprueba que está bien apretado, pero NO DEMASIADO.

**English**

Check at regular intervals to make sure that the installation is not leaking.

Français

Vérifier à intervalles réguliers que l'installation ne fuit pas.

Español

Comprobar a intervalos regulares que la instalación no gotee.

